

Metric Precision Ball Screws

German-Engineered, Manufactured and Supported Ball Screws and Assemblies

Thomson Recirculating Ball Screws

Broad range of precision products providing a “just right” solution

Thomson has manufactured ball screws and nuts for more than 50 years in Europe. Thanks to our quality management and culture of continuous improvement, we can offer the highest levels of performance, quality and reliability. Our products are used in high-precision machines and some of the most demanding industrial applications.

Superior Precision

Thomson ball screws are manufactured using patented, German-engineered Precision Screw Forming Technology (PST), which provides an accuracy of 23 microns/300 mm as standard and 12 microns/300 mm upon request.

Standard and Custom Offerings

The materials used to manufacture ball screws are critical to their performance. Thomson has decades of experience working with a wide range of standard and non-standard materials. Our experts can recommend the materials or coatings best suited for your application.

Reliability and Consistent Performance

Thomson has a background in flight-critical aerospace and defense applications that uniquely positions us to provide the highest levels of quality across all of our ball screw products. Our engineering laboratory performs qualification testing for performance against applicable DIN and ISO standards as well as a wide variety of custom configurations.

Broad Range for Almost Any Application Needs

Our line of ball screws comes in a wide range of diameters and leads. Ball nuts are available in a variety of standard and non-standard configurations,

which can be pre-loaded upon request. Patented manufacturing processes and designs provide accuracy and repeatability at an economical price.

Our varied product range is bound to contain the right drive for virtually any linear motion task: from miniature screws for efficient medical devices to machine tool screws requiring ultra accuracy, high speed and structural stiffness.

Regardless of the technical challenge, Thomson can supply a ball screw to match the most demanding requirements for load, speed, stiffness, accuracy, and life.

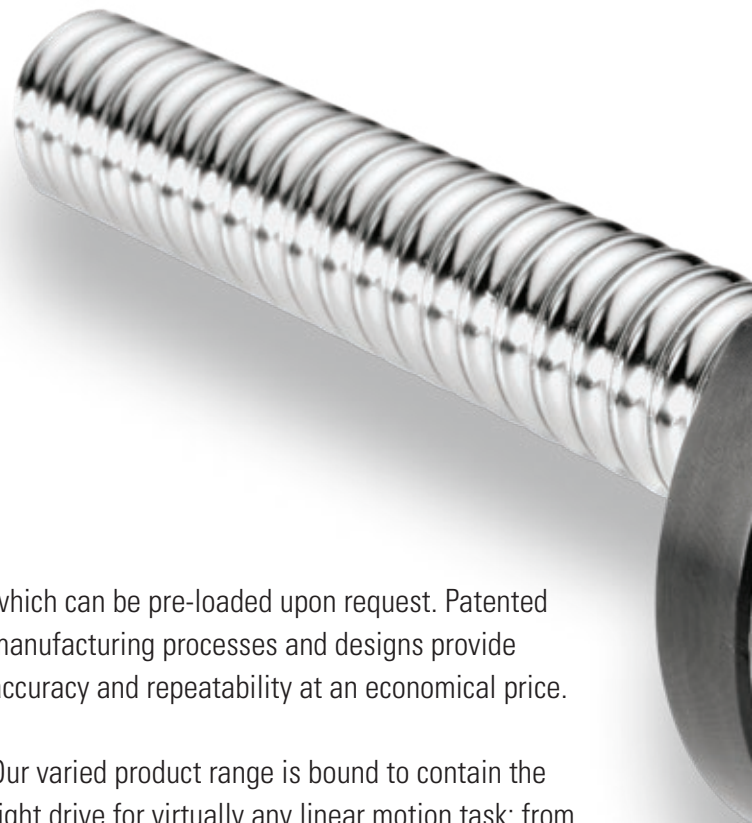

Application Support

Not all ball screws are alike. Differences in design, quality, materials, manufacturing and application support are all factors that affect their performance and extend their lives.

Thomson field sales and applications engineering personnel are skilled at evaluating your requirements and designing assemblies that fit your needs. They can also quickly and knowledgeably address application concerns and recommend solutions.

Consistent Quality and Delivery

A combination of advanced engineering and proprietary manufacturing processes consistently exceed performance, precision and life versus comparable ball screws.



Applications

With more than 50 years in the ball screw business, Thomson can help you find the best suitable solution for your heavy duty application.

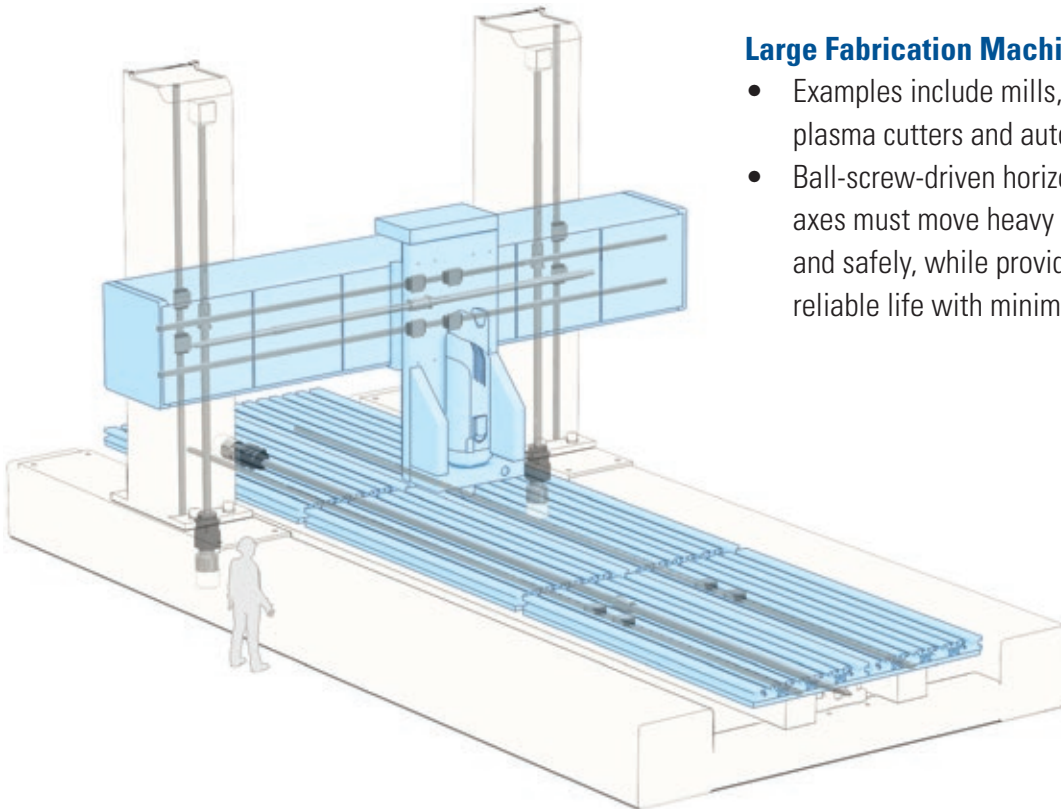

Large Fabrication Machines

- Examples include mills, water jets, plasma cutters and automatic welders.
- Ball-screw-driven horizontal and vertical axes must move heavy loads accurately and safely, while providing long and reliable life with minimum maintenance.

Injection Molding, Pressing and Metal Fabrication Machines

- Ball screws are necessary to handle high loads in a short stroke.
- Precision ball screws are required to control system accuracy and product tolerances.

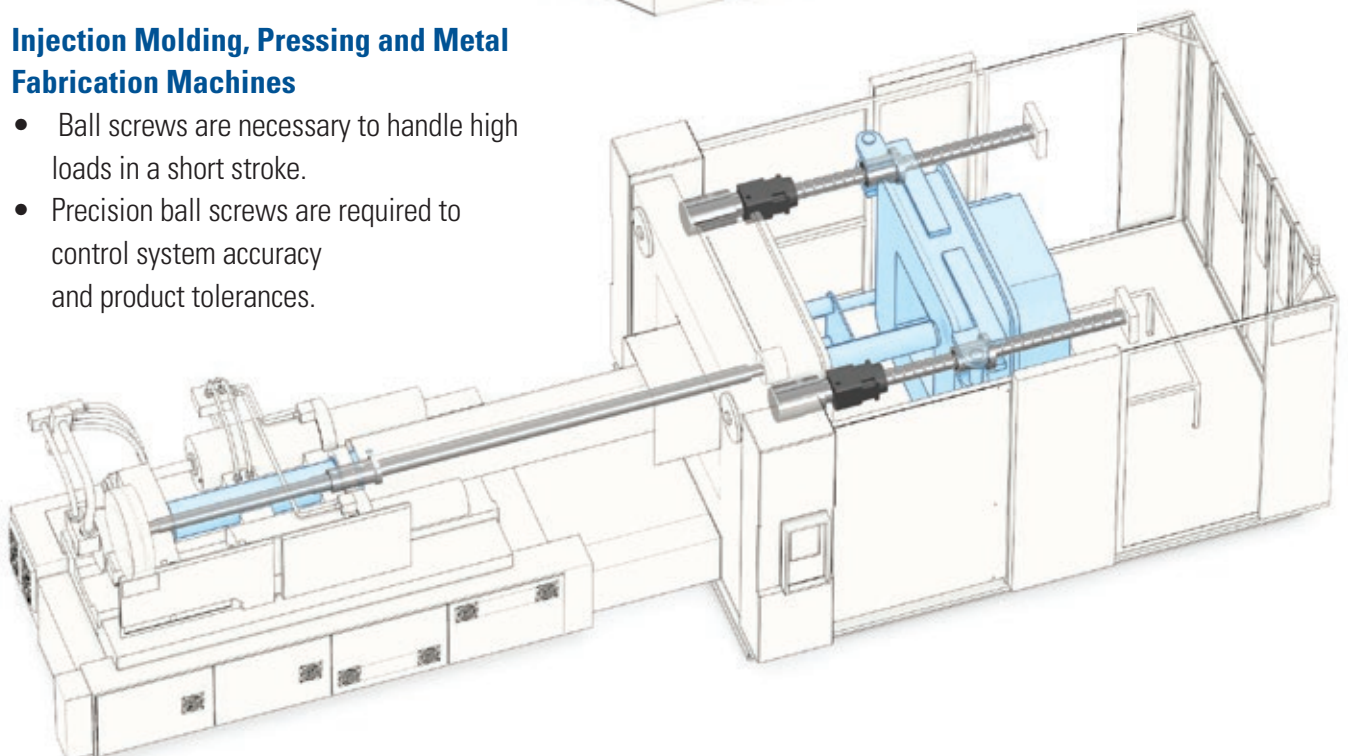

Robotics and Factory Automation

- No matter the size, stroke or load capacity of the ball screw needed, high accuracy as well as smooth and quiet travel are important.

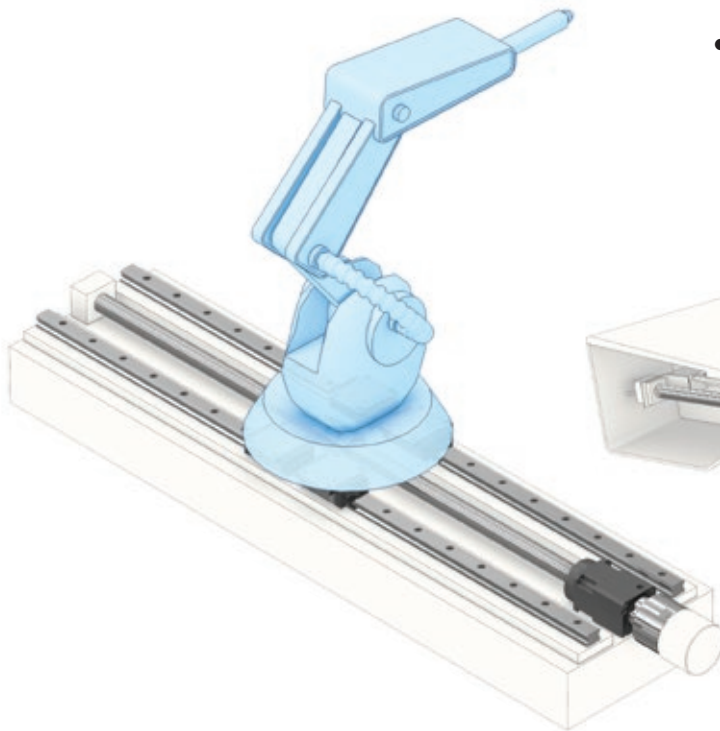

Aircraft and Vehicle Construction

- The familiar sound we hear during air travel is the reliable operation of ball screws driving flight-critical systems such as flaps, stabilizers, landing gear, hatches and fly-by-wire systems.
- Consistent quality control, engineering expertise and product excellence are critical for these applications.

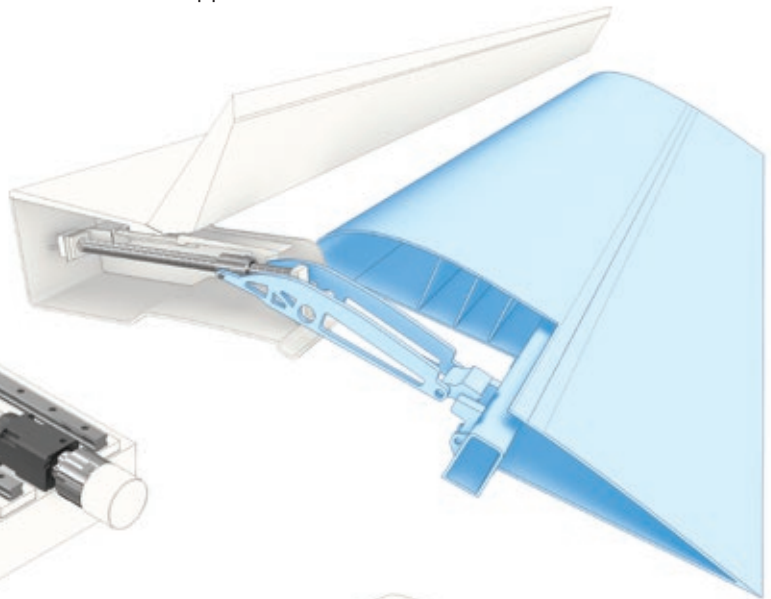

Medical Devices

- Examples include patient handling, ergonomics and critical system actuation.
- Smooth, quiet and precise drives are necessary for today's advanced medical imaging systems to provide accurate diagnostics for patients.

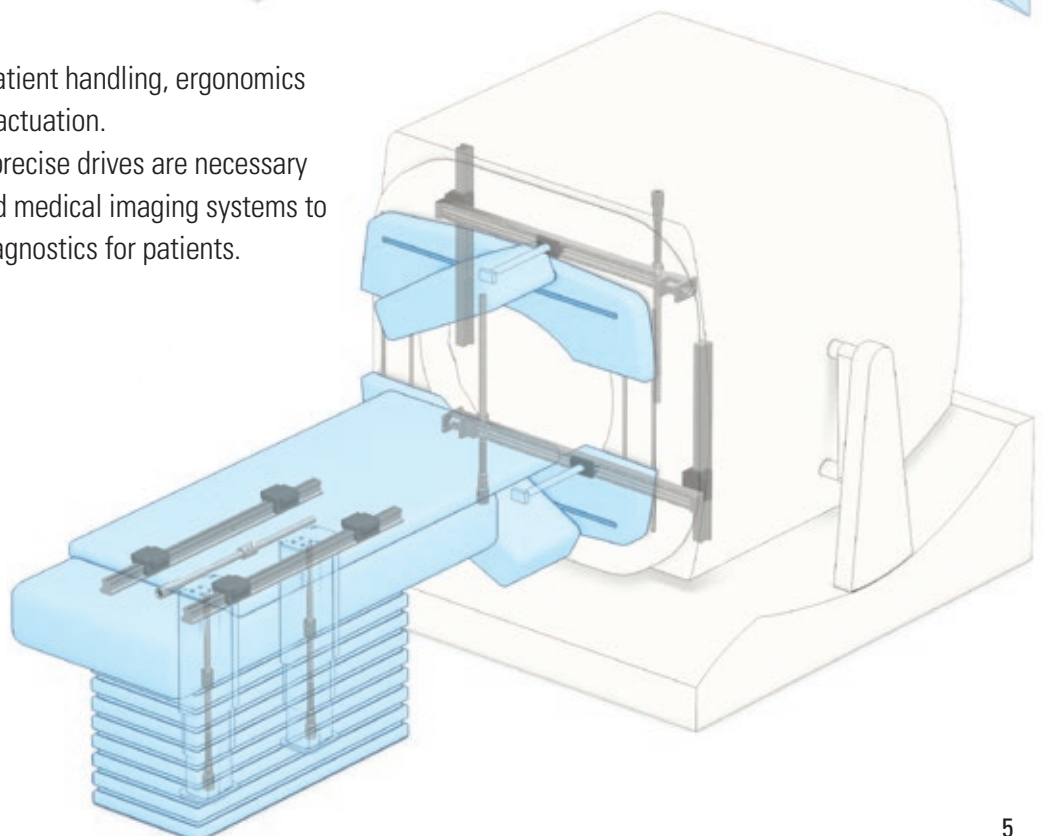

Ball Screws

Thomson precision-manufactured rolled, whirled and ground ball screws featuring a proprietary gothic arch thread profile designed to maximize load capacity and life.

Rolled Ball Screws

Rolled ball screw shafts are manufactured using our patented, German-engineered Precision Screw Forming Technology (PST) manufacturing process, which provides consistent accuracy of 23 µm/300 mm standard and 12 µm/300 mm upon request.

Rolled Ball Screw Assemblies

Thomson rolled ball screw assemblies are available in a wide range of diameters, leads and nut styles – all designed to provide quiet, smooth and efficient performance at an affordable price. They are ideal for machining centers, factory automation, packaging, injection molding, wood-working, water-jet cutting, electronic assembly and medical applications.

Whirled Ball Screws

Whirling is a hard turning process that provides an affordable alternative to grinding when applications require higher precision levels than is achievable by thread rolling. Whirled ball screw shafts are available in tolerance classes up to P3.

Ground Ball Screws

When your application requires the highest level of positional accuracy, Thomson can thread grind the ball form to ensure performance meets specification. Ground ball screw shafts are available in tolerance classes up to P1.



Ball Nuts

Thomson offers a wide breadth of ball nut configurations to seamlessly interface to the application. Most ball nuts have profiled wiper rings to reduce the escape of lubricant and prevent the ingress of dirt.

Ball Nut Mounting Alternatives

Thomson offers flanged ball nuts that are attached via a set of mounting holes or cylindrical nuts that have a keyway or external thread. Custom interfaces such as trunnions and nut housings are also available.

Ball Recirculation Systems

Thomson manufactures ball nuts with three different ball recirculation systems depending on the diameter and lead of the ball screw shaft in use.

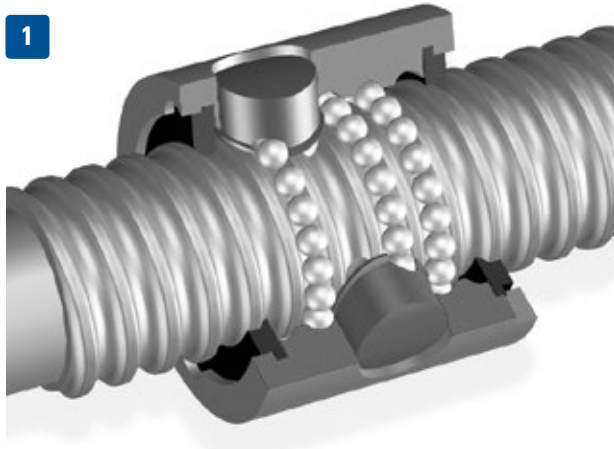

Single Return and Multi Liner

After each turn, the balls are lifted from the shaft raceway and set back by a single turn. Our return systems are made from glass-fiber reinforced plastic or steel to guarantee precise, gentle recirculation of the balls.

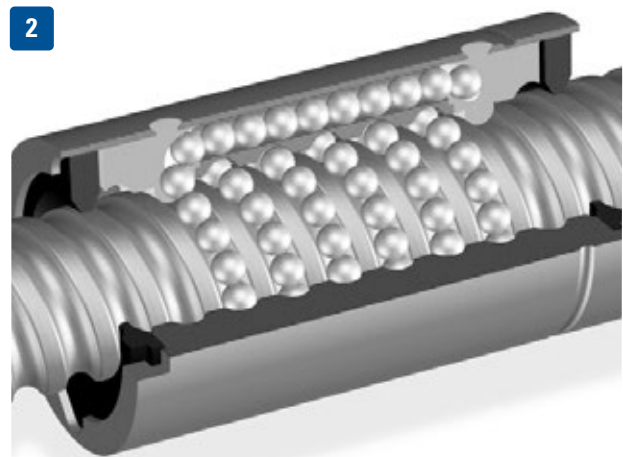

Channel Return

After several turns, the balls are returned either by a patented plastic recirculation system integrated into the nut or through channels also integrated into the nut using steel inserts.

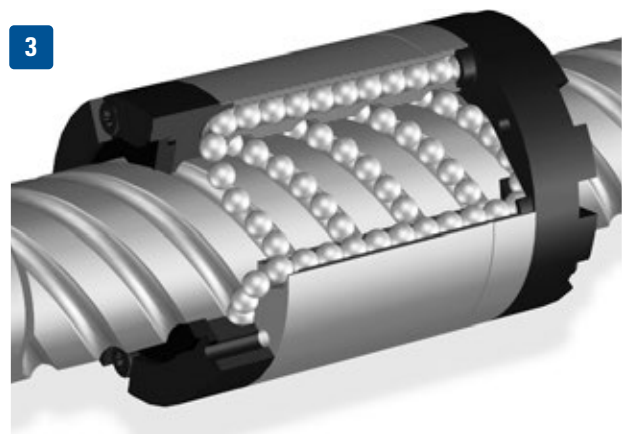

End-Cap Return

The balls are recirculated via two special end caps and return channels integrated into the nut.

Design Considerations and Customization

Selecting a ball screw assembly for a specific application is often about finding the smallest and most cost-effective solution that does the job. While it may seem like the same process every time, no two applications are alike, so it is important to consider the unique circumstances during the design phase.

This list shows the most common design considerations used to select a ball screw assembly:

- Compression or tension load
- Linear velocity
- Positional accuracy and repeatability
- Required life expectancy
- Mounting configuration
- Dimensional constraints
- Input power requirements
- Environmental conditions

At a minimum, the required load, linear velocity and positional accuracy should be known in order to calculate the diameter, lead and load capacity of the ball screw assembly. Individual ball screw components are then selected based on life, dimensional constraints, mounting configuration and environmental conditions.

Thomson also provides a range of accessories such as bearings, end supports and covers, making it easier to find a suitable solution for your application.

Customization and White Paper Designs

Thomson offers the most complete line of industrial ball screws but often applications require unique solutions that cannot be solved off-the-shelf. Our engineering expertise and capabilities to manufacture custom engineered solutions, including small batches, also addresses special application requirements.

We frequently develop and ship ball screw assemblies that have been altered in one or several ways such as:

- Custom sized screws and nuts
- Custom end machining
- Custom materials
- Custom surface treatment
- Custom assemblies
- Custom services



Support

At www.thomsonlinear.com/bs you can find help and information on how to select a ball screw solution for your motion task. If you don't find what you are looking for or need application engineering support, please contact Thomson customer support.

Sizing and Selection Process

Thomson application engineers convert your application questions and specifications into a final solution using an iterative process as illustrated below. Every piece of data is then engineered to filter down the solution set into an optimized product.



Ball Screw Size Chart

The Thomson ball screw range complies with DIN 69051 and ISO 3408. All ball nuts, both flanged and cylindrical, are available with connections complying with DIN specifications. Every shaft can be supplied with customized end journals, and upon request, customers can order screws with an annealed end for machining their own end journal.

Ball Screw Type vs Diameter and Lead Availability

		Ball Screw Diameter [mm]											
		12	16	20	25	32	40	50	63	80	100	125	160
Ball Screw Lead [mm]	4	●											
	5	●	●	●●	●●	●●	●●	●					
	10	●	●	●	●●	●●	●●	●●	●●	●●			
	12						●						
	15					●	●		●				
	20			●	●	●	●●	●●●	●●●	●●●	●●●	●●●	●●●
	25				●			●	●●	●●	●●	●●	●●
	30									●	●	●●	●●
	32					●							
	40					●	●				●	●	
	50			●	●								
	100							●●					

- Rolled
- Ground/Whirled
- Heavy Duty Ground/Whirled (load capacity up to 1500 kN dynamic / 6000 kN static)

How to Order

This ordering key provides an overview of available Thomson metric ball screws. To explore additional technical resources and options, contact Thomson customer support at www.thomsonlinear.com/contact.

Ordering Key Example

1	2	3	4	5	6	7	8	9	10	11	12	13	14	15	16	17													
KGT	-	D	-	20	05	-	T7	-	RH	-	K	105	-	1003	-	K	025	-	F	-	E	-	EE	-	R	-	0	-	1

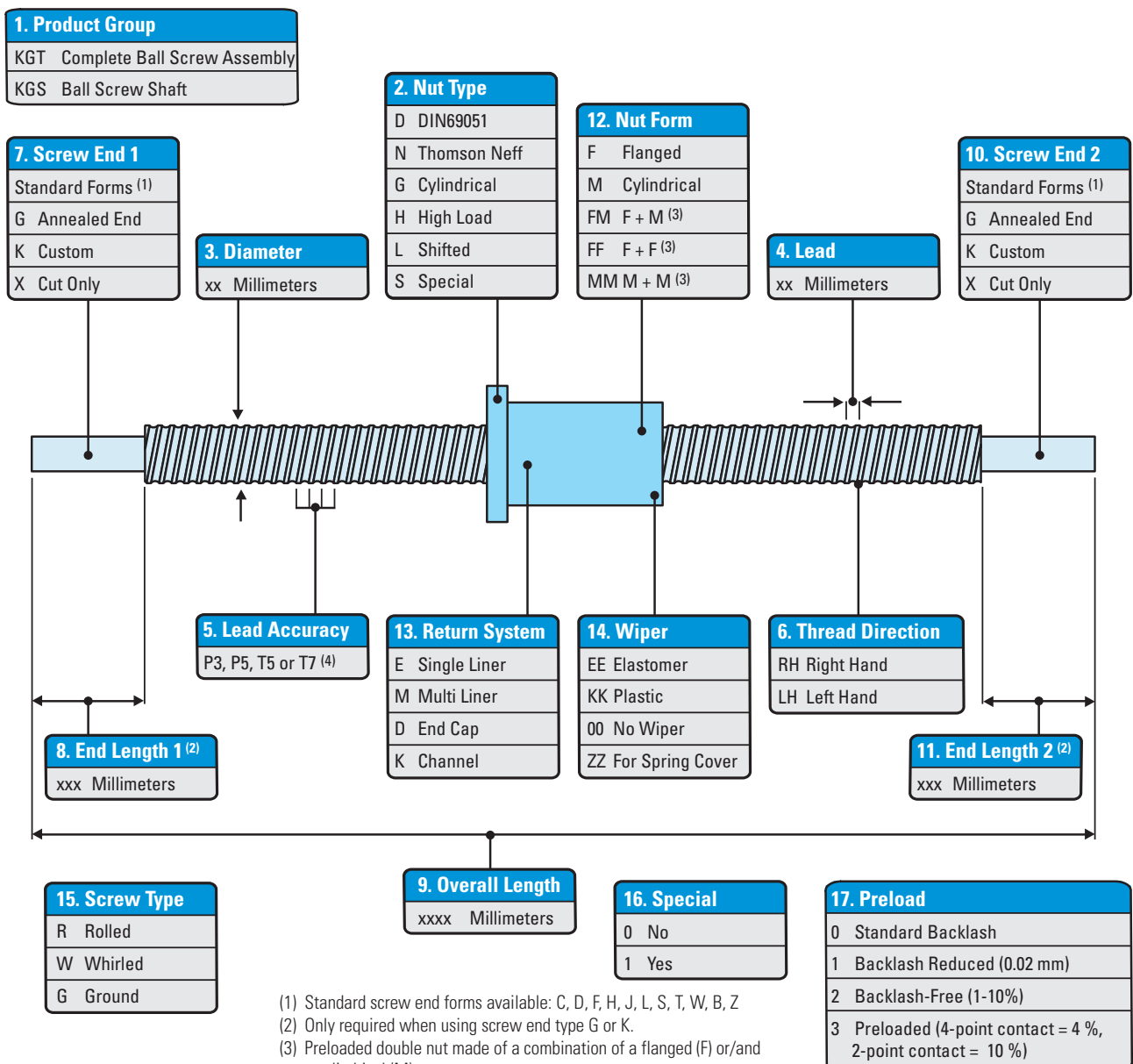

EUROPE

United Kingdom

Thomson
Caddsdwn Blue
Caddsdwn Business Park
Bideford EX39 3GB
Phone: +44 1271 334 500
E-mail: sales.europe@thomsonlinear.com

Germany

Thomson
Nürtinger Straße 70
72649 Wolfschlügen
Phone: +49 7022 504 403
Fax: +49 7022 504 405
E-mail: sales.europe@thomsonlinear.com

France

Thomson
Phone: +33 243 50 03 30
E-mail: sales.europe@thomsonlinear.com

Italy

Thomson
Via per Cinisello 95/97
20834 Nova Milanese (MB)
Phone: +39 0362 366406
Fax: +39 0362 276790
E-mail: sales.italy@thomsonlinear.com

Sweden

Thomson
Estridsväg 10
29109 Kristianstad
Phone: +46 44 590 2400
Fax: +46 44 590 2585
E-mail: sales.europe@thomsonlinear.com

USA, CANADA and MEXICO

Thomson
203A West Rock Road
Radford, VA 24141, USA
Phone: +1 540 633 3549
Fax: 1 540 633 0294
E-mail: thomson@thomsonlinear.com
Literature: literature.thomsonlinear.com

ASIA

Asia Pacific

Thomson
E-mail: sales.apac@thomsonlinear.com

China

Thomson
Rm 805, Scitech Tower
22 Jianguomen Wai Street
Beijing 100004
Phone: +86 400 606 1805
Fax: +86 10 6515 0263
E-mail: sales.china@thomsonlinear.com

India

Kollmorgen – Div. of Altra Industrial Motion
India Private Limited
Unit no. 304, Pride Gateway,
Opp. D-Mart,
Baner Road, Pune, 411045
Maharashtra
Phone: +91 20 67349500
E-mail: sales.india@kollmorgen.com

South Korea

Thomson
3033 ASEM Tower (Samsung-dong)
517 Yeongdong-daero
Gangnam-gu, Seoul, South Korea (06164)
Phone: + 82 2 6001 3223 & 3244
E-mail: sales.korea@thomsonlinear.com

SOUTH AMERICA

Brasil

Thomson
Av. João Paulo Ablas, 2970
Jardim da Glória - Cotia SP - CEP: 06711-250
Phone: +55 11 4615 6300
E-mail: sales.brasil@thomsonlinear.com

www.thomsonlinear.com

Metric_Ball_Screws_BRUK-0028-04 | 20221201 SK

Specifications are subject to change without notice. It is the responsibility of the product user to determine the suitability of this product for a specific application. All trademarks are the property of their respective owners.
© 2022 Thomson Industries, Inc.

 **THOMSON**[®]

Linear Motion. Optimized.[™]