

RAPID DELIVERY

Prototype
orders ship
in only

**1 to 2
weeks**

Metric Precision Ball Screws

German Engineering, DIN 69051 & North American Manufacturing

Combining the engineering and performance of high-quality, German ball screws with North American manufacturing and logistics.

Only 2% of all ball screws sold in North America are manufactured here, so you'll be able to take advantage of shorter lead times, reduced shipping costs, and enhanced communication with support and service.

Thomson metric ball screws provide the best in quality, performance and delivery at a competitive price.

German Engineered

- DIN 69051 compliant
- Patented Precision Screw Forming (PST) technology
- Smooth performance due to unique ball return systems

North American Manufactured

- Regionally stocked/machined/assembled product in Marengo, Illinois
- P5 accuracy screws standard
- Ground quality ball nuts

Metric Ball Nuts – Technical Specifications



Standard Lead Accuracy: $\pm 23 \mu\text{m} / 300 \text{mm}^{(1)}$

Internal Return Flanged Ball Nut and Screw

- Flexible solution for standard mounting
- Integral wiper and flange included as standard
- Available in three preload classes (Type Z1, Z2, Z3)
 - Z1 – light preload to 1-2%
 - Z2 – no preload, clearance held to max. indicated in table (standard unless specified)
 - Z3 – no preload, clearance held to max 0.05 mm

Technical Specifications

Nom. Diameter	Lead	Nut Form	Ball Nut P/N	Ball Screw P/N	Performance Data					Screw Specifications				
					Dynamic Load Capacity		Static Load Capacity		Max Axial Backlash	Major Diameter	Minor Diameter	Std Length	Max Length	Screw Weight
					[kN]	[lbs]	[kN]	[lbs]						
16	5	E	7106-448-061	195-9698	9.3	2091	13.1	2945	0.08	15.3	12.9	4000	6000	1.30
16	10	E	7106-448-062	195-9699	15.4	3462	26.5	5958	0.08	15.2	13.0	4000	6000	1.30
20	5	E	7107-448-063	195-9700	10.5	2361	16.6	3732	0.08	19.3	16.9	4000	6000	2.00
25	5	E	7110-448-064	195-9701	12.3	2765	22.5	5058	0.08	24.3	21.9	4000	6000	3.30
25	10	E	7110-448-065	195-9702	13.2	2968	25.3	5688	0.08	24.3	21.9	4000	6000	3.30
25	20	S	7110-448-066	195-9703	13.0	2923	23.3	5238	0.15	24.4	22.0	4000	6000	3.30
25	25	S	7110-448-067	195-9704	16.7	3754	32.2	7239	0.08	24.3	22.0	4000	6000	3.30
32	5	E	7112-448-069	195-9706	21.5	4834	49.3	11084	0.08	31.3	28.9	4000	6000	5.60
32	10	E	7112-448-070	195-9707	33.4	7509	54.5	12253	0.08	32.5	27.3	4000	6000	5.60
32	20	E	7112-448-071	195-9708	29.7	6677	59.8	13444	0.08	31.5	27.9	4000	6000	5.60
40	5	E	7115-448-073	195-9710	23.8	5351	63.1	14186	0.08	39.3	36.9	4000	6000	9.00
40	10	E	7115-448-074	195-9711	38.0	8543	69.1	15535	0.08	39.3	34.1	4000	6000	8.40
40	20	E	7115-448-075	195-9712	33.3	7487	76.1	17109	0.08	39.5	35.9	4000	6000	9.00
40	40	S	7115-448-076	195-9713	35.0	7869	101.9	22909	0.08	38.7	36.3	4000	6000	9.00
50	10	E	7120-448-077	195-9714	68.7	15445	155.8	35027	0.08	49.3	44.1	4000	6000	13.50

1. P3 accuracy class is $\pm 12 \mu\text{m} / 300 \text{mm}$ and is available upon request.

2. Dimension does not comply with DIN 69051.

3. Round flange.

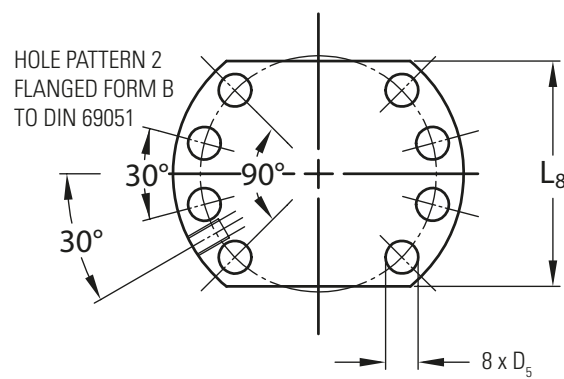
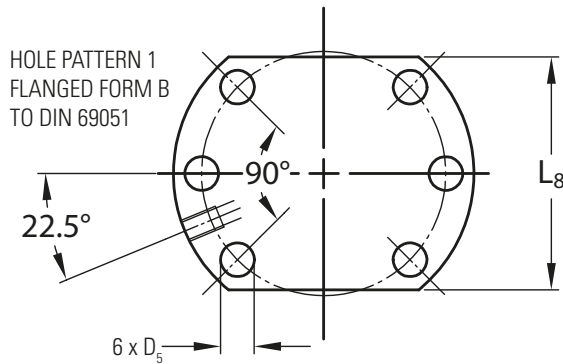
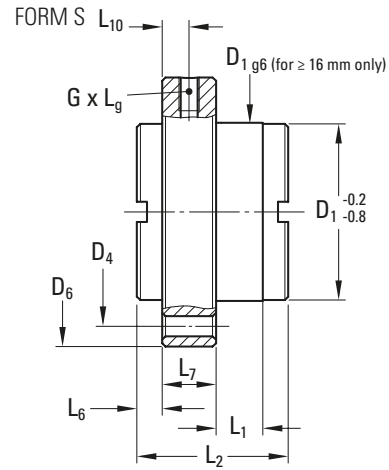
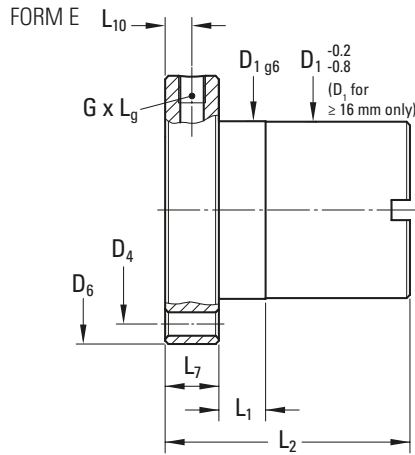

Technical Specifications

	Nom. Diameter	Lead	Hole Pattern	Nut Specifications													Lube Hole (G)	No. of Circuits	Ball Diameter
				D1 g6	D4	D5	D6	L1	L2	L6	L7	L8	L10						
	[mm]	[mm]		[mm]	[mm]	[mm]	[mm]	[mm]	[mm]	[mm]	[mm]	[mm]	[mm]	[mm]			[mm]		
	16	5	1	28	38	6	48	10	42	-	10	40	5	M6x1	3	3.500			
	16	10	1	28	38	6	48	10	55	-	10	40	5	M6x1	6	3.000			
	20	5	1	36	47	7	58	10	42	-	10	44	5	M6x1	3	3.500			
	25	5	1	40	51	7	62	10	42	-	10	48	5	M6x1	3	3.500			
	25	10	1	40	51	7	62	16	55	-	10	48	5	M6x1	3	3.500			
	25	20	1	40	51	7	62	4	35	10.5	10	48	5	M6x1	4	3.500			
	25	25	1	40	51	7	62	9	35	8	10	N/A ^[3]	5	M6x1	5	3.500			
	32	5	1	50	65	9	80	10	55	-	12	62	6	M6x1	5	3.500			
	32	10	1	53 ^[2]	65	9	80	16	69	-	12	62	6	M8x1	3	7.140			
	32	20	1	53 ^[2]	65	9	80	16	80	-	12	62	6	M6x1	4	5.000			
	40	5	2	63	78	9	93	10	57	-	14	70	7	M6x1	5	3.500			
	40	10	2	63	78	9	93	16	71	-	14	70	7	M8x1	3	7.140			
	40	20	2	63	78	9	93	16	80	-	14	70	7	M8x1	4	5.000			
	40	40	2	63	78	9	93	16	85	7.5	14	N/A ^[3]	7	M8x1	8	3.500			
	50	10	2	75	93	11	110	16	95	-	16	85	8	M8x1	5	7.140			

How to Order

This ordering key provides a quick overview of the metric ball screw assemblies available. To explore additional technical resources and options, contact Thomson customer support.

Ordering Key												
1	2	3	4	5	6	7	8	9	10	11	12	13
RM	25	10	FD	Z2-	271.5	L	W-	BK	S	K	X	
1. Nut Configuration RM = Metric 2. Nominal thread diameter 10 = 10 mm 12 = 12 mm 16 = 16 mm 20 = 20 mm 25 = 25 mm 32 = 32 mm 40 = 40 mm 50 = 50 mm 63 = 63 mm 80 = 80 mm 3. Thread lead 02 = 2 mm 03 = 3 mm 04 = 4 mm 05 = 5 mm 10 = 10 mm 20 = 20 mm 25 = 25 mm 40 = 40 mm	4. Nut style T = Threaded internal ball return (TSI) R = Cylindrical internal ball return (RSI) FD = Flanged internal ball return (FSI) FK = Flanged (DIN 69051), metal ball return FN = Flanged, polymer ball return MD = Flanged (DIN 69051), polymer ball return MG = Threaded, metal ball return 5. Nut assembly condition Z1 = Light preload (1-2%) Z2 = Standard backlash Z3 = Backlash reduced (0.05 mm max.) 6. Threaded length xxx.x = Length (mm) 7. Nut orientation R = Nut faces right end L = Nut faces left end X = Nut ships on arbor 8. Wipers X = No wipers W = Polymer wipers (standard)	9. Left end configuration X = Cut to length K = Machine to print with drive BK = Base mount with drive BK1 = Base mount without drive BF = Floating base mount with drive BK1 = Floating base mount without drive FK = Flange mount with drive FK1 = Flange mount without drive FF = Floating flange mount with drive FF1 = Floating flange mount without drive QK = Base mount with drive QK1 = Base mount without drive QF = Floating base mount with drive QK1 = Floating base mount without drive WK = Heavy duty flange with drive WK1 = Heavy duty flange without drive MK = Motor mount with drive 10. Left screw support configuration X = No support (machined only) S = Support installed on machined surface	11. Right end configuration X = Cut to length K = Machine to print with drive BK = Base mount with drive BK1 = Base mount without drive BF = Floating base mount with drive BK1 = Floating base mount without drive FK = Flange mount with drive FK1 = Flange mount without drive FF = Floating flange mount with drive FF1 = Floating flange mount without drive QK = Base mount with drive QK1 = Base mount without drive QF = Floating base mount with drive QK1 = Floating base mount without drive WK = Heavy duty flange with drive WK1 = Heavy duty flange without drive MK = Motor mount with drive 12. Right screw support configuration X = No support (machined only) S = Support installed on machined surface 13. Custom Modifier blank = Standard M = Custom									
Code Example: RM2510FDZ2-271.5LW-BKSKX This describes a standard lashed Ø25 x 10 mm FSI ball screw assembly that is 271.5 mm in threaded length with a BK bearing support on the left side with drive extension, BK end bearing support without drive on the right side. The flange faces the left side (the side with the drive extension). NOTE: Not all bearing supports are available in all sizes. See catalog or contact customer support for available combinations.												

Express Prototypes, Less Lead Time

Prices and lead times are generally higher with other products as 98% of rolled metric ball screws are manufactured outside of North America.

Thomson provides expert application support and the ability to rapidly prototype designs by combining North American manufacturing of metric products with the engineering support of a trusted brand.

USA, CANADA and MEXICO

Thomson Customer Support
 203A West Rock Road
 Radford, VA 24141, USA
 Phone: 1-540-633-3549
 Fax: 1-540-633-0294
 E-mail: thomson@thomsonlinear.com
 Literature: literature.thomsonlinear.com

Don't pay extra to wait.

Order your Thomson prototype with delivery from our North American facility in Marengo:

	Standard Lead Time	Express Lead Time (Qualified Prototypes)
Components	2 - 3 days	1 day
Machined Assemblies	2 - 4 weeks	1 - 2 weeks

Thomson Marengo, IL USA

ISO 9001 certified, 88,000 sq. ft. facility manufacturing Linear Actuators, Ball Screws, Linear Bearings & Shafting, and Step Motors. Founded in 1967, currently with 220 employees.

www.thomsonlinear.com

Metric_Precision_Rolled_Ball_Screws_BREN-0022-02 | 20200220SK
 Errors and technical alterations reserved. It is the responsibility of the product user to determine the suitability of this product for a specific application. All trademarks property of their respective owners. ©2020 Thomson Industries, Inc.

