

MovoZ Z3

Installation and service manual

www.thomsonlinear.com



Table of Contents

Section 1	Introduction	3
Section 2	Type designation system	4
Section 3	Installation	5
3.1	Main features	5
3.2	Suspension instructions	6
3.3	Connection of load	6
3.4	Brake installation.....	6
3.5	Motor installation.....	6
3.6	Operation limits and end position indicators.....	7
3.7	Installation of motor bracket p/n D800 264 and gear BS40 on unit MGZ3K3220.....	8
3.8	Suspension of MovoZ Z3 with suspension frame p/n D800 250	8
3.9	Installation of service lock p/n D800 072.....	9
3.10	Adjustment of magnet sensor	9
Section 4	Service and maintenance	10
4.1	General maintenance instructions.....	10
4.2	Lubrication	10
Section 5	Technical data	11
5.1	Technical data	11
5.2	Maximum permissible speed.....	11

Section 1 Introduction

MovoZ Z3 is a telescopic actuator used in lifting applications that consists of three extruded aluminium profiles which is run in and out of each other with the aid of a ball screw. Slide bushings are mounted between the profiles. A motor with a brake or a motor and a separate brake is mounted in the upper end of the unit while the load is installed in the plate in the lower end of the unit.

Do not hesitate to contact Tollo Linear if you have any questions regarding installation or service. State the manufacturing number and the type designation of the unit, see point 3.1, in such case.

Important!

- Read through this manual before beginning the installation or servicing and follow all applicable directions in order to ensure a safe and proper job.
- In order to ensure a long life expectancy and reliable functionality, MovoZ Z3 must be serviced according to the directions found in this manual. Spare parts should be by the same manufacturer and of the same type as the original or be among those approved in writing by Tollo Linear. Never use parts which work improperly or seems damaged.
- The system or machine part of which MovoZ Z3 is a component must not be used before it is in compliance with the EU's Machinery Directive in those instances where it is to be used within the EEC area.
- If possible, never work with power, compressed air or hydraulics turned on. If the work must be performed with some of these turned on, another person must be positioned so that the power, compressed air or hydraulics can be turned off in the event of any mishap.

Section 2 Type designation system

M	G	Z3	K	25	10	9	-
Metric.....M	Slide bushings.....G	Profile size.....Z3	Ball screw + ball nut.....K	Type of ball screw, diameter / lead / tolerance class 25 mm / 10 mm / T9.....25.....10.....9 25 mm / 25 mm / T9.....25.....25.....9 32 mm / 20 mm / T7.....32.....20.....7			Hyphen.....-	Lmin. (min. retracted length in cm).....000 – 999	
							Lmax. (max. extended length in cm).....000 – 999		

Table 1: Type designations

Section 3 Installation

3.1 Main features

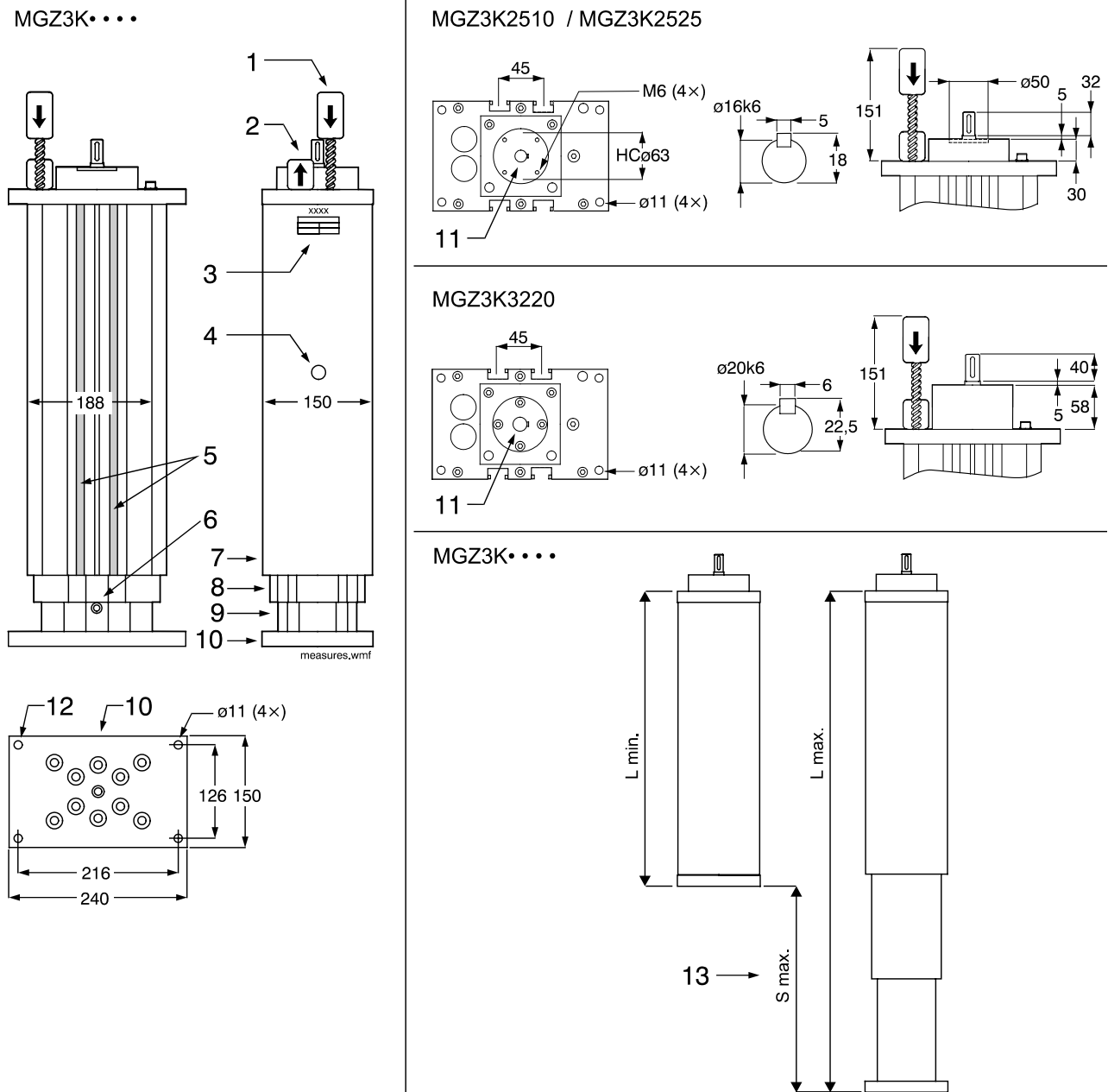

Figure 1: Main features

- | | | |
|---------------------------------------|--------------------------|---------------------------|
| 1. End position indicator "extended" | 6. Hole for service lock | 10. Load attachment plate |
| 2. End position indicator "retracted" | 7. Outer profile | 11. Drive shaft |
| 3. Manufacturing number / type plate | 8. Middle profile | 12. Load attachment holes |
| 4. Lubrication hole | 9. Inner profile | 13. Also see point 3.6. |
| 5. T-slots | | |

3.2 Suspension instructions

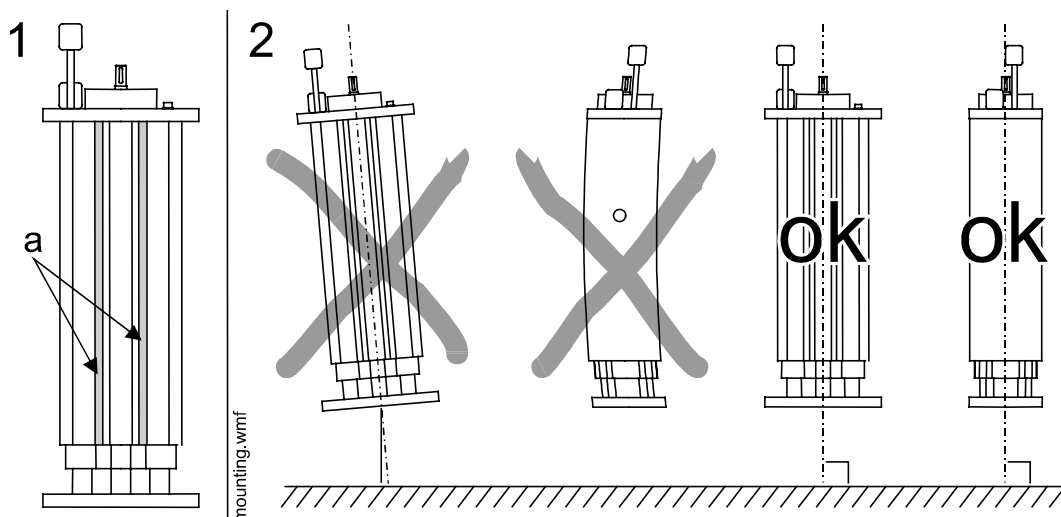

Figure 2: Suspension instructions

1. MovoZ Z3 must be suspended in the T-slots (a).
2. MovoZ Z3 must be suspended vertically and the outer profile may not be bent or twisted by any forces.

3.3 Connection of load

Connect the load to the load attachment plate, see point 3.1. Do not exceed the max. permissible load or the max. permissible load torque. Always try to mount the load in the centre of the unit in order to minimise the load torque thus increasing the life of the unit.

3.4 Brake installation

Important !

As MovoZ Z3 is not self-braking the load attachment plate and the load immediately will fall down if the driving force is disconnected. This means that MovoZ Z3 must be equipped with an electrically released brake that can hold the load. This brake can be integrated in the motor or be mounted separately,

3.5 Motor installation

On MovoZ Z3 units of type MGZ3K2510 and MGZ3K2525 the gear box or the intermediate flange for the motor is installed directly to the holes around the drive shaft. On units of type MGZ3K3220 a floating suspension method must be used which demands the use of a torque absorbing bracket in which the gear box or the intermediate flange can be installed so that no side torque is transmitted to the drive shaft. Such motor bracket, suitable for gearboxes of type BS40, is available from Tollo Linear. Also see point 3.7.

3.6 Operation limits and end position indicators

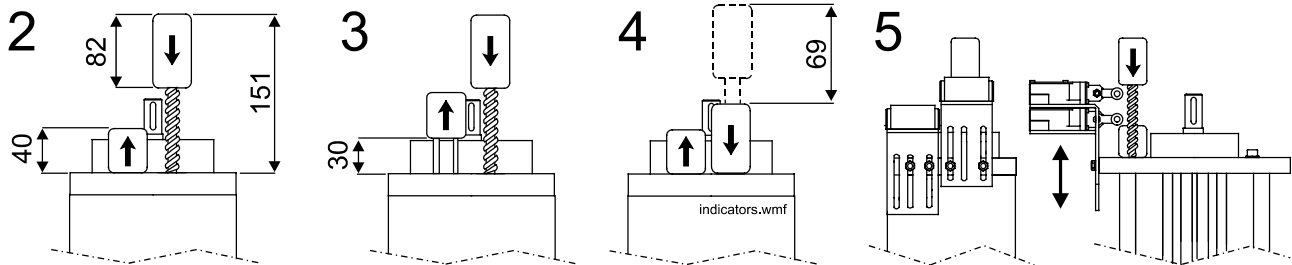
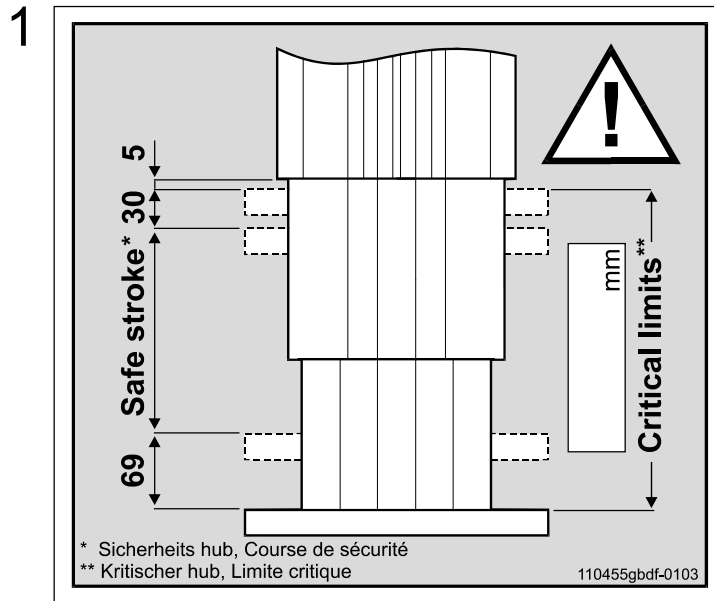

Figure 3: Operation limits

1. The recommended operation stroke is “Safe stroke”. If the unit is run outside of “Critical limits” the unit will collide with its mechanical end positions and become damaged. Note! Keep in mind that the length of the distance to stop ultimately depends on the speed and the deceleration the drive system is set to.
2. Normal positions of the end position indicators = the unit is within the “Safe stroke”. The end position indicators can be used together with limit switches to stop the unit if it should drive pass the recommended operation stroke (Safe stroke).
3. Position of the end position indicator “retracted” when the unit is fully retracted (in position L min.), also see point 3.1.
4. Position of the end position indicator “extended” when the unit is fully extended (in position L max.).
5. Limit switch brackets for the end position indicators, p/n D800 042. Suitable limit switches: Telemecanique XCK-M115.

3.7 Installation of motor bracket p/n D800 264 and gear BS40 on unit MGZ3K3220

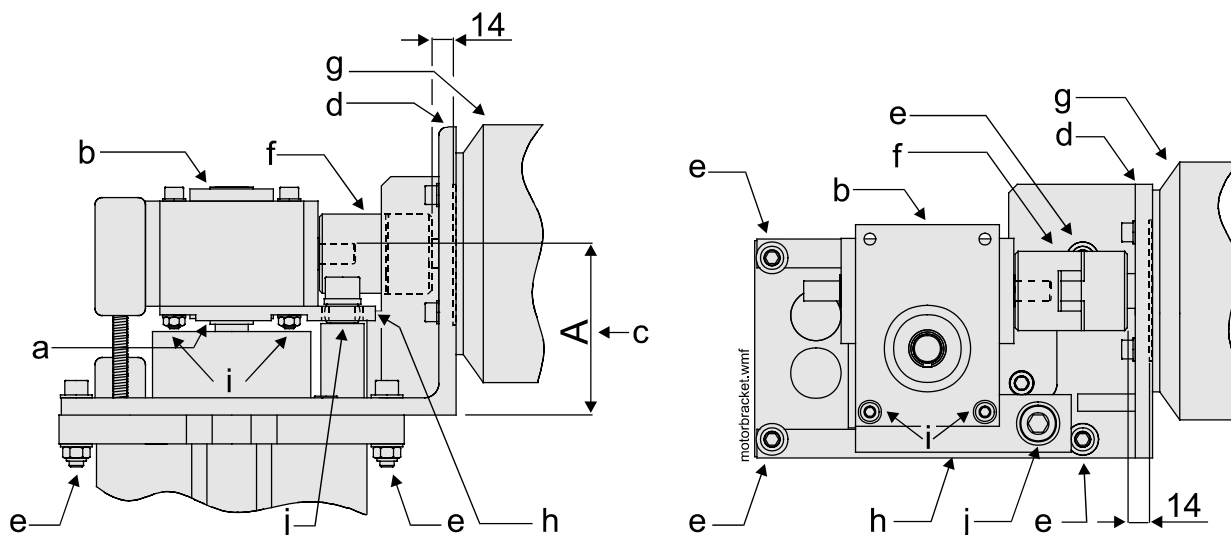

Figure 4: Installation of motor bracket

1. Mount the spacer washer (a) on the drive shaft of the unit and then place the gearbox (b) on the drive shaft.
2. Measure the distance (c) between the top of the upper plate and the top of the input shaft of the gearbox (distance A). Reduce the distance A with 118,3 mm = final value.
3. Place shims at the attachment holes on the upper plate of the unit corresponding to the final value and then attach the motor bracket (d) to the plate using the four screws (e). Do not tighten the screws fully.
4. Fit the coupling (f) to the shaft of the motor and the gearbox. Check so that the coupling on the motor shaft is positioned 14 mm from the motor.
5. Attach the motor (g) to the motor bracket (d).
6. Tighten the screws of the motor bracket (e).
7. Mount the torque bar (h) to the gear box with the aid of the two screws (i). Do not tighten the screws fully.
8. Place the link bearing (j) in the torque bar and bolt it to the motor bracket.
9. Tighten the screws (i) between the gearbox and the torque bar.
10. Fit the protective cover (not shown) over the coupling.

3.8 Suspension of MovoZ Z3 with suspension frame p/n D800 250

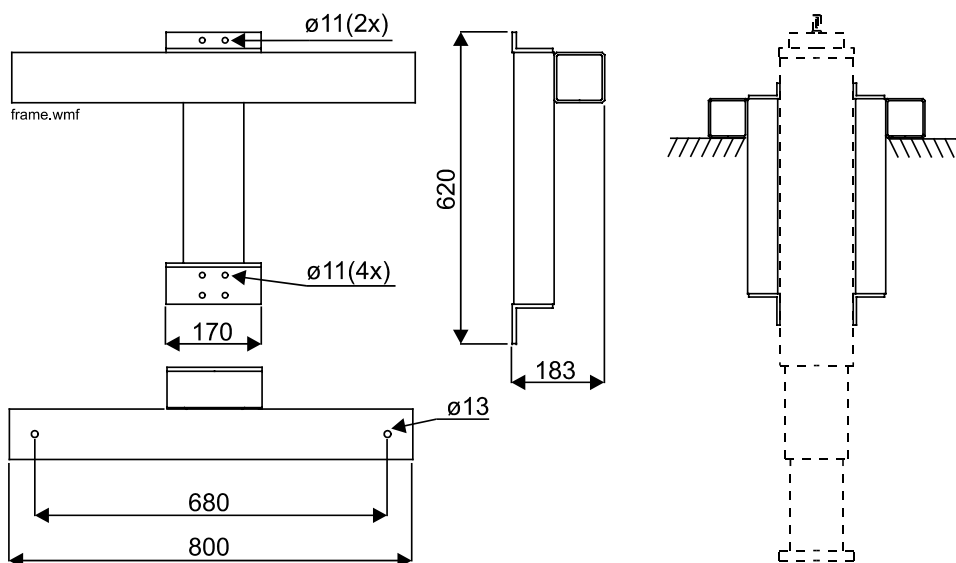

Figure 5: Suspension frame

3.9 Installation of service lock p/n D800 072

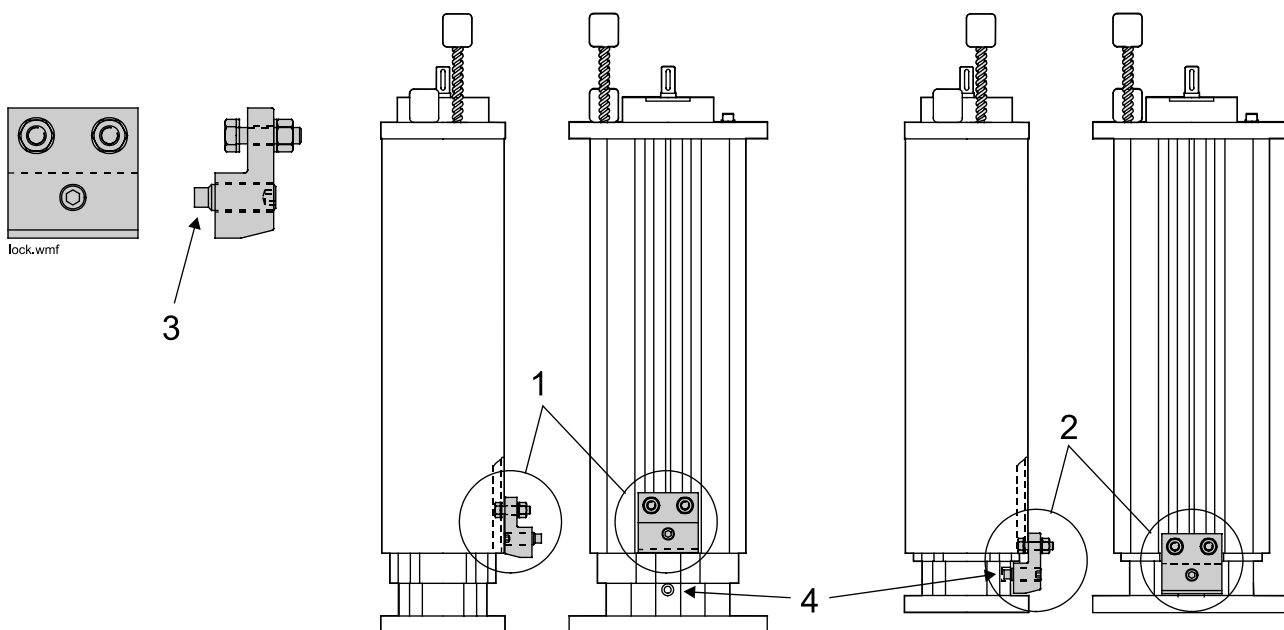
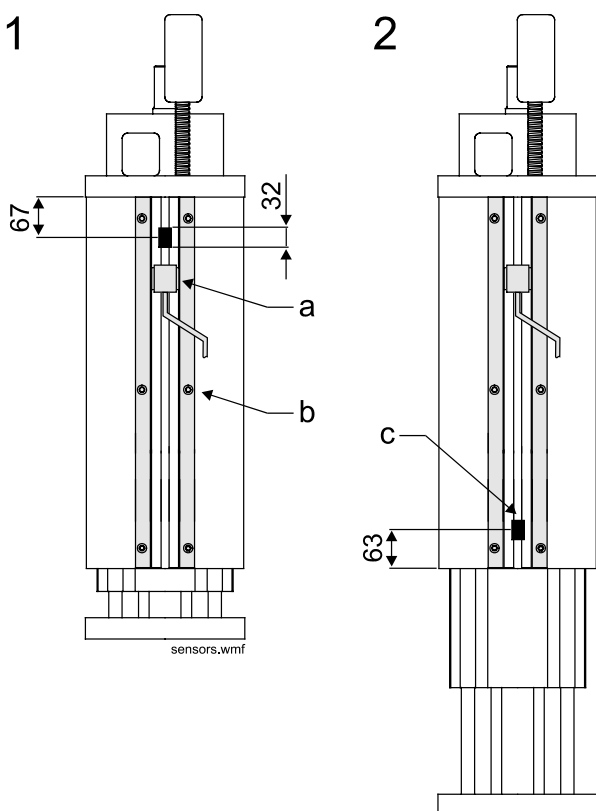

Figure 6: Service lock

The service lock is used to lock the profiles in connection to service when the brake needs to be detached. When the lock is not being used it is mounted with the flat side against the profile (1) with the aid of the T-slots in the profile. When it is used the lock is turned around (2) and mounted so that the lock pin (3) can be screwed in to the lock hole (4) and thereby lock all profiles.

3.10 Adjustment of magnet sensor



The magnet sensor is attached to the unit by means of the sensor rails (p/n D800 223). How the rails are installed is described in the instruction supplied with the sensors.

To be able to adjust a sensor (a) the fixing screws (b) of the rails must be loosened. The magnet (c), which triggers the sensors, is 32 mm long and its centre is located 67 mm from the top when the unit is fully retracted.

Keep in mind that the duration of the time when the sensor is leaving a signal is dependent on the speed of the unit and the length of the magnet (32 mm). This means that the relay or input, which shall detect the signal, must be able to react on a signal with the duration in question.

1. Magnet position at fully retracted unit
2. Magnet position at fully extended unit

Figure 7: Magnet sensor

Section 4 Service and maintenance

4.1 General maintenance instructions

- The customer can perform the service and maintenance described in this manual. Other service ought to be performed by service personnel from Tollo Linear, either on-site or at a Tollo Linear Service Centre.
- Follow the recommended service intervals. Replace defective parts immediately. Only use parts of the same make and type as original. Ordering data can be found in the spare part lists supplied with the unit. Also state the manufacturing number of the unit (embossed in the drive end).
- MovoZ3 is not self-braking. This means that the load attachment plate and the load immediately fall down to the lowest position if the brake is detached. Ensure therefore that the unit is secured or is placed horizontally before the brake is detached.
- Check the unit in connection to lubrication. Particularly check for play between the outer, middle and inner profile (slide bushing wear), the function of the position indicators, the suspensions and the connection of the load. Also be attentive towards a changed level of noise. Replace, repair or adjust.
- Keep MovoZ Z3 clean. Wipe it off as required, particularly the sliding surfaces. If cleaning fluid is required, use small amounts and see to it that none gets into MovoZ Z3, do not use strong cleaning agents. Dry it fully.
- **Never** mix different types of oils / lubricants!

4.2 Lubrication

1. Lubrication of sliding surfaces

The sliding surfaces (totally 16) where the slide bushings slides must **always** be covered by a thin layer of oil of type Klüber GLY2100. Lubricate when necessary.

2. Lubrication of ball screw

The ball screw is lubricated trough the lubrication hole. Run the unit until the screw becomes visible. Lubricate with grease of type Klüber Starburags NBU30. The lubrication intervals is determined by the maximum load and the load torque the unit is subjected to, see the table below.

Note! Never put the fingers in to the lubrication hole.

Max. load	Max. load torque	Lubrication interval
0 – 250 kg	0 – 800 Nm	every 700 hour of operation
251 – 750 kg	801 – 2000 Nm	every 350 hour of operation

Table 2: Lubrication interval for ball screw

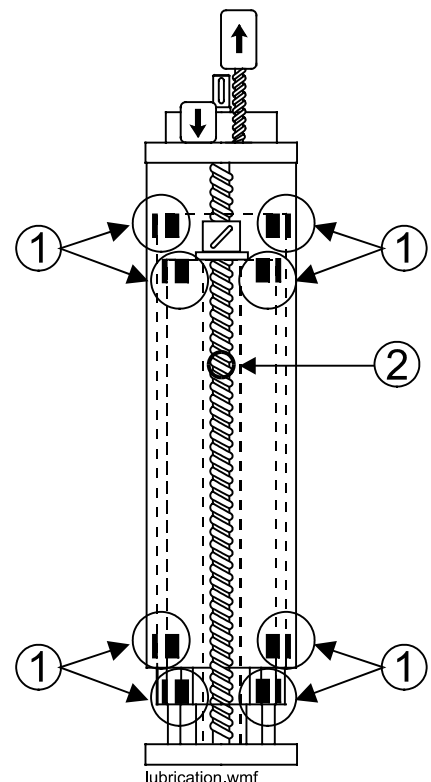

Figure 8: Lubrication

Section 5 Technical data

5.1 Technical data

MovoZ Z3		MGZ3K2510	MGZ3K2525	MGZ3K3220
Max. speed	(m/s)	0,5 ^A	1,0 ^A	0,8 ^A
Max. load	Fz (kg)	500	500	750
Max. load torque	Mx/My (N)	2000	2000	2000
Repeatability	(mm)	± 0,1	± 0,1	± 0,1
Ambient temperature	(°C)	-20 – +70	-20 – +70	-20 – +70
Linear move / shaft rev.	(mm)	10	25	20
Max. input speed	(rpm)	3000	2400	2500
Weight	(kg)	14 + (L min. ^B x 0,42)	14 + (L min. ^B x 0,42)	15 + (L min. ^B x 0,45)

^A See diagram 1 below ^B L in cm, see figure 1

Table 3: Technical data

5.2 Maximum permissible speed

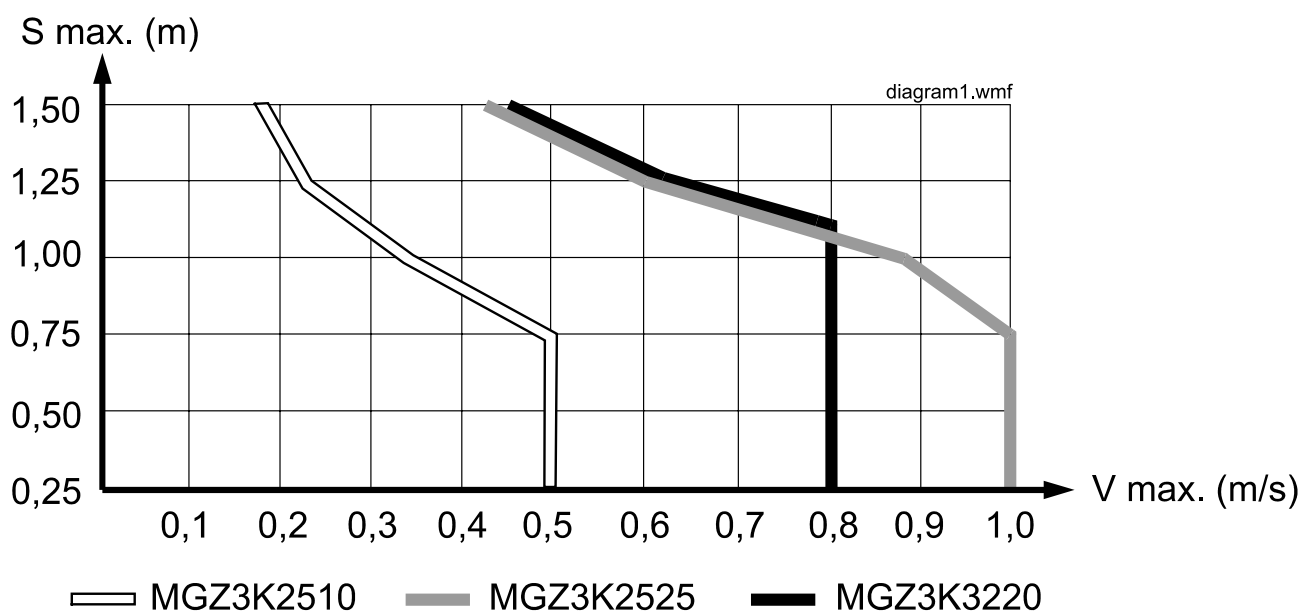

Diagram 1: Maximum permissible speed (V max.) as a function of the maximum stroke (S max.)

EUROPE**United Kingdom**

Thomson
Office 9, The Barns
Caddsdow Business Park
Bideford
Devon, EX39 3BT
Phone: +44 (0) 1271 334 500
E-mail: sales.uk@thomsonlinear.com

Germany

Thomson
Nürtinger Straße 70
72649 Wolfschlugen
Phone: +49 (0) 7022 504 0
Fax: +49 (0) 7022 504 405
E-mail: sales.germany@thomsonlinear.com

France

Thomson
Phone: +33 (0) 243 50 03 30
Fax: +33 (0) 243 50 03 39
E-mail: sales.france@thomsonlinear.com

Italy

Thomson
Largo Brughetti
20030 Bovisio Masciago
Phone: +39 0362 594260
Fax: +39 0362 594263
E-mail: info@thomsonlinear.it

Spain

Thomson
E-mail: sales.esm@thomsonlinear.com

Sweden

Thomson
Estridsväg 10
29109 Kristianstad
Phone: +46 (0) 44 24 67 00
Fax: +46 (0) 44 24 40 85
E-mail: sales.scandinavia@thomsonlinear.com

SOUTH AMERICA**Brazil**

Thomson
Av. Tamboré, 1077
Barueri, SP – 06460-000
Phone: +55 (11) 3616-0191
Fax: +55 (11) 3611-1982
E-mail: sales.brasil@thomsonlinear.com

USA, CANADA and MEXICO

Thomson
203A West Rock Road
Radford, VA 24141, USA
Phone: 1-540-833-3549
Fax: 1-540-833-0294
E-mail: thomson@thomsonlinear.com
Literature: literature.thomsonlinear.com

ASIA**Asia Pacific**

Thomson
E-mail: sales.apac@thomsonlinear.com

China

Thomson
Rm 2205, Scitech Tower
22 Jianguomen Wai Street
Beijing 100004
Phone: +86 400 6661 802
Fax: +86 10 6515 0263
E-mail: sales.china@thomsonlinear.com

India

Thomson
c/o Fluke Technologies Pvt. Ltd.
#424, Deodhar Center,
Marol Maroshi Road,
Andheri – E, Mumbai – 400059 India
Phone: +91 22 29207641
E-mail: sales.india@thomsonlinear.com

Japan

Thomson
Minami-Kaneden 2-12-23, Suita
Osaka 564-0044 Japan
Phone: +81-6-6386-8001
Fax: +81-6-6386-5022
E-mail: csjapan@scgap.com

Korea

Thomson
F7 Ilsong Bldg, 157-37
Samsung-dong, Kangnam-gu,
Seoul, Korea (135-090)
Phone: +82 2 6917 5049
Fax: +82 2 528 1456
E-mail: sales.korea@thomsonlinear.com