

# Thomson Electrak® Throttle Electric Linear Actuator

Installation Manual

Edition 2026-01



## Version History

| <b>Edition</b> | <b>Reason for revision</b>                                      |
|----------------|---|
| 2013-10        | First edition   |
| 2013-12        | Change of CANBUS information                                    |
| 2014-10        | Change of CANBUS information                                    |
| 2016-01        | Change of CANBUS information (5.2.6 Stroke calibration section) |
| 2026-01        | Updated front and back cover logotypes and layout               |
|                |   |

## Warranty

The Thomson Electrak® Throttle is warranted to be free from defects in materials and workmanship for a period of twelve (12) months from date of delivery. The application of this product is the responsibility of the buyer and Thomson makes no representation or warranty as to the suitability of the product for any particular use or purpose. For a copy of the entire warranty for this product that is contained in our standard terms and conditions of sale, please go to [http://www.thomsonlinear.com/website/com/eng/support/terms\\_and\\_conditions.php](http://www.thomsonlinear.com/website/com/eng/support/terms_and_conditions.php).

## Disclaimer

**Technical changes to improve the performance of the equipment may be made without prior notice!**

All rights reserved. No part of this work may be reproduced in any form (by printing, photocopying, microfilm or any other method) or processed, copied or distributed by electronic means without the written permission of Thomson.

Contents

- 1. General ..... 4**
  - 1.1 About this manual ..... 4
  - 1.2 Target group ..... 4
  - 1.3 Symbols used ..... 4
  - 1.4 Transport and storage ..... 4
  - 1.5 Packaging ..... 4
  - 1.6 Disposal ..... 4
  - 1.7 Support ..... 4
  
- 2. Safety ..... 5**
  - 2.1 Safety notes ..... 5
  
- 3. Standards ..... 5**
  - 3.1 EC Declaration of conformity ..... 5
  
- 4. Installation ..... 6**
  - 4.1 Product label ..... 6
  - 4.2 Terminology ..... 6
  - 4.3 Operation environment ..... 6
  - 4.4 Mechanical installation ..... 7
  - 4.5 Electrical installation ..... 8
  
- 5. CANBUS information ..... 11**
  - 5.1 Introduction to CANBUS SAE J1939 ..... 11
  - 5.2 CANBUS SAE J1939 communications protocol ..... 11
  
- 6. Technical specifications ..... 14**
  - 6.1 Technical data ..... 14
  - 6.2 Type designation key ..... 15

## 1. General

### 1.1 About this manual

This manual contains mechanical and electrical installation instructions for the Thomson Electrak® Throttle electric linear actuator. It also contains, among other things:

- technical data
- installation data
- type designation key.

It is important to carefully read this manual before installing the actuator and to have the correct qualifications needed to perform the installation.

### 1.2 Target group

This manual addresses qualified mechanical and electrical personnel.

### 1.3 Symbols used



This symbol is shown to highlight a general warning, general instruction or as a warning for a mechanical hazard.

### 1.4 Transport and storage

The actuator may only be transported and stored in the original packaging supplied by Thomson. The temperature during transportation and storage must be between -40 to +125° C (-40 to +257° F). Avoid shocks to the package. If the package is damaged, check the actuator for visible damage and notify the carrier, and if appropriate also Thomson.

### 1.5 Packaging

The packaging consists of a cardboard box. The box contains the actuator and this manual.

### 1.6 Disposal

Where required by law, used packaging and actuators are taken back by Thomson for professional disposal if the transportation cost is paid by the sender. Please contact Thomson for shipping information.

### 1.7 Support

If technical support or information is needed for this product, please contact the nearest Thomson Service Center. See the back of this manual. You can also visit [www.thomsonlinear.com](http://www.thomsonlinear.com) for information on this product and how to contact us.

## 2. Safety

### 2.1 Safety notes



- Only properly qualified personnel are permitted to perform mechanical and electrical installation of this product. Properly qualified personnel are familiar with mechanical or electrical installation work and have the appropriate qualifications for their job.
- Read this manual and any other available documentation before working on the equipment that the actuator is or shall be a part of.
- Conform strictly to the information contained in this manual and on the actuator product label on the actuator. Never exceed the performance limits stated herein.
- Never work on the actuator or its installation with the power on.
- Never unplug any cables or connectors during operation or with power on.
- Immediately stop using the actuator if it seems faulty or damaged in any way and notify an appropriate person so that corrective actions can be taken.
- Never open the actuator as that will compromise the sealing and the function of the actuator. There are no serviceable components inside.
- Grease may be present on the extension tube. Contact is non-hazardous. Film should not be removed.

## 3. Standards

### 3.1 EC Declaration of conformity

We, Thomson Linear declare that this product corresponds with the International Standard ISO 13766:2006-05 2nd Edition (Earth Moving Machinery, Electromagnetic Compatibility). The Directive 2006/42/EC annex 2.1.B, RoHSII Directive 2011/65/EU and that the standard EN ISO 12100:2010, Safety of machinery, have been applied.

**Thomson Electrak® Throttle Linear Actuator**

Product

**ETxx-xxx-xxxxxx**

Description

Can be used when the machine or the system, which it shall be, a part of is in accordance with the demands in the EEC Machinery Directive and/or other relevant regulations.

**Kristianstad 2013-11-06**

Date

**Håkan Persson**

Name

**Business Unit Manager**

Title

Signature

## 4. Installation

### 4.1 Product label

The product label can be found on the actuator housing. It will tell you which model of actuator you have and its basic performance data. Please study the product label to determine actuator type before starting any installation or service on the actuator. If you need any assistance from Thomson, please provide the manufacturing date and the designation of the actuator(s) in question.



### 4.2 Terminology

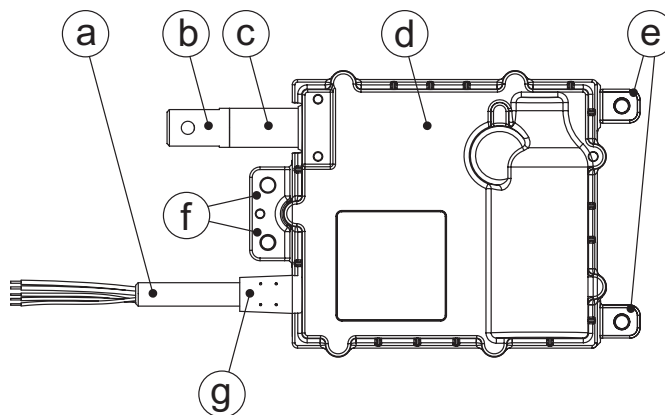

- a. cable
- b. adapter
- c. extension tube
- d. housing
- e. rear mounting holes
- f. front mounting holes
- g. cable outlet

### 4.3 Operation environment



Min. -40° C (-40° F)



1. Max. +85° C (+185° F)  
2. Max. +125° C (+257° F)



IP67 / IP69K

Operation temperature range are for:

1. Standard units: -40 to +85° Celsius (-40 to 185° Fahrenheit)
2. High temperature units: -40 (-40) to +125° Celsius (- 40 to 257° Fahrenheit).

Protection degree against the ingress of water and particles is IP67 / IP69K. Relative humidity range is 10 - 90 % non-condensing.

4.4 Mechanical installation

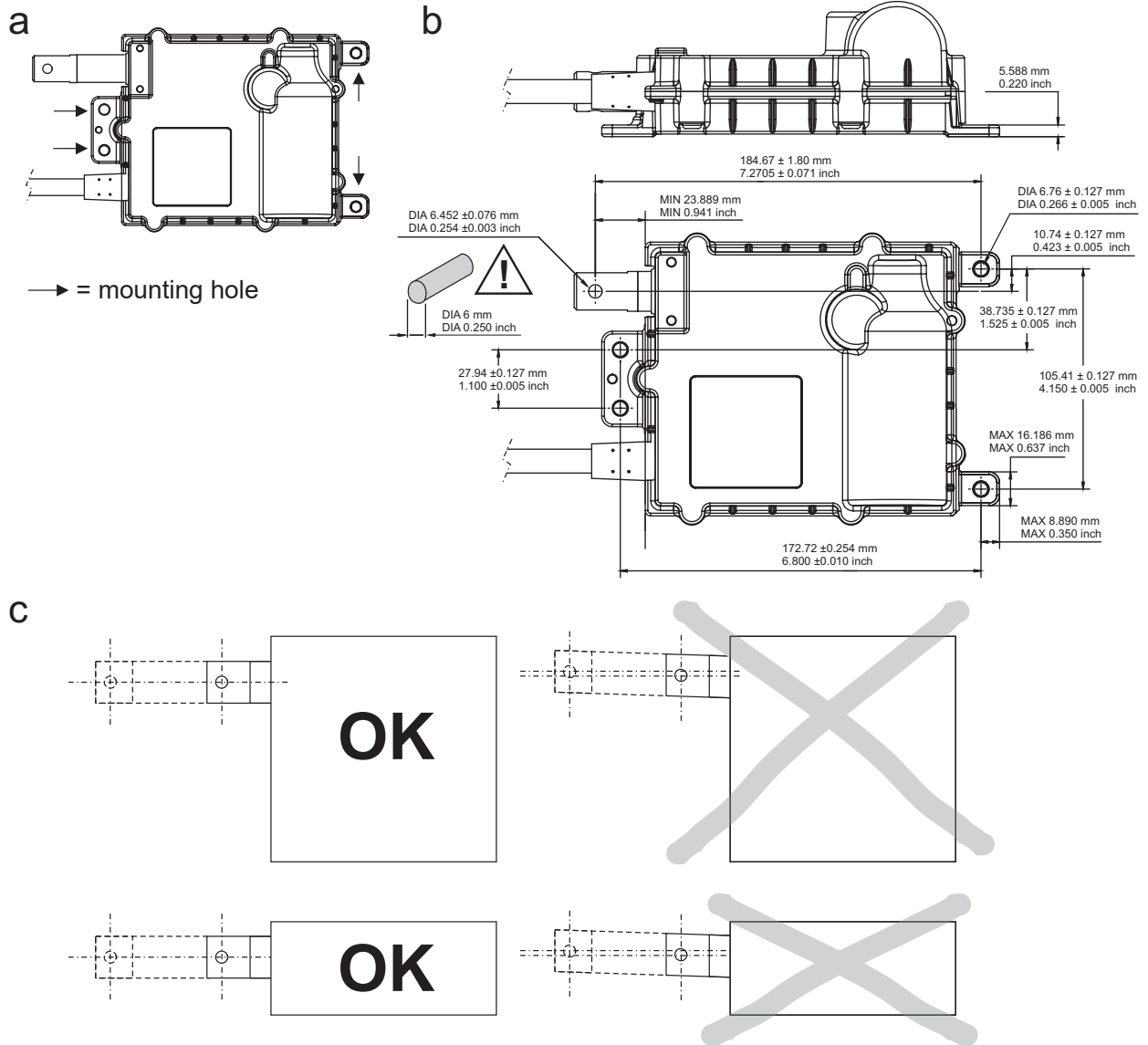

Mount the actuator to the supporting surface using at least any three of the four mounting holes (a). Attach the extension tube adapter to the load using a solid pin of diameter 6 mm (0.250 inch) (b)!. Make sure that the load being moved and the extension tube travel along the same centerline so that the tube is not exposed to any side load forces or bending load (c).

Failure modes of the actuator should be considered to ensure it does not create harm.

 **Warning!** Do not hold the extension tube while the unit is energized.

### 4.5 Electrical installation

#### 4.5.1 General notes



- Make sure the leads/cables leading to the motor can handle the maximum motor current.
- We recommend an emergency stop to avoid any crushing hazard.
- Never work on the actuator or the wiring with the power switched on!

#### 4.5.2 Fuse size

Protect the actuator and the wiring by using a slow blow fuse between the actuator and the power source.

| Recommended fuse size   |           |
|-------------------------|-----------|
| Actuator supply voltage | Fuse size |
| 12 VDC                  | 6 A       |
| 24 VDC                  | 3 A       |

#### 4.5.3 Wire cross sections

To avoid malfunction due to voltage drop the cross section of the wires between the actuator motor and the power source must be of sufficient size. For longer cables than stated in the table, calculations based on the supply voltage, the current draw, the length of the cables and the ambient temperature must be done.

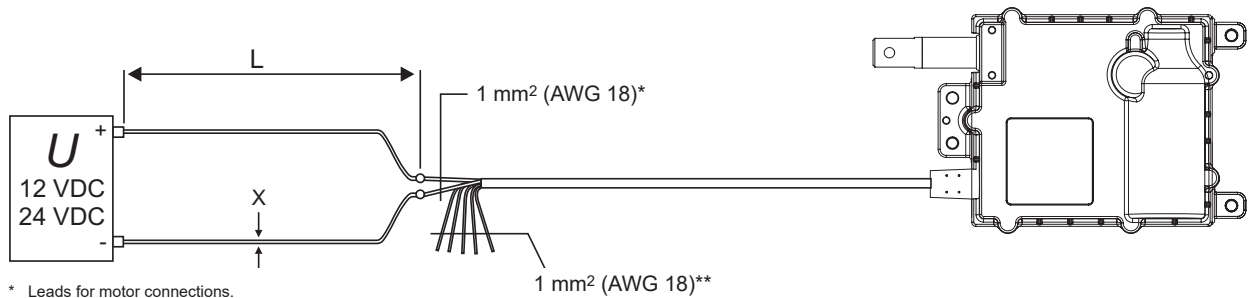

\* Leads for motor connections.  
 \*\* Leads for signal/logic connections.

| Wire cross sections |                                |
|---------------------|--------------------------------|
| Length of cable (L) | Min. allowed cross section (X) |
| 00 - 10 m           | 1.0 mm² (AWG 18)               |
| 10 - 20 m           | 1.5 mm² (AWG 16)               |

#### 4.5.4 Connector wiring configurations

The actuator is supplied with flying leads or a Deutsch DTM04-6P connector. A mating Deutsch connector kit can be ordered from Thomson (P/N 9100-448-021). **Note!** connector pin number 2 is not used but contains a sealing plug.

| Option name and order key code                          | Lead color or Deutsch DTM04-6P connector pin number |           |            |             |            |
|---|---|-----------|------------|-------------|------------|
|   | Red (1)   | Black (3) | Brown (4)  | White (5)   | Green (6)  |
| Analog position feedback sensor (NP)                    | Motor (+)   | Motor (-) | VDC in (+) | VDC out     | VDC in (-) |
| End of stroke limit switches (FN)                       | Motor (+)   | Motor (-) | -          | -           | -          |
| Analog position feedback sensor and limit switches (FP) | Motor (+)   | Motor (-) | VDC in (+) | VDC out     | VDC in (-) |
| CANBUS SAE J1939 (CN)                                   | Power (+)   | Power (-) | CAN High   | CAN Shield* | CAN Low    |

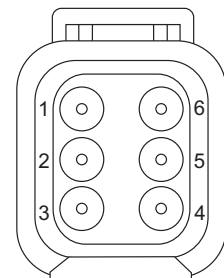

Connector rear view

\* Not required to connect.

4.5 Electrical installation

4.5.5 Installation of actuator with analog position feedback sensor (NP)

By switching the polarity of the voltage to the motor the extension tube will change direction. Any used switch must be rated for the maximum motor current.

If the actuator reaches mechanical end of stroke, the built in clutch automatically will stop the motion. The clutch is a safety feature and should not be used as end of stroke control during normal operation!

| Analog Feedback Sensor Specifications                         |       |                              |
|---|-------|------------------------------|
| Input voltage, max. (VDC in)                                  | [VDC] | 32                           |
| Output voltage (VDC out) at fully retracted at fully extended | [VDC] | < 5 % VDC in<br>> 75% VDC in |
| Max. output current   | [mA]  | 1                            |
| Linearity   | [± %] | 1                            |

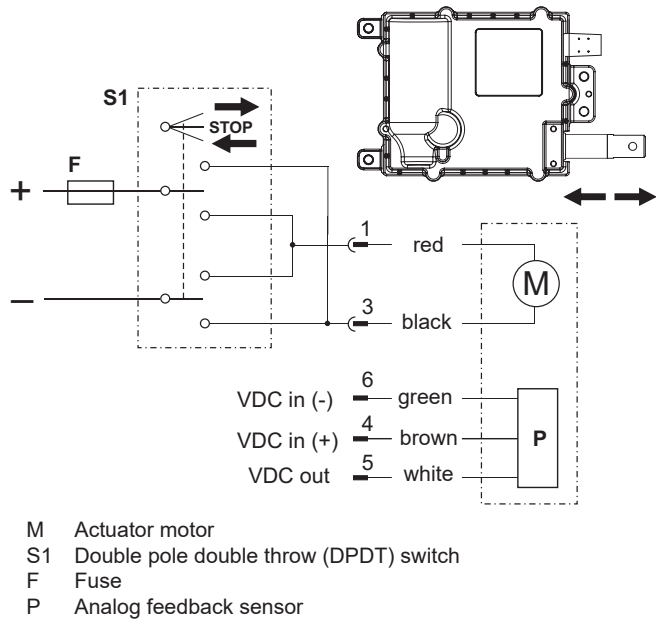

4.5.6 Installation of actuator with end of stroke limit switches (option FN) or actuator with end of stroke limit switches and analog position feedback sensor (FP)

By switching the polarity of the voltage to the motor the extension tube will change direction. Any used switch must be rated for the maximum motor current.

When reaching the ends of stroke the internal limit switches automatically will stop motion. A clutch is included as a safety feature to stop the motion and protect the actuator in case of mechanical overload.

| Analog Feedback Sensor Specifications                         |       |                              |
|---|-------|------------------------------|
| Input voltage, max. (VDC in)                                  | [VDC] | 32                           |
| Output voltage (VDC out) at fully retracted at fully extended | [VDC] | < 5 % VDC in<br>> 75% VDC in |
| Max. output current   | [mA]  | 1                            |
| Linearity   | [± %] | 1                            |

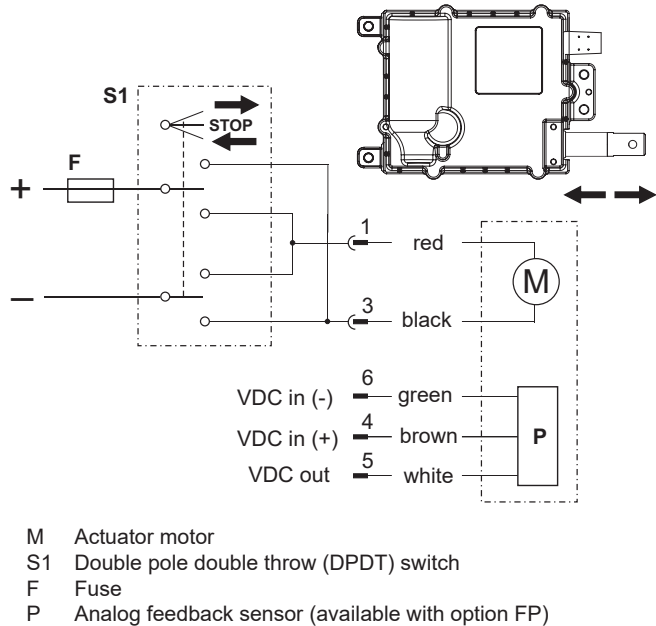

## 4.5 Electrical installation

### 4.5.7 Installation of actuator with CANBUS SAE J1939 (CN)

This document assumes the reader is familiar with the SAE J1939 standard. Terminology from the standard is used, but not described in detail. See section 5 for information on the CANBUS operation and communication protocol.

#### 4.5.7.1 General installation data

Voltage is to be directly connected to the actuator. Polarity reversal is not required as position is controlled through the communication bus. When reaching the ends of stroke the internal electronic limit switches will automatically stop motion.

#### 4.5.7.2 CANBUS SAE J1939 installation data

As per ISO-11898 Standard CAN 2.0B, Protocol SAE J1939, CAN Shield is an optional ground termination for jacket shielded cables, but is not required for operation. Proper termination resistors (120 Ohm) should be placed in mating wire harness, see below. Please refer to section 5 for more communication details.

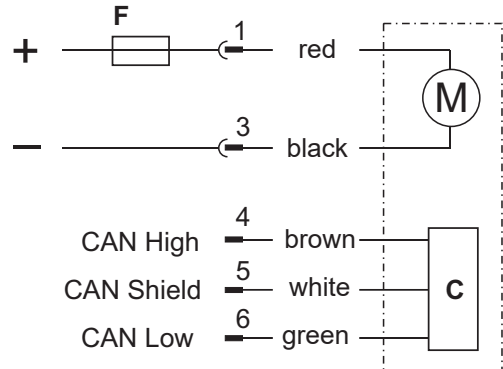
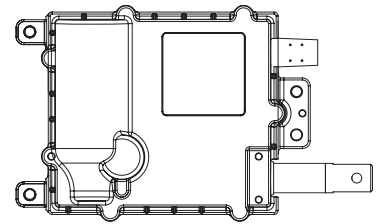

- M Actuator motor
- F Fuse
- C CANBUS interface

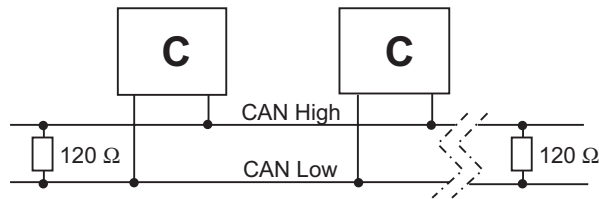

## 5. CANBUS Information

### 5.1 Introduction to CANBUS SAE J1939

This document assumes the reader is familiar with the SAE J1939 standard. Terminology from the standard is used, but not described in detail. The Electrak® Throttle actuator is compliant with the standard J1939, and supports the following PGNs (Parameter Group Number) from the standard.

#### J1939-21 – Data Link Layer

- Proprietary A 61184 (0x00EF00)
- Proprietary B 65280 (0x00FF00)

#### J1939-71 – Vehicle Application Layer

- Engine Throttle / Fuel Actuator Control Command (TFAC) 61466 (0x00F01A)
- Fuel Economy (LFE1) 65266 (0x00FEF2)

#### J1939-81 – Network Management

- Address Claimed/Cannot Claim 60928 (0x00EE00)
- Commanded Address 65240 (0x00FED8)

### 5.2 CANBUS SAE J1939 communications protocol

#### 5.2.1 J1939 NAME

The Electrak® Throttle has the following defaults for the J1939 NAME. Please refer to the SAE J1939/81 standard for more information on these parameters.

| J1939 NAME Defaults       |                         |
|---------------------------|-------------------------|
| Arbitrary Address Capable | Yes                     |
| Industry Group            | 0, Global               |
| Vehicle System Instance   | 0                       |
| Vehicle System            | 0, Non-specific system  |
| Function                  | 144, Throttle           |
| ECU Instance              | 0, First instance       |
| Manufacture Code          | 547, Thomson Linear LLC |
| Identity Number           | 0                       |

#### 5.2.2 Address

The Electrak® Throttle uses a default address value of 18 (0x12). The user must also be aware that since the device is arbitrary address capable, if another device with a higher priority NAME contends for the selected address, the actuator will continue to request other addresses until it finds one that it can claim. The user can also use the commanded address PGN to select a specified address. See J1939/81 for more details about address claiming.

#### 5.2.3 Sleep operation

The Electrak® Throttle utilizes a sleep mode operation when positioning is no longer required. This feature allows for a constant battery connection with minimal drain while the engine or vehicle is not running. After 5 seconds of bus inactivity, the actuator will put itself in a state of sleep. During this state the quiescent current is <1.2 mA for 12 VDC models and <2.4 mA for 24 VDC models. When bus activity is restored the actuator will begin a wake up phase, followed by an address claim request.

## 5.2 CANBUS communications protocol

### 5.2.4 J1939 Actuator Positioning Control

Positional control is completed using SPN 3464 (Engine Throttle Actuator 1 Control Command) within PGN 61466 (Engine Throttle / Fuel Actuator Control Command). The preferred transmission repetition rate of this PGN is 50 ms. The SPN has a data length of 2 Bytes with a resolution of 0.0025 %/bit and 0 offset. Operational range is limited from 0 - 100 %, which will linearly control actuator stroke from 0 % being fully retracted to 100 % being fully extended. Further PGN and SPN details can be found in the SAE J1939/71 (PGN 61466 / SPN 3464) specification, or by contacting customer support.

### 5.2.5 J1939 Actuator Position Feedback

Actuator positional feedback is gathered using SPN 51 (Engine Throttle Valve 1 Position) within PGN 65266 (Fuel Economy (Liquid)). The transmission repetition rate for this message is 100 ms. The SPN has a data length of 1 Byte with a resolution of 0.4 %/bit and 0 offset. Operational range is from 0 - 100 %, which will linearly coincide to actuator stroke from 0 % being fully retracted to 100 % being fully extended. Further PGN and SPN details can be found below or in the SAE J1939/71 (PGN 65266 / SPN 51) specification, or by contacting customer support.

### 5.2.6 J1939 Actuator System Control

The proprietary A message may be used to request additional actuator system non-positional information. This 8 Byte message can perform specific tasks when sent request values in Byte 1. Bytes 2 – 8 are reserved for factory use and the user should fill these Bytes with 0x00 when sending messages. There is no specific transmission repetition rate for this message but it is recommended to only be transmitted when specific data is required. Further PGN details can be found in the SAE J1939/21 specification.

| Actuator System Control Commands |  |
|----------------------------------|--|
| Byte 1, bit 8 - 4                | XXXXX = Future Use (Recommended to fill with 00000)  |
| Byte 1, bit 3 - 1                | 00X = Future Use<br>010 = Future Use<br>011 = Perform actuator stroke calibration<br>100 = Perform immediate halt of actuator movement<br>101 = Request actuator status report<br>11X = Future Use |
| Byte 2 - 8                       | 0xXX = Future Use (Recommended to fill with 0x00 for each Byte)  |

#### Stroke Calibration

This function commands the actuator to perform a full extend and retract cycle. The actuator stroke calibration feature is designed for use in applications that require a stroke less than 50.8 mm (2 in), but still need a positional feedback signal that has the full range from 0 - 100 %. This command, when requested, will automatically cause the actuator to fully retract, to minimum allowed in the application, followed by fully extending. At the end of this routine the actuator will re-configure the positional feedback to give 0 - 100 % for the allowed stroke length. A mechanical clutch ratcheting may be heard at each end of stroke for a period of <500 ms.



Although current limits are set to prevent internal overload care should be taken to avoid a crushing hazard.

#### Immediate Motor Halt

The motor halt feature is designed to give a user the ability to stop any motion currently being performed by causing an immediate dynamic braking effect on the motor. This feature may be used in an emergency stopping condition.

#### Status Report Request

The status request feature allows the user to gather information on non-positional actuator data. More information on this data is located in the J1939 Actuator Status Report section.

## 5.2 CANBUS communications protocol

### 5.2.7 J1939 Actuator Status Report

Along with the standard application layer PGNs, more status data can be collected with the use of the proprietary B message. Feedback on voltage, current, temperature, position, and calibration can all be gathered using this message. There is no specific transmission repetition rate for this message but it is automatically sent on an error flag transition or when requested using a Proprietary A message. Further PGN details can be found in the SAE J1939/21 specification.

#### Voltage Error

The error flag is set when input battery voltage is outside the operational range. This range is 9 - 16 VDC on 12 VDC systems and 18 - 32 VDC on 24 VDC actuators. Actuator motion will not begin if outside these ranges, however if motion has already been started it will complete the move before prohibiting additional motion.

#### Temperature Error

The error flag is set when the internally measured temperature is outside operational ranges. This limit is set at -40° C (-40° F) and +85° C (+185° F). The optional high temperature version utilizes the same low setting but is available up to +125° C (+257° F). Actuator motion will not begin outside these ranges, however if motion has already been started it will complete the move before prohibiting additional motion.

#### Calibration Error

The error flag is set when internal electronic control has determined the Stroke Calibration routine has not properly run, configured, or stored its calibration results. The user should perform a Stroke Calibration to clear this error state.

#### Current Error

The error flag is set when motor current draw has exceeded that allowed by the internal electronic control system. This limit is set at 4.5 A for 12 VDC systems and 2.25 A for 24 VDC systems. Actuator motion will stop immediately when this condition has occurred. To continue motion the user must change the positional command percentage from the value when the fault occurred.

#### Position Error

The error flag is set when the motor is in motion, but no linear force is generated. This Error works alongside the current error in preventing actuator overloads. This error is seen when the actuator stroke is limited externally within the calibrated values and the internal mechanical clutch is disengaged, prohibiting motion. This error occurrence can be reduced by performing a Stroke Calibration routine using a Proprietary A message located in the J1939 Actuator System Control section.

| Actuator System Status Report Messages |                   |   |
|--|-------------------|---|
| Voltage Error                          | Byte 1, bit 2 - 1 | 00 = No Fault<br>01 = Voltage outside operational range<br>1X = Future Use                        |
| Current Error                          | Byte 1, bit 4 - 3 | 00 = No Fault<br>01 = Unit has exceeded maximum running current<br>1X = Future Use                |
| Temperature Error                      | Byte 1, bit 6 - 5 | 00 = No Fault<br>01 = Unit is outside operational temperature range<br>1X = Future Use            |
| Position Error                         | Byte 1, bit 8 - 7 | 00 = No Fault<br>01 = Unit has not detected positional movement when commanded<br>1X = Future Use |
| Calibration Error                      | Byte 2, bit 2 - 1 | 00 = No Fault<br>01 = Unit has faulted during a calibration routine<br>1X = Future Use            |
| -                                      | Byte 2, bit 8 - 3 | XXXXXX = Future Use   |
| -                                      | Byte 3 - 8        | 0xXX = Future Use   |

## 6. Technical Specifications

### 6.1 Technical data

| Technical Specification <sup>(1)</sup>                 | ET ••                      |            |            |            |
|--|----------------------------|------------|------------|------------|
| Input voltage [VDC]                                    | 12                         | 24         |            |            |
| Input voltage tolerance [VDC]                          | 9 - 16                     | 18 - 32    |            |            |
| Stroke length [mm (inch)]                              | 50.8 (2.0)                 |            |            |            |
| Retracted length [mm (inch)]                           | 184.7 (7.27)               |            |            |            |
| <b>Performance</b>                                     |                            |            |            |            |
| Model  | ET12 - 084                 | ET12 - 174 | ET24 - 084 | ET24 - 174 |
| Static load (Fx), maximum [N (lbs)]                    | 90 (20)                    | 260 (60)   | 90 (20)    | 260 (60)   |
| Dynamic load (Fx), maximum [N (lbs)]                   | 45 (10)                    | 130 (30)   | 45 (10)    | 130 (30)   |
| Speed, no load [mm/s (inch/s)]                         | 96 (3.7)                   | 48 (1.9)   | 96 (3.7)   | 48 (1.9)   |
| Speed, rated load [mm/s (inch/s)]                      | 83 (3.3)                   | 37 (1.45)  | 83 (3.3)   | 37 (1.45)  |
| Current draw @ rated max. load [A]                     | 4                          |            | 2          |            |
| Current draw @ stall/in-rush [A]                       | 12                         |            | 6          |            |
| <b>General data</b>                                    |                            |            |            |            |
| Weight [kg (lbs)]                                      | 1.11 (2.5)                 |            |            |            |
| End play, maximum [mm (inch)]                          | 1.5 (0.06)                 |            |            |            |
| Operating temperature limits, standard units [°C (°F)] | -40 to +85 (-40 to +185)   |            |            |            |
| Operating temperature limits, hi temp units [°C (°F)]  | -40 to +125 (-40 to + 257) |            |            |            |
| Full load duty cycle @ 25 °C [%]                       | 50                         |            |            |            |
| Life [cycles]  | 500 000                    |            |            |            |
| Restraining torque [Nm (lbf-in)]                       | 0 (internally restrained)  |            |            |            |
| Motor cable lead cross section [mm <sup>2</sup> (AWG)] | 0.8 (18)                   |            |            |            |
| Motor cable length [mm (in)]                           | 165 (6.5)                  |            |            |            |
| Protection class                                       | IP67 / IP69K               |            |            |            |
| Certifications   | CE, RoHS                   |            |            |            |

(1) Specifications are subject to change without notice. It is the responsibility of the product user to determine the suitability of this product for a specific application.

## 6.2 Ordering Key

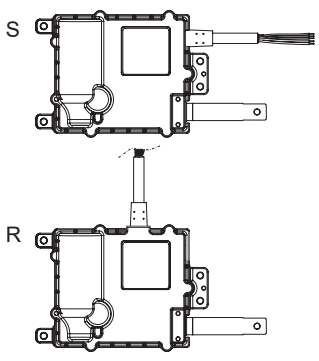
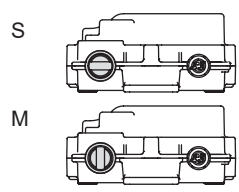
| Ordering Key   |              |             |   |          |           |   |          |
|--|--------------|-------------|---|----------|-----------|---|----------|
| Position   | 1            | 2           | 3   | 4        | 5         | 6   | 7        |
| Example  | <b>ET12-</b> | <b>174-</b> | <b>S</b>  | <b>S</b> | <b>NP</b> | <b>1</b>  | <b>S</b> |
| <p>1. Actuator type and supply voltage<br/>                     ET12- = Electrak® Throttle, 12 VDC<br/>                     ET24- = Electrak® Throttle, 24 VDC</p> <p>2. Max. dynamic load and speed version<br/>                     084- = 45 N (10 lbf), high speed*<br/>                     174- = 130 N (30 lbf), standard speed</p> <p>3. Harness orientation<br/>                     S = exit parallel to adapter<br/>                     R = exit rotated 90° in housing</p>  |              |             | <p>4. Temperature rating<br/>                     S = standard: -40 (-40) to +85 (+185) °C (F)<br/>                     E = high temp: -40 (-40) to +125 (+257) °C (F)*</p> <p>5. Control option<br/>                     NP = analog position feedback sensor<br/>                     FN = end of stroke limit switches<br/>                     FP = analog position feedback sensor and end of stroke limit switches<br/>                     CN = CANBUS SAE J1939</p> |          |           | <p>6. Connection options<br/>                     1 = flying leads<br/>                     2 = Deutsch DTM04-6P</p> <p>7. Adapter options<br/>                     S = standard adapter orientation<br/>                     M = adapter rotated 90°</p>  |          |

\* The high speed (084-) version can only be ordered with the high temperature (E) rating and vice versa. Note that there is no thermal switch to protect the motor on the high temperature rated models.

Contact us or any of our 2000+ global distribution partners by scanning the code below  
or visiting [www.thomsonlinear.com/contact](http://www.thomsonlinear.com/contact)



**RegalRexnord™**

[www.regalrexnord.com](http://www.regalrexnord.com)

[www.thomsonlinear.com](http://www.thomsonlinear.com)

Electrak\_Throttle\_Installation\_Operation\_MNUK-0001-05 | 20260122KB  
Specifications are subject to change without notice. It is the responsibility of the product user to determine the suitability of this product for a specific application. All trademarks property of their respective owners. ©2026 Thomson Industries, Inc. | 2400 Curtiss Street, Downers Grove, IL 60515 USA

** THOMSON®**