

Get moving with the first collaborative 7th axis

The Thomson Movotrak cobot transfer unit (CTU) is a plug-and-play system with up to 10 meters of horizontal operating range, which can help boost productivity for various robotic functions. With flexible mounting options, it's compatible with the largest sized cobots on the market.



Robot not included

Features & Benefits

- User-adjustable collision detection settings allow users to set the sensitivity of the 7th axis per the application requirements.
- 7th axis Freedrive mode allows hand-driven movements to set linear waypoints during programming.
- Dual-linear-unit design delivers maximum moment load and stiffness, even when the cobot arm is fully extended.
- Flexible mounting options (horizontal, inverted, wall-mounted) allow users to optimize their work spaces.

Additional Resources



Watch the Movotrak CTU
in action



Sign up for a live demo

Applications

- Large part testing and inspection
- Machine tending
- Material handling (bin picking, palletizing and packaging)
- Large-scale welding, soldering, sanding and dispensing



7th Axis Mechanical Assembly

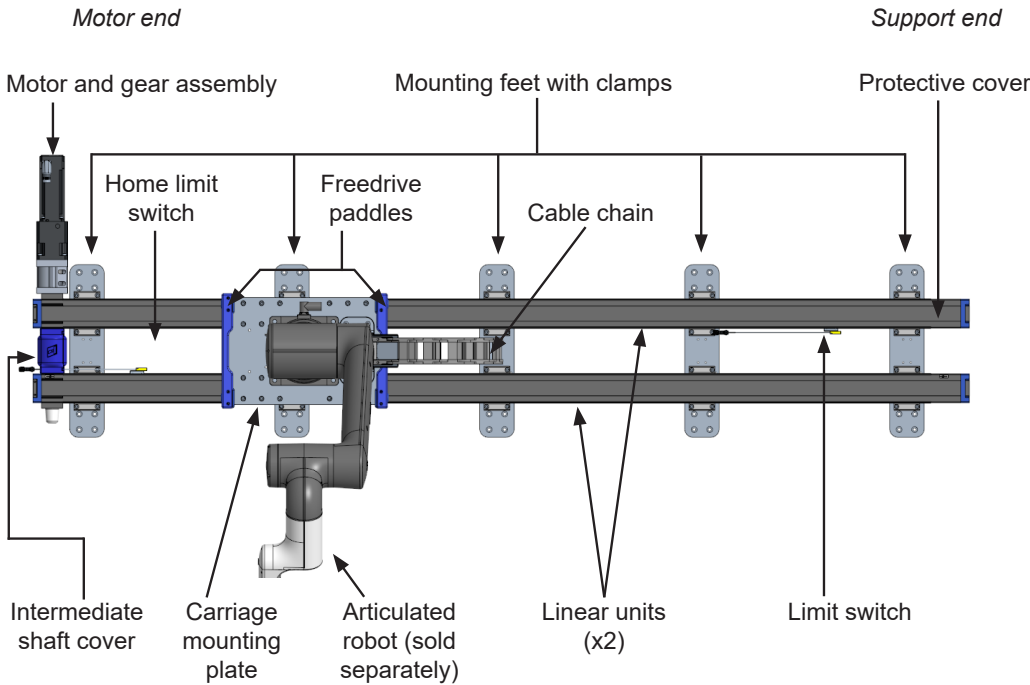

Included: Dual linear units, Kollmorgen servo motor, precision gearhead, carriage mounting plate for robot, Freedrive paddles, end-of-stroke limit switches, cable management, control box and software with 7th axis collision detection. Ecosystem Package for ABB GoFa cobots (coming soon).

Ordering Key

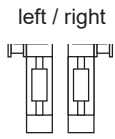
Position	1	2	3	4	5	6
Example	CTU07	B	R	04500	ABB12	A
1. CTU type and size CTU07 = Movotrak CTU size 07 (Movopart M75 linear unit)	2. Drive type B = belt drive		3. Motor configuration L = motor on left side R = motor on right side		5. Type and size of articulated robot ABB5 = ABB GoFa 5 kg ABB10 = ABB GoFa 10 kg ABB12 = ABB GoFa 12 kg	
4. Stroke length XXXX = stroke in millimeters			6. Base plate A = Standard. For 45 series extrusion. B = For 50 mm series extrusion. C = For weldment. M10 holes. S = Custom holes for table/weldment. Contact Thomson.			

Notes

- Repeatability of ± 25 $\mu\text{m}/\text{m}$ of stroke.
- Light washdown options available.
Contact Thomson for details.

Already using an industrial robot?

The Thomson industrial robot transfer unit (RTU) allows you to quickly and easily equip your industrial robotic applications with a 7th axis. Integrate your motor in less than a minute with the Thomson RediMount™ motor mounting adapter kit and use your own robotic controller.

Included: Dual linear units, precision gearhead, motor mounting adapter kit, carriage mounting plate for robot, end-of-stroke limit switches and cable management.

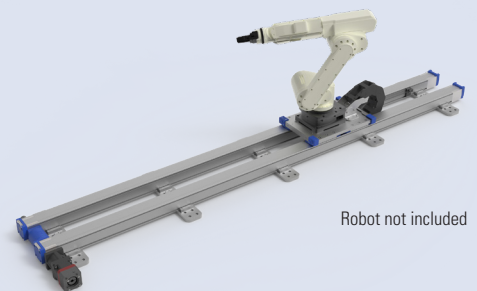

thomsonlinear.com/ctu

Movotrak_CTU_BREN-0050-03 | 20250306KB
Specifications are subject to change without notice. It is the responsibility of the product user to determine the suitability of this product for a specific application. All trademarks property of their respective owners. ©2024 Thomson Industries, Inc.

THOMSON
A REGAL REYNOLD BRAND