

# Thomson Movotrak Cobot Transfer Unit

## A Collaborative 7<sup>th</sup> Axis Solution for Cobots

Installation Manual

Edition 2024-12



## Version history

<b>Edition</b>	<b>Reason for revision</b>
2023-06	First edition
2024-02	Updated safety section and new images of the control cabinets
2024-12	Multiple mounting and installation updates. Sections 9 and 10 added.

## Warranty

The Thomson Movotrak Cobot Transfer Unit is warranted to be free from defects in materials and workmanship for a period of twelve (12) months from date of delivery. The application of this product is the responsibility of the buyer and Thomson makes no representation or warranty as to the suitability of the product for any particular use or purpose. For a copy of the entire warranty for this product that is contained in our standard terms and conditions of sale, please go to [http://www.thomsonlinear.com/website/com/eng/support/terms\\_and\\_conditions.php](http://www.thomsonlinear.com/website/com/eng/support/terms_and_conditions.php).

## Disclaimer

**Technical changes to improve the performance of the equipment may be made without prior notice!**

Thomson disclaims any and all liability if the Movotrak CTU (mechanical actuators, motor, sensors, and/or control panel) is damaged, changed or modified in any way. Thomson cannot be held responsible for any damages caused to the Movotrak CTU or any other equipment due to programming errors or malfunctioning of the Movotrak CTU.

All rights reserved. No part of this work may be reproduced in any form (by printing, photocopying, microfilm or any other method) or processed, copied or distributed by electronic means without the written permission of Thomson.

## Contents

<b>1. General</b> .....	<b>4</b>
1.1 About this manual.....	4
1.2 Target group.....	4
1.3 Symbols used.....	4
1.4 Transport and storage.....	4
1.5 Packaging.....	4
1.6 Disposal.....	4
1.7 Support.....	4
<b>2. Safety and and declaration of conformity</b> .....	<b>5</b>
2.1 Safety notes.....	5
2.2 Validity and responsibility.....	5
2.3 Warnings.....	6
2.4 Intended use.....	6
2.5 EU Declaration of incorporation of partly completed machinery.....	7
<b>3. Product identification and dimensions</b> .....	<b>8</b>
3.1 Product label.....	8
3.2 Product model number/ordering key.....	9
3.3 List of components and terminology.....	10
3.4 Dimensions.....	11
<b>4. Mechanical installation</b> .....	<b>12</b>
4.1 General preparations.....	12
4.2 Tools required.....	12
4.3 Moving and lifting.....	12
4.4 Mounting.....	14
<b>5. Electrical installation and software setup</b> .....	<b>26</b>
5.1 Connecting the Movotrak CTU to the Universal Robots control system.....	26
5.2 Basic setup.....	27
5.3 Setting up move parameters and sensitivity.....	31
<b>6. Programming of the Movotrak CTU system</b> .....	<b>33</b>
6.1 General requirements.....	34
6.2 Programming.....	34
<b>7. Collision detection system</b> .....	<b>37</b>
7.1 Activation.....	37
<b>8. Troubleshooting</b> .....	<b>38</b>
8.1 Troubleshooting.....	38
<b>9. Technical data</b> .....	<b>39</b>
9.1 Technical specifications.....	39
<b>10. Certificates</b> .....	<b>40</b>
10.1 RoHS declaration.....	40
10.2 Kollmorgen declarations.....	42

## 1. General

### 1.1 About this manual

This manual contains mechanical and electrical installation instructions for the Thomson Movotrak Cobot Transfer Unit (Movotrak CTU) system. It also contains, among other things:

- technical data
- installation data
- ordering key.

It is important to carefully read this manual before installing the system and to have the correct qualifications needed to perform the installation.

### 1.2 Target group

This manual addresses qualified mechanical and electrical personnel.

### 1.3 Symbols used



This symbol is shown to highlight a general warning, general instruction or as a warning for a any type of hazard.



This symbol is shown to highlight a general tip or suggestion.

### 1.4 Transport and storage

The Movotrak CTU may only be transported and stored in the original packaging supplied by Thomson. The temperature during transportation and storage must be between -40 to +85° C (-40 to +185° F). Avoid shocks to the package. If the package is damaged, check the content for visible damage and notify the carrier, and if appropriate Thomson as well.

### 1.5 Packaging

The Movotrak CTU ships in multiple packages with the linear slides in standard long wood or cardboard crates and all the other parts in a wooden crate. To lift and move some of these packages lifting aids are required. See section 4.3. For large quantity orders, bulk packaging may be used, in which case the packaging and the content will vary depending on the order agreement.

### 1.6 Disposal

Where required by law, used packaging and Movotrak CTU parts are taken back by Thomson for professional disposal if the transportation is paid by the sender. Please contact Thomson for shipping information.

### 1.7 Support

If technical support or information is needed for this product, please contact the nearest Thomson Service Center. See the back of this manual. You can also visit [www.thomsonlinear.com](http://www.thomsonlinear.com) for information on this product and how to contact us.

## 2. Safety and Declaration on Conformity

### 2.1 Safety notes



- Only properly qualified personnel are permitted to perform mechanical and electrical installation of this product. Properly qualified personnel are familiar with mechanical or electrical installation work and have the appropriate qualifications for their job.
- Read this manual and any other available documentation before working on the equipment that the CTU is or shall be a part of.
- Conform strictly to the information contained in this manual and on the Movotrak CTU product label on the system. Never exceed the performance limits stated herein.
- Never work on the Movotrak CTU or its installation with the power on.
- Never unplug any cables or connectors during operation or with power on.
- Immediately stop using the Movotrak CTU if it seems faulty or damaged in any way and notify an appropriate person so that corrective actions can be taken.
- Never open the any of the Movotrak CTU components as that will compromise the sealing and the function of the system. There are no serviceable components inside.
- Collision detection settings are provided for your convenience. These are not official safety features. User is responsible for conducting their own risk analysis. When applicable, third-party safety devices should be used.
- Carefully follow electrical and wiring instructions to ensure emergency stop and safeguard stop I/O has been connected between the articulated robot and the Movotrak CTU system.
- Lift and move the boxes, crates and system parts as described in section 4.3.
- The cabinet main switch handle can be locked during setup or maintenance using the grey lock lever (a). Additional requirements for lock-out may vary by region or facility and should always be followed.



### 2.2 Validity and responsibility

The information in this manual does not cover designing, installing and operating a complete Movotrak CTU system and robot application, nor does it cover all peripheral equipment that can influence the safety of the complete system. The Movotrak CTU itself is partly completed machinery and the safety of the overall application depends upon how the Movotrak CTU is integrated with the collaborative robot, end effectors, obstacles, and other machinery. The complete system must be designed and installed in accordance with the safety requirements set forth in the standards and regulations of the country where the robot is installed. The integrators of collaborative robots are responsible for ensuring that the applicable safety laws and regulations in the country concerned are observed and that any significant hazards in the complete robot application are eliminated. This includes, but is not limited to:

- Performing a risk assessment for the complete robot system.
- Interfacing other machines and additional safety devices if defined by the risk assessment.
- Setting up the appropriate settings in the software.
- Validating that the Movotrak CTU and total robot system is designed and installed correctly
- Specifying instructions for use.

## 2.3 Warnings

This section contains some general warnings and cautions that can be repeated or explained in different parts of this manual. Other warnings and cautions are present throughout this manual.



1. Make sure all parts of the Movotrak CTU system and the robot are properly and securely bolted in place.
2. The Movotrak CTU system is intended for permanent installation on a fixed frame and any disassembly, transport and re-installation requires the system to be re-aligned.
3. Make sure the Movotrak CTU linear unit has ample space to operate freely.
4. Do not wear loose clothing or jewellery when working with the Movotrak CTU system.
5. Make sure long hair is tied back when working with the Movotrak CTU system.
6. Never use the Movotrak CTU system if it is damaged.
7. The Movotrak CTU system freedrive function shall only be used in installations where the risk assessment allows it.
8. Tool/end effectors and obstacles shall not have sharp edges or pinch points.
9. Make sure to warn people to keep their heads and faces outside the path of any moving parts.
10. Be aware of the Movotrak CTU linear unit movement when using the teach pendant.
11. If determined by the risk assessment, do not enter near the operation range of the Movotrak CTU system or touch it when the system is in operation.
12. Collisions can release high levels of kinetic energy, which are significantly higher at high speeds and with high payloads.
13. Combining different machines can increase hazards or create new hazards.
14. Always make an overall risk assessment for the complete installation.
15. Never modify the Movotrak CTU system. A modification might create hazards that are unforeseen by the risk assessment.

## 2.4 Intended use

The Movotrak CTU is intended to transfer collaborative robots along with their tools and end effectors.

As with collaborative robots, collaborative operation is only intended for non-hazardous applications, where the complete application – including the Movotrak CTU linear unit, collaborative robot, end effectors, obstacles, and other machines is without any significant hazards according to the risk assessment of the specific application.

Any use or application deviating from intended use is deemed to be impermissible misuse. This includes but is not limited to:

- Use in potentially explosive environments
- Use in medical and life critical applications
- Use before performing a risk assessment
- Use outside of stated specifications
- Use as a climbing aid
- Operation outside the permissible operating parameters

## 2.5 EU Declaration of incorporation of partly completed machinery

### CE Declaration of Conformity for partially completed machinery



**We, the company**

Tollo Linear AB, Bredbandsvägen 12, 291 62 Kristianstad, Sweden

**Hereby in sole responsibility declare the conformity of the product series**

MovoTrak CTU (part numbers beginning with "CTU")

A partially completed machine consisting of a linear actuator system with control box to manipulate an industrial robot along an axis. Overall function is determined by the completed machine with robot, end effector, and intended use.

**Manufactured by**

Tollo Linear AB, Bredbandsvägen 12, 291 62 Kristianstad, Sweden  
Thomson Industries, Avenida Los Cabos, Edificio N-3 Parque Industrial Nordika,  
Tijuana, BC Mexico C.P 22645

**With the following directive**

- EC-Directive 2006/42/EC – Machine Directive (MD)

The following essential requirements have been fulfilled: 1.1.3, 1.1.5, 1.2.4.3, 1.2.6, 1.3.8.1, 1.5.1, 1.5.2, 1.5.6, 1.5.10, 1.6.3, 1.7.2, 1.7.3, 1.7.4.1, 1.7.4.3, 4.1.2.3, 4.1.2.2

**And further directive(s)**

- EMC Directive 2014/30/EU

EN55011: Industrial, Scientific, and medical equipment  
Electrical fast transient burst EN61000-6-2  
Electrostatic discharge immunity test EN61000-4-2  
Burst Immunity Test EN61000-4-4  
Surge Immunity Test EN61000-4-5  
RF Immunity Test EN61000-4-6

- Low Voltage Directive 2014/35/EU, using the following harmonized standard:

For Servo Drive Component:

EN61800-5-1: 2007+A1:2017+A11:201 Adjustable Speed Electrical Power Drive Systems - Part 5-1

For Servo Motor Component:

EN 60034-1:2010/AC:2010 Rotating electrical machines Part 1  
EN 60034-5:2001/A1:2007 Rotating electrical machines Part 5

**Year of first Declaration:** 2024

Safety depends upon installing and configuring the MovoTrak CTU per the manufacturer's recommendations. Thomson MovoTrak 7th Axis CTU shall only be put into service upon being integrated into a final complete machine (robot system, cell, or application) which conforms with the provisions of the Machinery Directive and other applicable Directives. The installer is responsible for ensuring that the end product complies with the requirements and all the relevant laws in the country where the equipment is installed.

**Issued by:**

Product Line Manager

Mr. Hans Dahlen

Kristianstad, 2024-11-21

Legally valid signature

**Responsible person for technical documentation:**

Mr. Peter Gnebnér, Tollo Linear AB, Bredbandsvägen 12, 291 62 Kristianstad, Sweden

Doc. No: XXXXXX

### 3. Product identification and dimensions

#### 3.1 Product label

There are two product labels (see images below) which both can be found on the control cabinet. They will tell you which model of Movotrak CTU you have, its basic performance data and where it is manufactured. Please study the product labels to determine CTU type before starting any installation or service on the CTU. If you need any assistance from Thomson, please provide the serial number, manufacturing date and the designation of the CTU(s) in question.

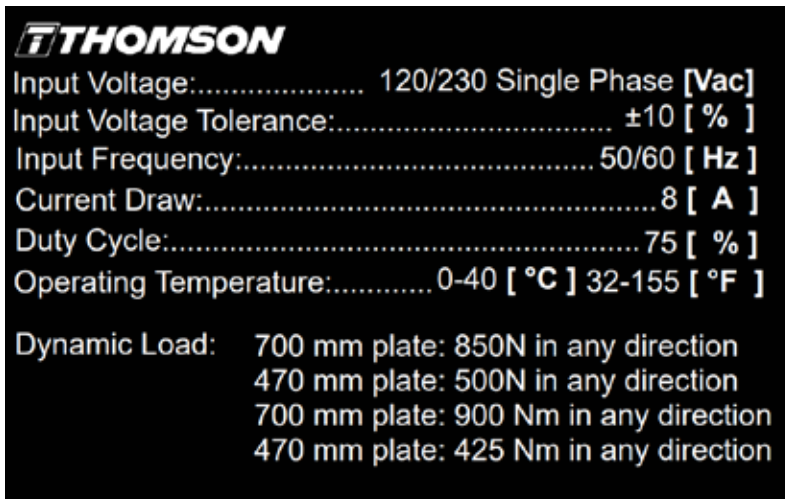

### 3.2 Product model number/ordering key

The model number (which also is the ordering code for your unit) is found on the product label. The below key will describe how your Movotrak CTU unit is configured. This is important to understand in order to safely and successfully install, use and maintain your Movotrak CTU.

Ordering Key						
Position	1	2	3	4	5	6
Example	<b>CTU07</b>	<b>B</b>	<b>R</b>	<b>04500</b>	<b>UR20</b>	<b>A</b>

<p>1. CTU type and size CTU07 = Movotrak CTU size 07 (Movotrak M75 linear unit)</p> <p>2. Drive type B = belt drive</p> <p>3. Motor configuration L = motor on left side R = motor on right side</p> <p>4. Stroke length xxxxx = stroke in millimeters</p> <p>5. Type and size of articulated robot UR05 = Universal Robot UR5e UR10 = Universal Robot UR10e UR16 = Universal Robot UR16e UR20 = Universal Robot UR20 UR30 = Universal Robot UR30</p> <p>6. Base plate A = standard, for 45 mm series extrusion B = for 50 mm series extrusion C = for weldment, M10 holes S = custom holes - contact Thomson</p>
---

## 3.3 List of components and terminology

### 3.3.1 Movotrak CTU assembly

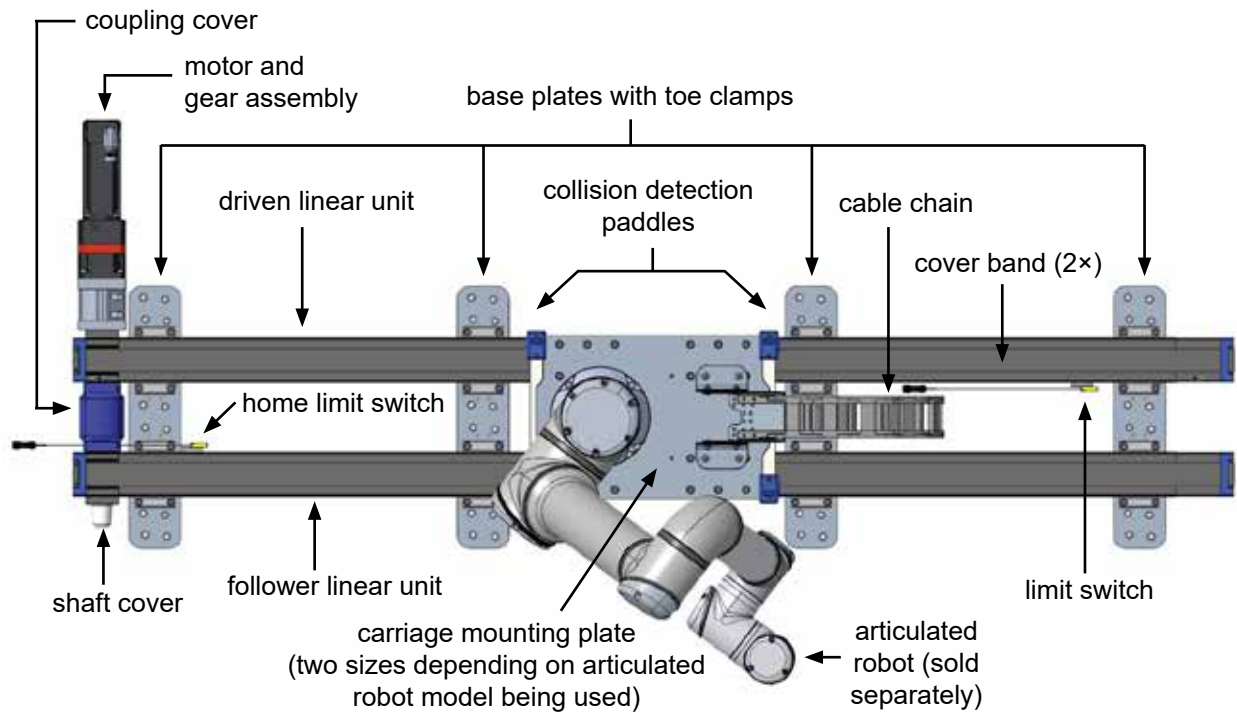

### 3.3.2 Motor and gear assembly

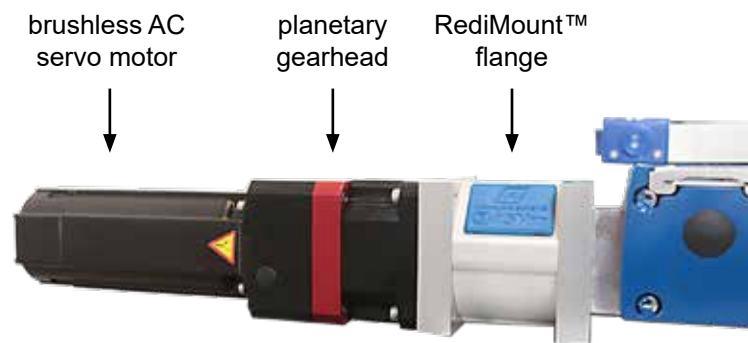

### 3.3.3 Control cabinet



### 3.3.4 Motor cable



### 3.3.5. USB stick



### 3.4 Dimensions

#### 3.4.1 Linear unit assembly

CTU07BxxxxxxUR05(10,16)x

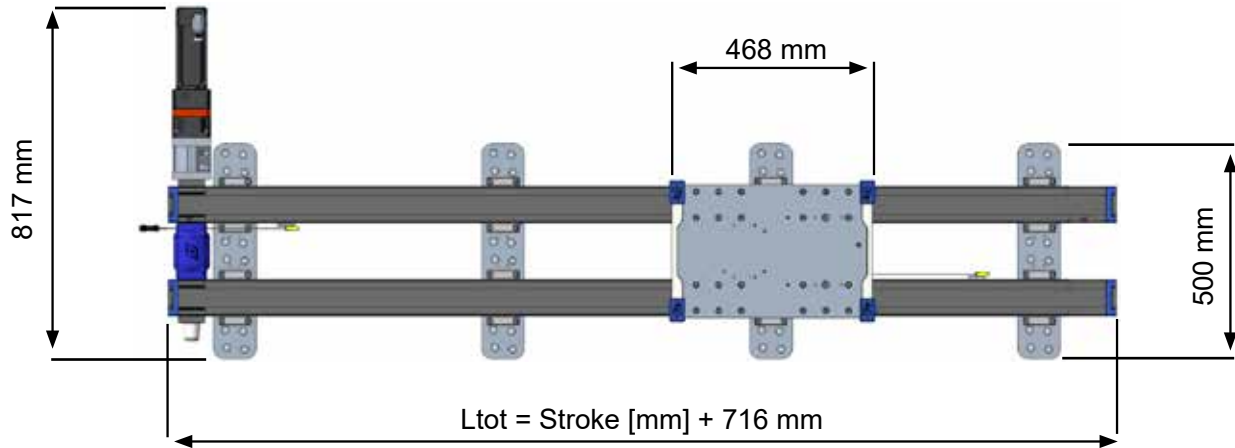

CTU07BxxxxxxUR20(30)x

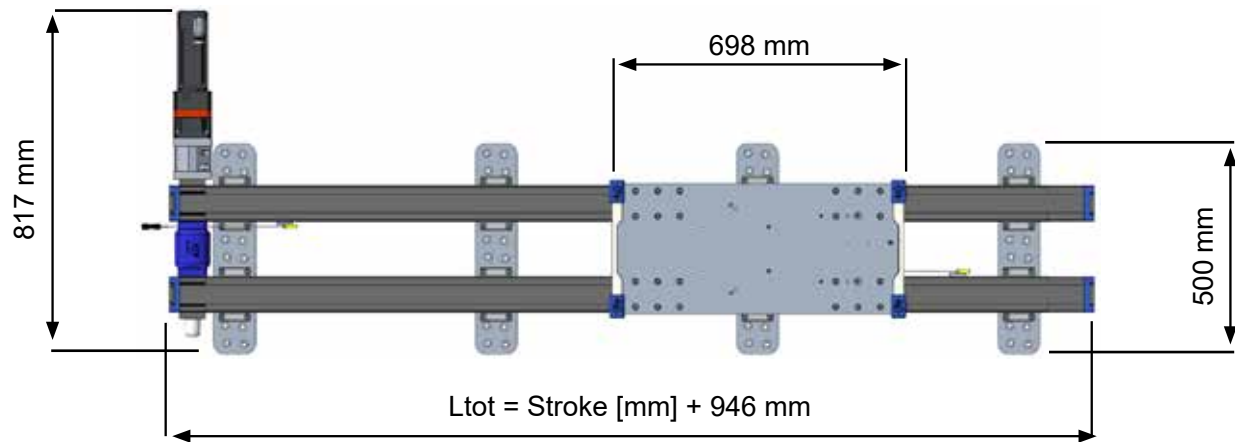

#### 3.4.2 Control cabinet

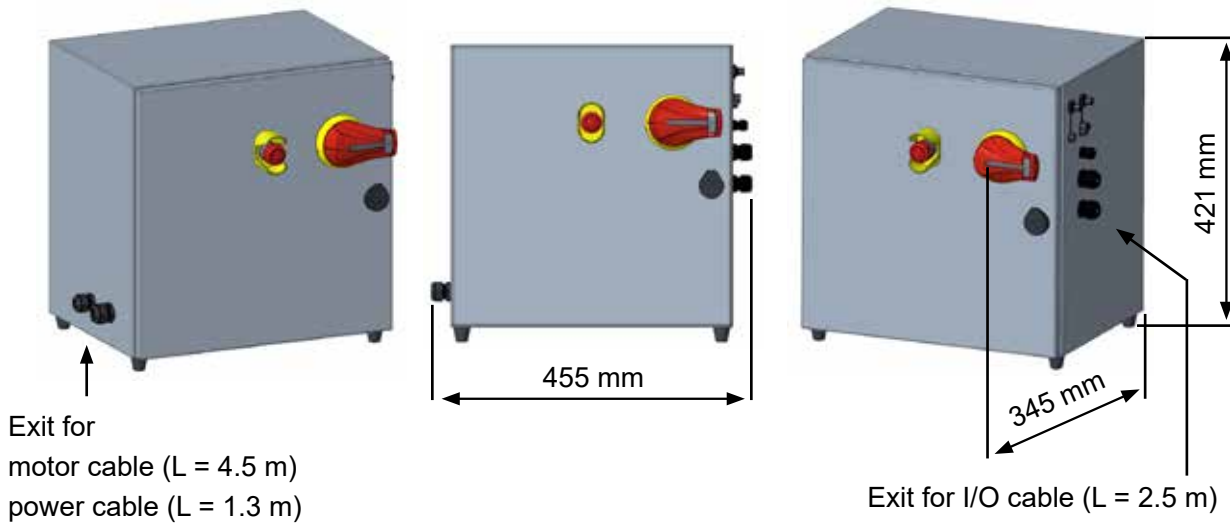

## 4 Mechanical installation

### 4.1 General preparations



Before beginning the installation process, read the complete instructions as there are specifics that may apply to your unique machine which could affect the order of of steps. Planning ahead will make the installation easier, safer and faster. Typical things to source or plan for are:

- how to lift and handle the parts securely and the equipment needed to do so
- tools and fixing elements
- limit switch positioning
- cable routing
- power supply and fuse box connections
- placement of the control cabinet

### 4.2 Tools required

1. Torque wrench for up to at least 40 Nm
2. 5 mm extended reach hex key that fits the torque wrench
3. 6 mm extended reach hex key that fits the torque wrench
4. 2 mm hex key
5. 2.5 mm hex key
6. 5 mm hex key
7. 10 mm combination wrench
8. Large square

1



2



3



4, 5, 6



7



8

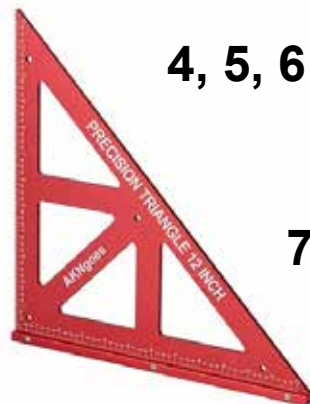

Thomson offers an alignment system consisting of laser alignment equipment, color coded shims and a spreadsheet guide, which greatly simplify the installation of the base plates. Please contact Thomson for more information on and how to order or rent the system.



### 4.3 Moving and lifting

1. Some of the the crates/boxes the Movotrak CTU is shipped in requires a fork lift, pallet jack or other type of lifting device to be moved around.
2. It is recommended to lift the linear units from the shipping crates using lifting straps and power equipment. The linear units can weigh up to 110 kg (for a 10 m stroke unit) and appropriately rated lifting straps must be used. Wrap the strap around the middle of the unit as shown below and lift using power equipment.

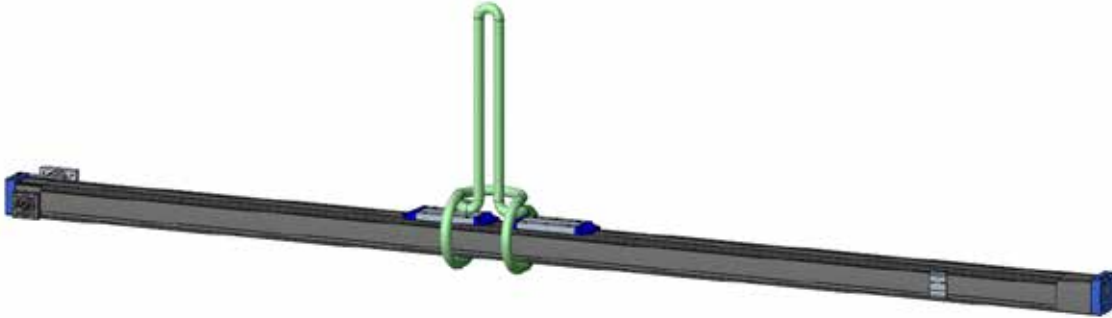

General safety notes on lifting and moving:

- only people that are qualified to operate the lifting equipment in question should do so
- never overload lifting equipment
- never use damaged lifting equipment, hooks or straps
- never walk or stand under a hanging load
- always try to lift objects in their center of gravity
- never leave loads hanging/lifted unattended
- make sure loads are secured before releasing or removing the lifting aid
- place objects carefully on to surfaces
- only place objects on to horizontal and clean surfaces

## 4.4 Mounting

### 4.4.1 Preparation and mounting of the control cabinets and cables

1. The Movotrak control cabinet (a) can sit on a flat surface or be mounted to a vertical surface using the four holes located in the rear.
2. The mounting position must be able to support the weight of the cabinet (25 kg) and must not subject the cabinet to vibrations, dirt, dust or moisture.
3. Make sure the emergency stop button (b) and the main switch (c) can be accessed at the chosen position and that the cabinet door can be opened properly (d).
4. Make sure all of the cables shown on the next page can reach, and are routed to prevent trip hazards and not be subject to wear, abrasion, cutting, chemicals, high heat or other damaging conditions.

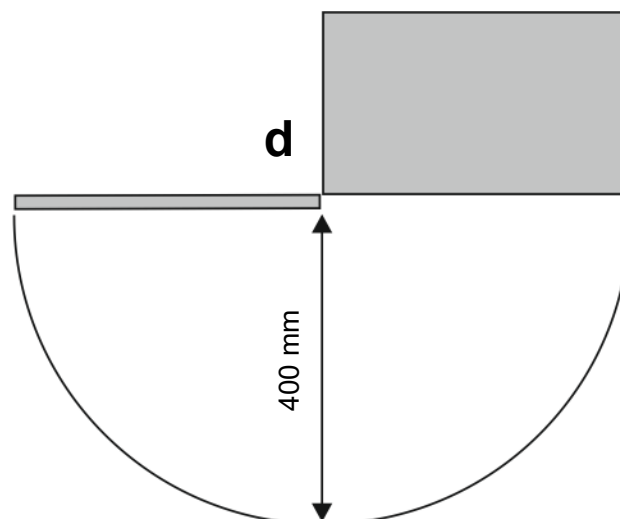
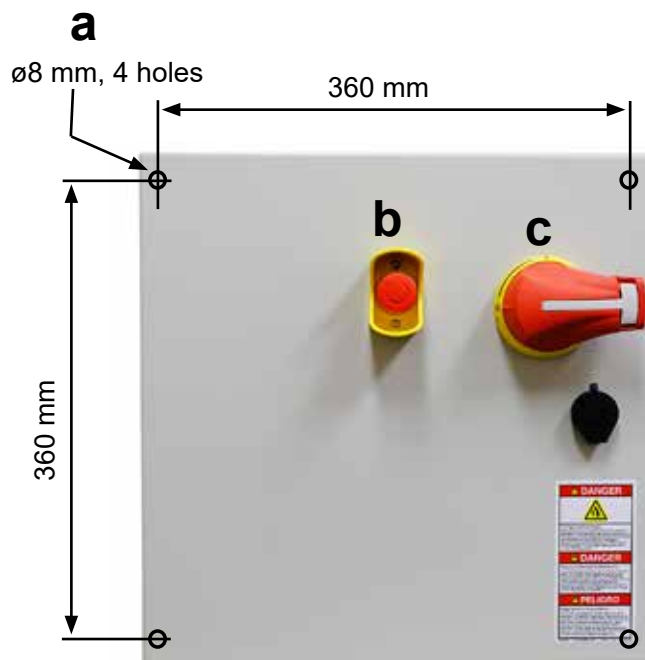

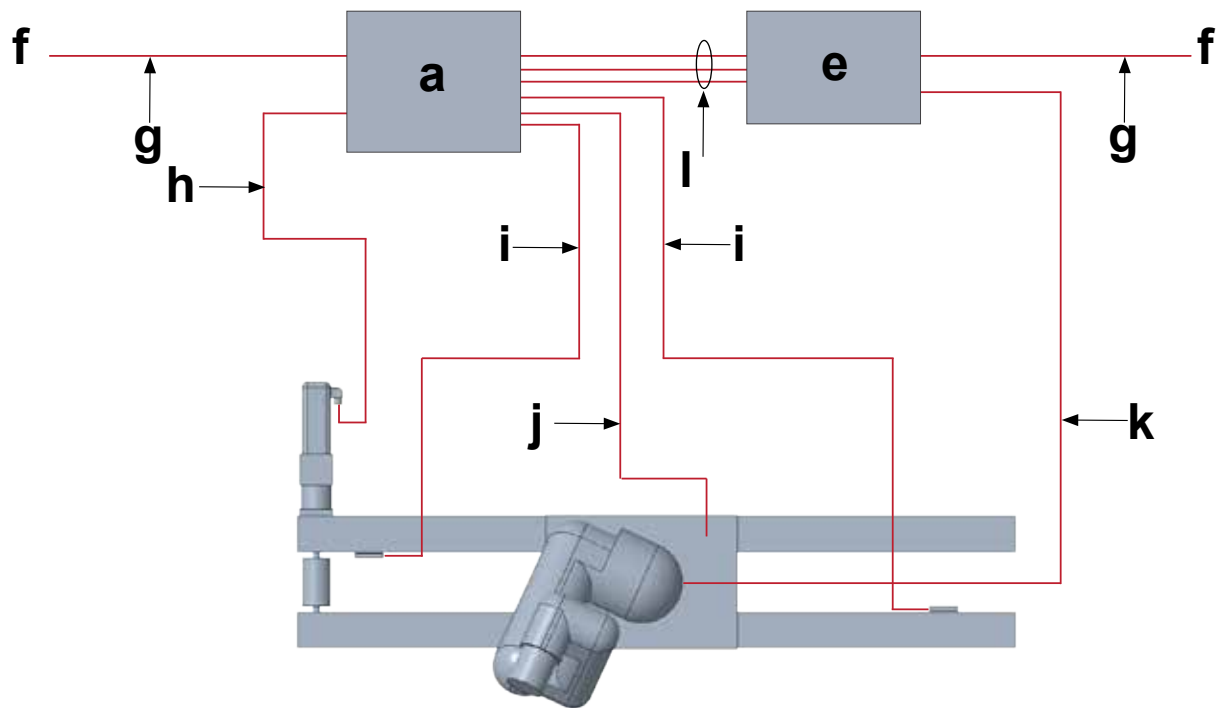

- a. CTU control cabinet
- e. robot control cabinet
- f. AC power source
- g. power cable (1.3 m)
- h. motor cable (4.5 m)
- i. limit and home switch cables (3.4 m and stroke + 3.5 m, up to 7 m max)
- j. load cell cable (stroke + 4.5 m, route through cable chain)
- k. articulated robot cable (route through cable chain)
- l. I/O communication cables (2.5 m)

## 4.4.2 Mechanical mounting preparations

1. Take the Movotrak CTU unit out of the crate and check the parts (also see section 3.3.1). Make sure to lift and handle the parts safely (also see section 4.3).
2. The Movotrak CTU unit comes as standard with base plates (a) that need to be mounted to the linear units (b) and the support surface (c). The plates can, depending on the order, be of different types (d). Which type your unit is shipped with can be determined by looking at the last letter in the product model number (section 3.2) found on the product label (section 3.1).
3. Each mounting point (e) (set of bolts at each end of the base plate no matter bolt size) needs to be able to hold at least 6 kN in all directions and remain rigid enough under maximum load to maintain the necessary flatness and straightness (section 4.4.3).
4. The cable chain (f) will create an overhang as the carriage mounting plate moves towards the support which must be taken in to account when planning the installation. The overhang varies depending on the length of the units and how many cable chain sections are being used. The minimum overhang when the carriage mounting plate is in its the furthest position from the motor end is 65 mm while the maximum is 186 mm.



The customer is responsible for selecting, providing and installing the hardware to secure the mounting feet to the machine frame. The torque requirements on those fasteners depend on the fastener size, type and what they thread into.

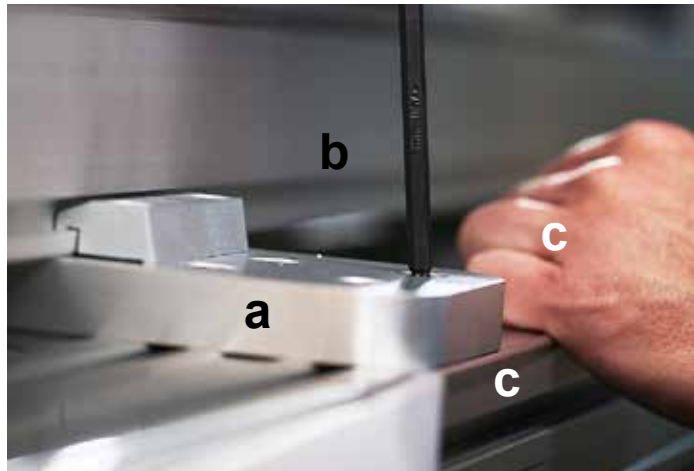

d

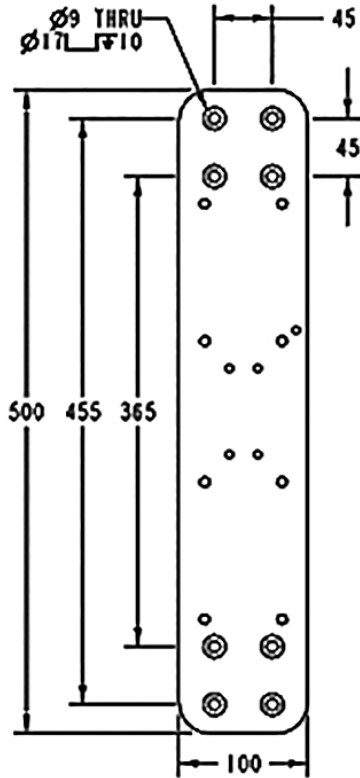

Base plate type A

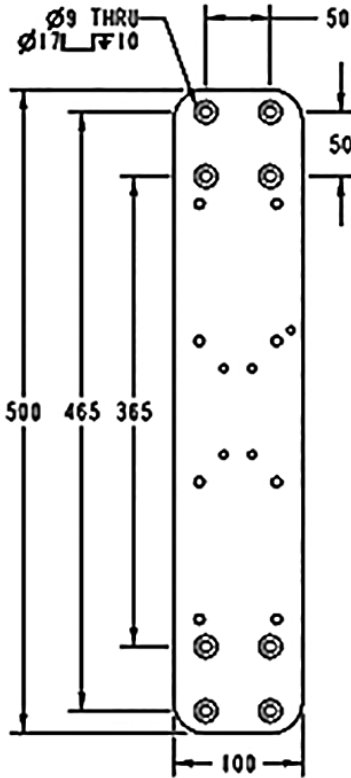

Base plate type B

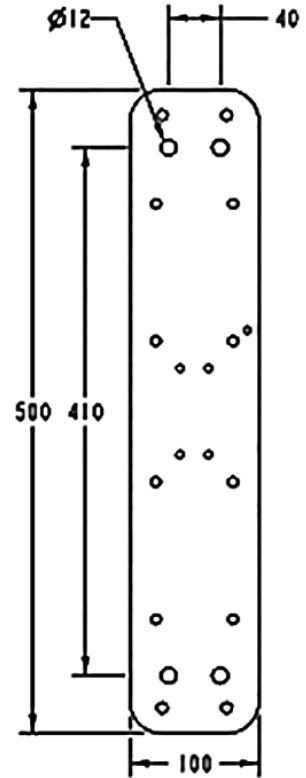

Base plate type C

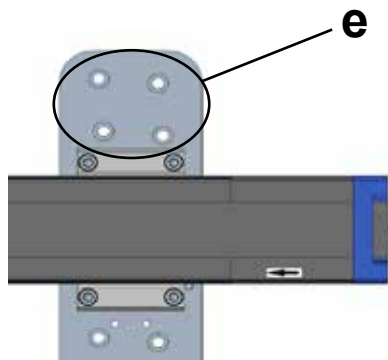

Each mounting point (e) needs to be able to hold at least 6 kN in all directions.

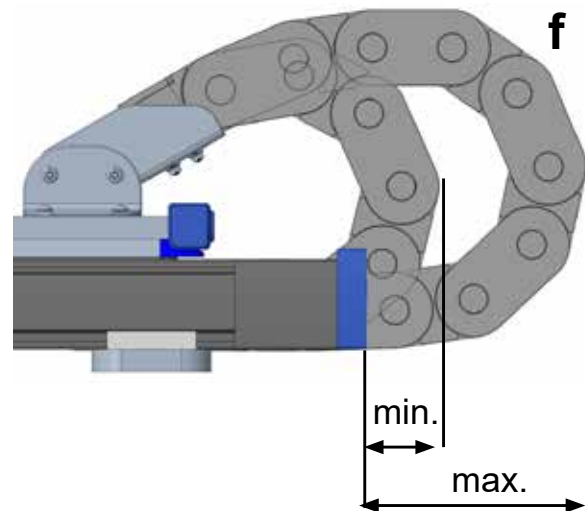

## 4.4.3 Mounting of the linear unit base plates

The plates must be mounted to a flat and stiff surface and not be subjected to any bending or twisting forces. It is recommended that the plates are mounted to a steel weldment. Aluminum extrusion tables can be used but must be designed for stiffness and flatness.

1. The plates is advised to be to be mounted within 0.15 mm flatness and straightness between every set of three consecutive plates though 0.25 mm is acceptable in most installations. Correct flatness can be defined as having the six mounting points (red circles) on top of the plates as all fitting within a box that is 0.25 mm thick (a). The straightness can be defined as having the three banking pins (blue pins in the drawing) in line with each other so that a straight edge against them has a gap of 0.25 mm or less to the center pin (b).
2. The distance between each set of plates will vary depending on the length of the linear units and what the specific installation requires, but the maximum allowed center-to-center distance is 750 mm (c).
3. The first and the last base plate should normally be mounted 20 mm (distance h and f) from the ends of the linear unit profiles. If needed however, the base plates can moved to another position towards to the center of the unit but never further than 100 mm from the end of the linear unit. If repositioning any of the plates the limit switch sensors flags under the carriage plate may interfere with the base plate toe clips and also require repositioning. If the base plates should be moved, then it is easier to reposition these flags prior to mounting the carriage plate. See section 4.3.9 for further information on sensors and how to adjust them.
4. Secure the plates to the mounting surface using your selected fastening method and fasteners while taking the instruction in section 4.4.2 in to account.



Always verify that the limit switch sensors and related flags works properly after the mounting of the system. Also see section 4.3.9.



Thomson offers an alignment system consisting of laser alignment equipment, color coded shims and a spreadsheet guide, which greatly simplify the installation of the base plates. Please contact Thomson for more information on and how to order the system.

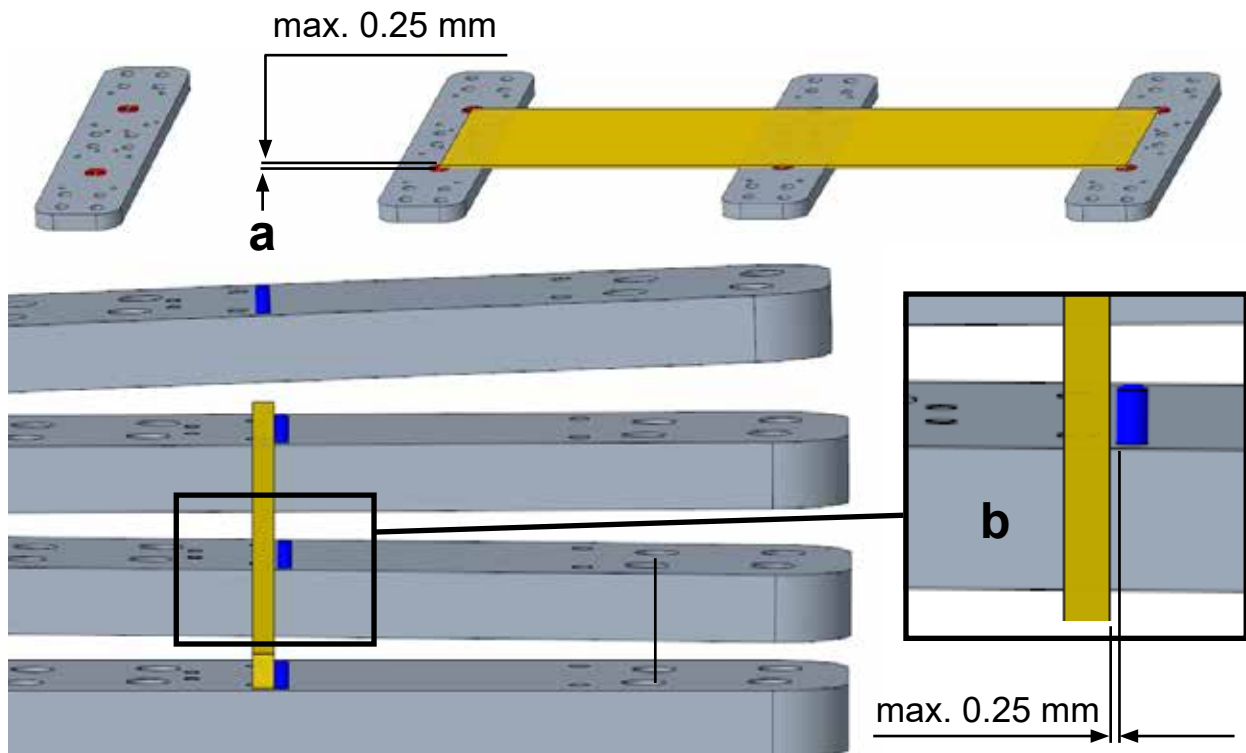

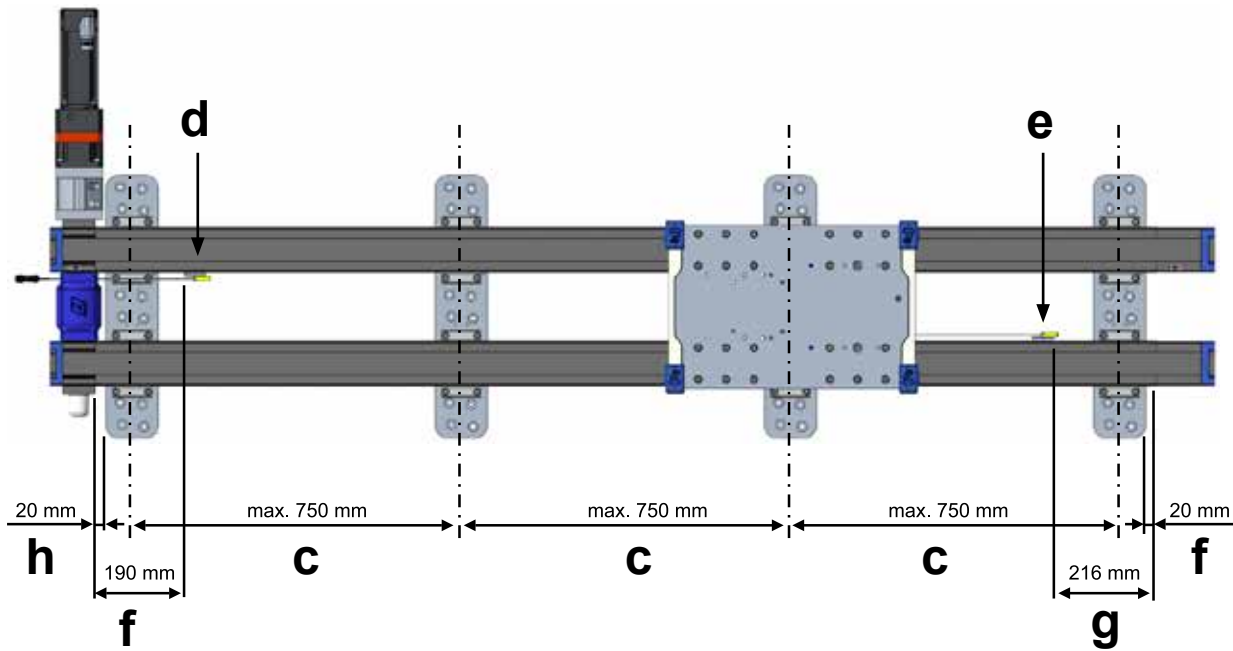

#### 4.3.4 Mounting the first (driven) linear unit to the base plates

1. Place the linear unit with the motor flange (a) on the base plates (b) so that it is in contact with all the banking pins (c).
2. Position the linear unit profile ends with the intended spacing to the first and the last base plate (d). This is typically 20 mm as shown in section 4.4.3.
3. Place four socket head cap screws (M8 × 20) through the toe clamps on each side of the linear unit and into the holes in base plates (e). Tighten to 15 Nm. Verify the linear unit is resting flush against the pins at each plate then tighten all screws to 25 Nm.



Make sure it will be possible to route all the robot cables and if necessary set cables in place prior installing the driven slide as the robot cable connector may not fit between the slide and machine frame.

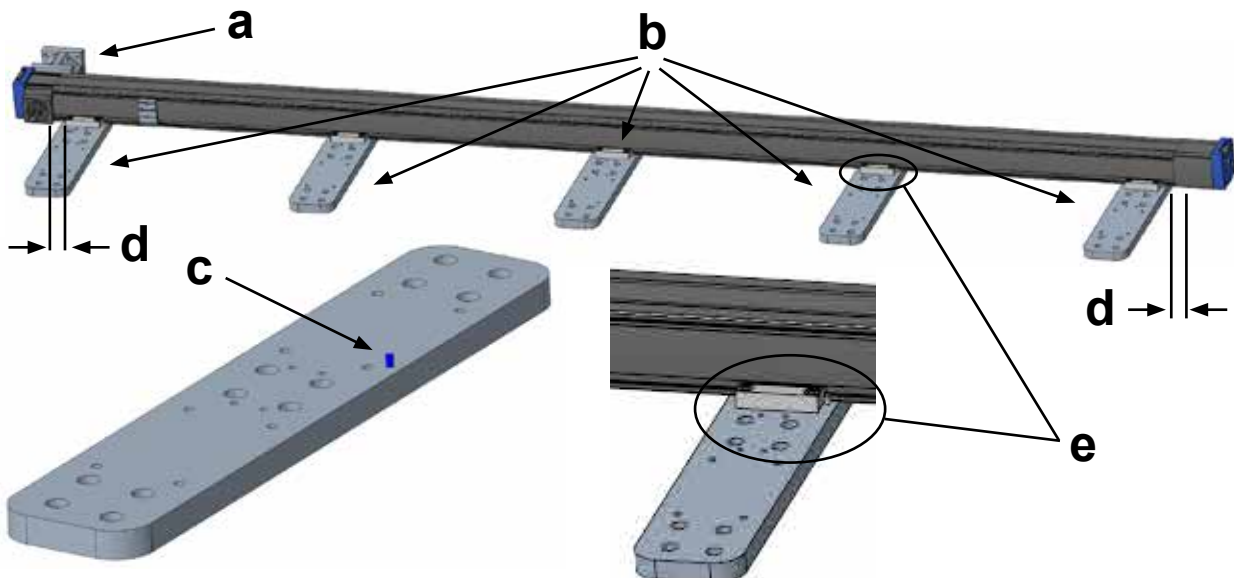

## 4.3.5 Preparing the coupling and shafts

1. Loosen the coupling screws (a) with a M6 hex key.
2. Clean the inside of the coupling bores (b) with a cloth to remove any debris or oil. If needed, use a residue free cleaner.
3. Clean the outside of the drive shafts (c) on both linear units with a cloth to remove any debris or oil. If needed, use a residue free cleaner.
4. Remove any key from the drive shafts if the linear units came with one.

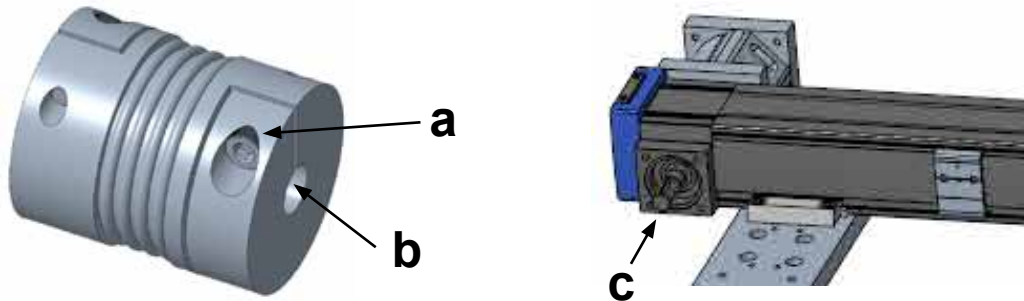

## 4.3.6 Placing the second (follower) linear unit and installing the carriage mounting plate

1. Set the follower unit in place with the drive shaft in the coupling. Ensure the coupling is not restricting the positioning of the slide.
2. Position the carriages of both slides near the idle end as shown and place the mounting plate (a) on them so that the screw holes line up.
3. Install one of the flat head screws (M8 × 25) in the counter sink hole of the driven linear unit (b) and tighten to 10 Nm.
4. Install six socket head cap screws (M8 × 20) in the holes on the driven unit closest to the motor end (c) and tighten to 15 Nm.
5. Install the remaining five socket head cap screws (M8 × 20) in the driven unit around the flat head screw (d) and tighten to 15 Nm.
6. Install the flat head screw (M8 × 25) in the indicated hole on the follower unit (e) and tighten to 10 Nm.
7. The follower slide should be free to shift along its long axis. Use the square (f) to align the drive ends as shown to ensure long life of the bearings in the drive stations.



Do not push the carriage plate with more than 200 N (50 lb) of force or it may damage the sensors. If the carriage will not move with less than this force then check for obstructions or binding.

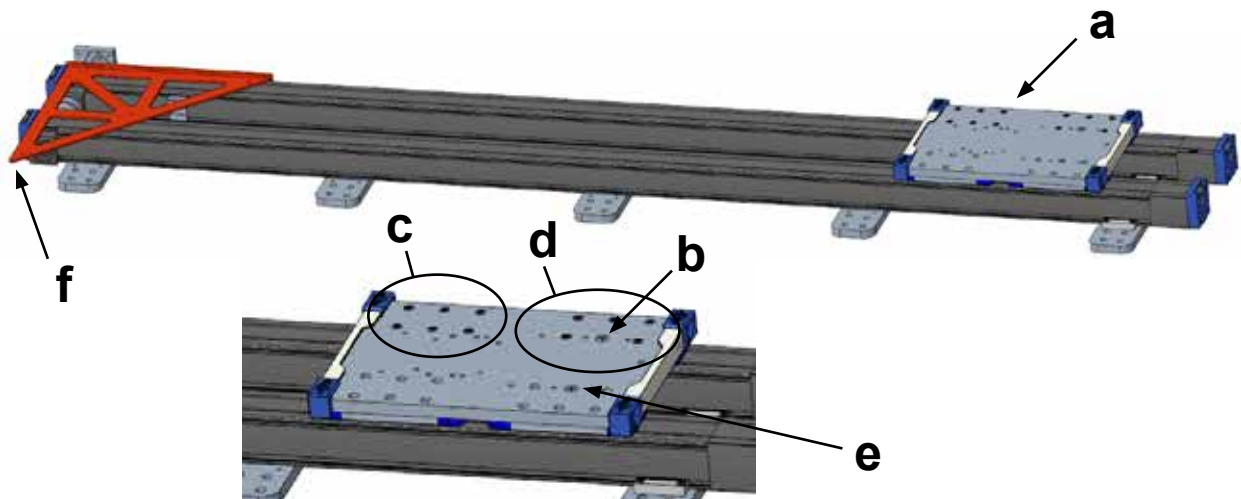

#### 4.3.7 Securing the second linear slide with toe clips

1. Install four socket head cap screws (M8 × 20) through toe clamps and into the base plate furthest away from the motor end as indicated (a). Tighten to 15 Nm.
2. Move the carriage plate to just past the second base plate (b) and install the toe clamps and tighten to 15 Nm.
3. Repeat this process for all the base plates (c and d) except for the one closest to the driven end of the linear units (e).

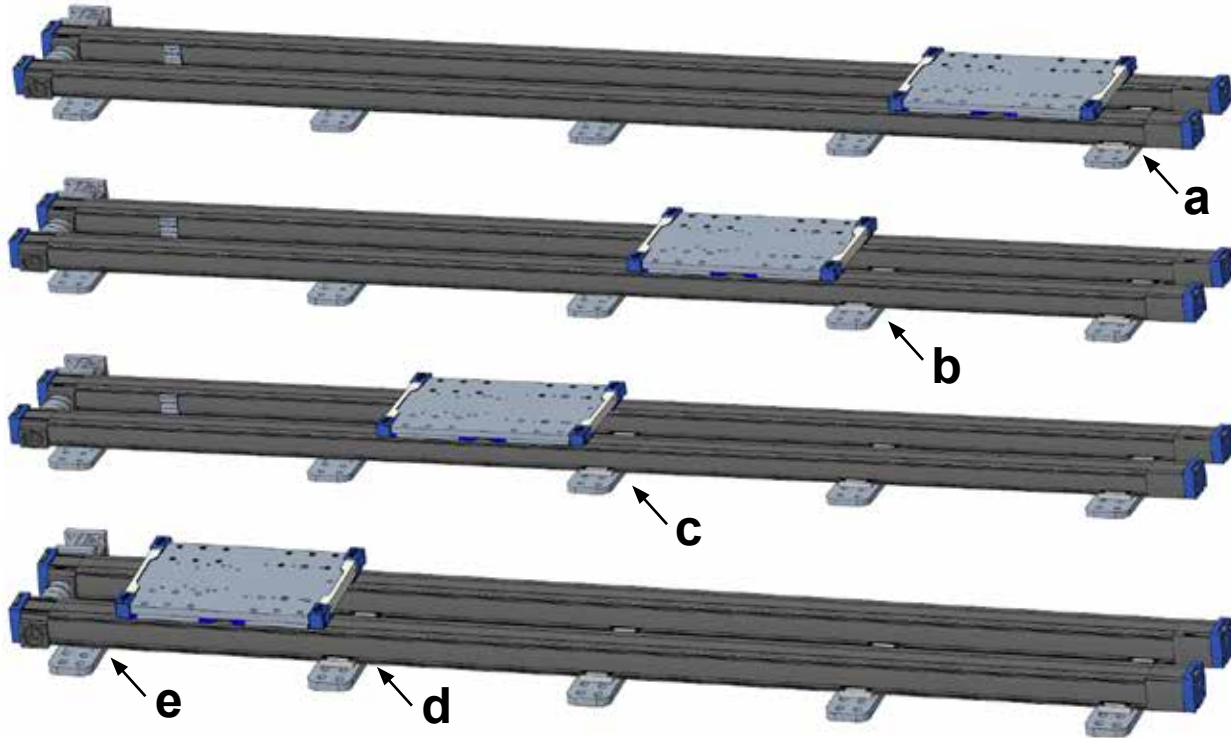

#### 4.3.8 Final carriage mounting plate and toe clips installation

1. Move the carriage plate (a) to between any two base plates that have toe clips installed (b).
2. Install the eleven socket head cap screws (M8 × 20) that secure the carriage plate to the linear unit carriages (c). Tighten to 15 Nm.
3. Move the carriage plate close to the driven end (d) and install the toe clips on the remaining base plate (e). Tighten to 15 Nm.
4. Tighten all the toe clip screws and socket head cap screws in the carriage plate to 25 Nm.

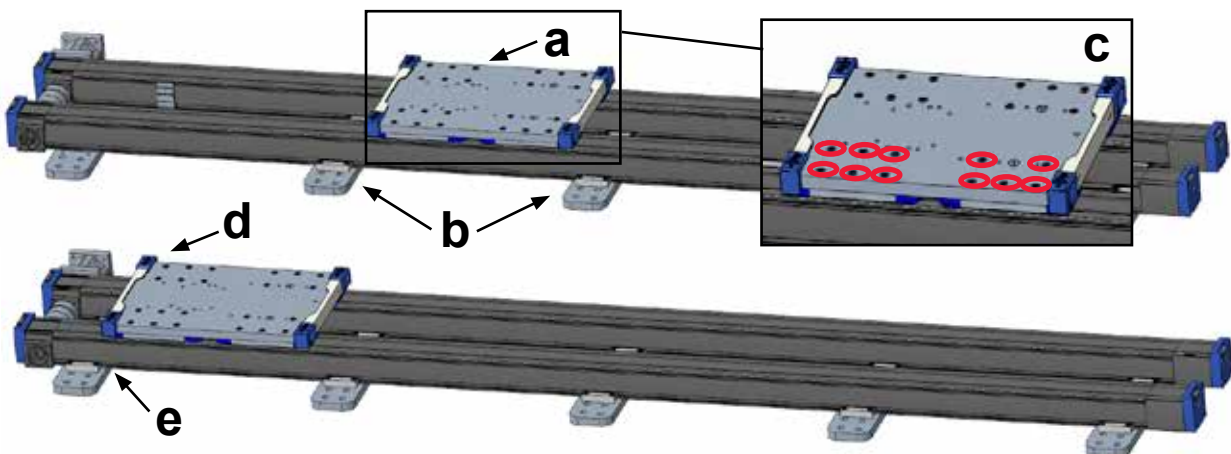

## 4.3.9 Final coupling tightening, coupling cover and shaft cover installation

1. Tighten the coupling screws to 40 Nm (a).
2. Snap the two halves of the coupling cover into place (b).
3. Place the shaft cover over the exposed shaft of the follower unit and secure with four button head screws (M16 × 6).

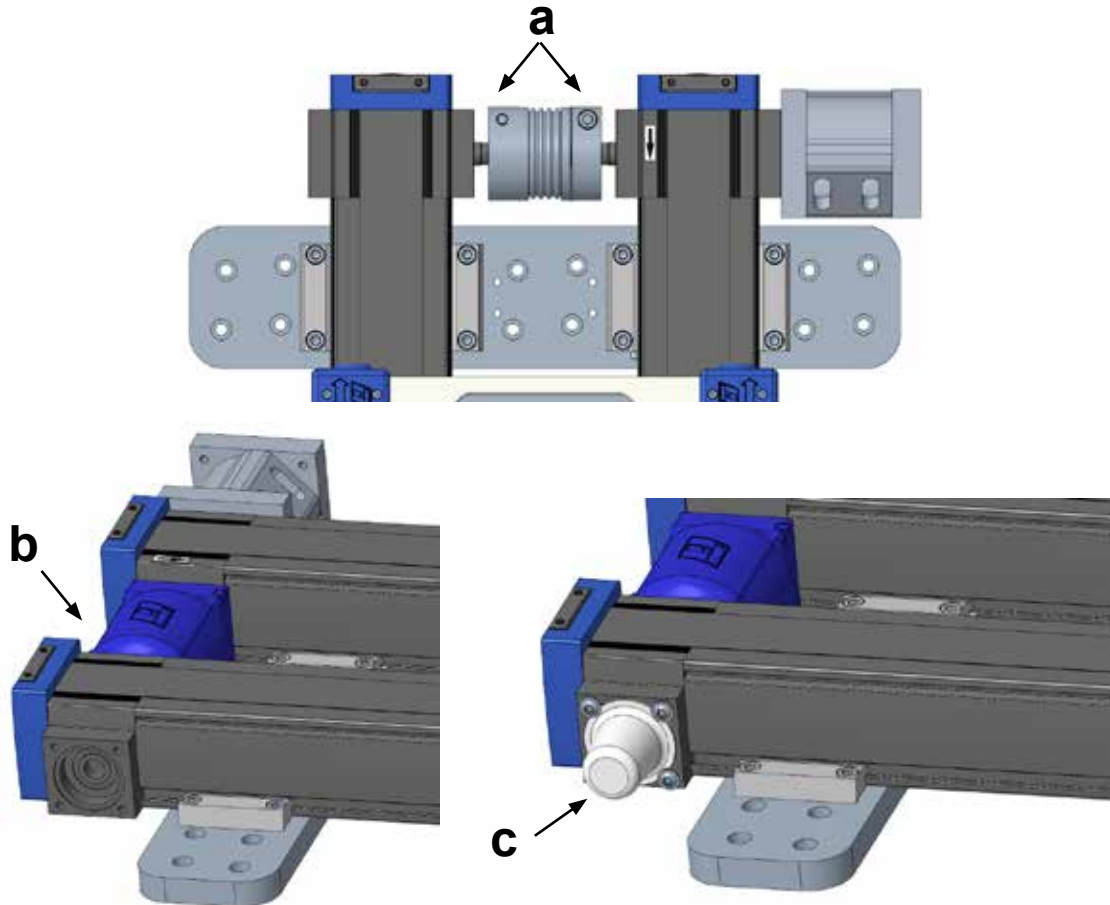

## 4.3.10 Mounting of and setting up the limit switch sensors

The linear units ship with the home (a) and end-of-stroke (b) limit switch bracket installed but the sensors need to be mounted to the brackets. The actual sensors are interchangeable and vary only by location. Depending on the machine setup and where the control cabinet is located, it may be necessary to swap the switches or change which way the cable faces.

Each sensor is tripped with its own flag (c and d) on the underside of the carriage plate. The sensors are positioned to give the ordered stroke length between the sensors while giving a 50 mm of safety distance between each sensor and the actual hardstop indicated by the over travel arrow sticker in the ends. If the base plates for a particular installation do not follow the typical end position of 20 mm to end of the linear unit profiles, the switch bracket may interfere with toe clips and necessitate moving the flag(s) on the carriage plate. Alternate holes (e) for mounting the flags are provided. It is much easier to move the flag prior to mounting the carriage plate. If moving a flag, ensure the 180 mm dimension and tighten the M5 flanged button head cap screws to 5 Nm. Also see section 4.4.2.

1. The home switch sensor (closest to the driven end) has the shorter cable and the cable will exit towards the motor end. To change the cable direction, remove the two socket head cap M3 screws (f) holding it to the bracket, flip the direction and reinstall the screws.

2. To reposition the bracket, loosen the two set screws in the top of the bracket (g) using a M2 hex key, slide the bracket to the new position and tighten the screws enough to hold it in place. If repositioning, do not tighten the set screws until verifying the position using the flag on the carriage to confirm the location of the switch (point 4).
3. Repeat with the sensor on the undriven end if necessary.
4. Roughly verify the position of the sensor relative to the sticker on the end of the linear unit before start up. Position the carriage so that the end of the carriage plate is 50 mm from the over travel arrow sticker (h). The flag should now cover half of the sensor area (i).
5. After the system is powered up and prior to homing the system, use the Free Drive function to move the system to each end of the linear unit to make sure that each sensor stops the system correctly. Also verify the 50 mm of overtravel room in each end after the stop and then snug the setscrews to lock the sensor bracket in place.



Always rehome the system if the limit switch sensors are moved.

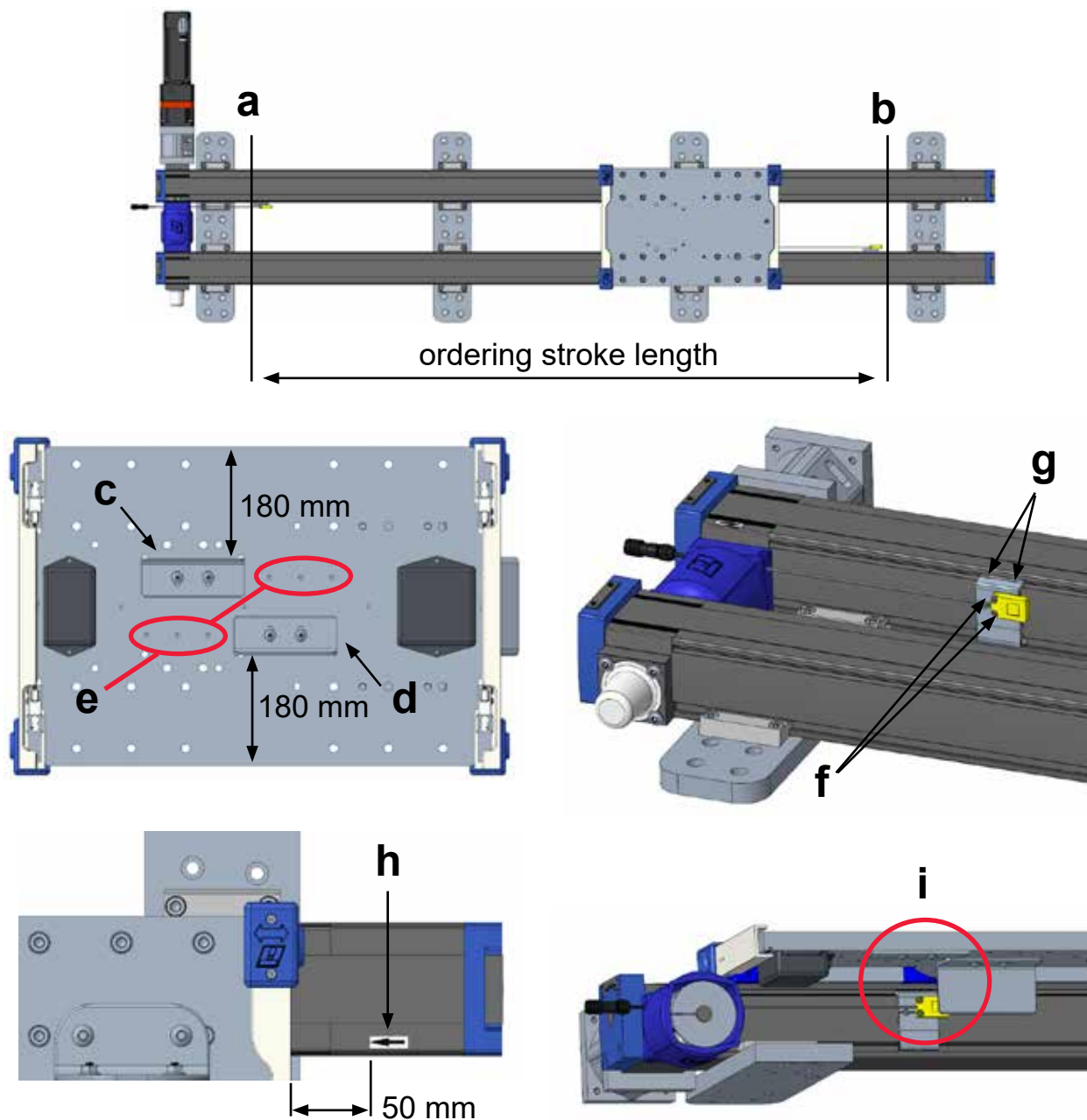

## 4.3.11 Cable chain installation

1. Orient the cable chain such that the metal cable holder on each end (a and b) can sit as shown in the pictures.
2. If the system has an odd number of base plates, mount the end to the middle plate. If the system has an even number of plates, mount to the middle plate closest to the drive end. Install the fixed end to the appropriate base plate using four socket head cap screws (M6 × 18). Do not tighten screws yet.
3. Move the carriage plate to the far undriven end of the system until it hits the hardstop. Place the moving end of the cable tray in the bracket and ensure it is free to flex and sit in the bracket.
4. Mount the cable chain bracket assembly to the carriage plate (b) using four button head screws (M8 × 16). Do not tighten screws yet.
5. Mount the moving end of the cable chain to the carriage plate chain bracket (d) using four socket head cap screws (M6 × 18) and flanged nuts. Do not tighten yet.
6. If there is excess cable chain, pairs of links may be removed to shorten it. Use a small flathead screw driver to pry up the tabs of the cross bars and to disassemble links. Use pliers to snap cross bars back into place once the appropriate number of link pairs are removed.
7. Ensure the cable chain sits evenly between the toe clips then tighten fasteners to:  
M6 SHCS = 10 Nm  
M8 BHCS = 15 Nm
8. Feed the robot cable, load cell cable and any other required cables or hoses through the cable chain.
9. Secure the ends of cables to the holders at each end of the chain using zip ties (not included).



Only use cables and hoses intended for cable chain use and make sure they can handle the bending radius of the chain.

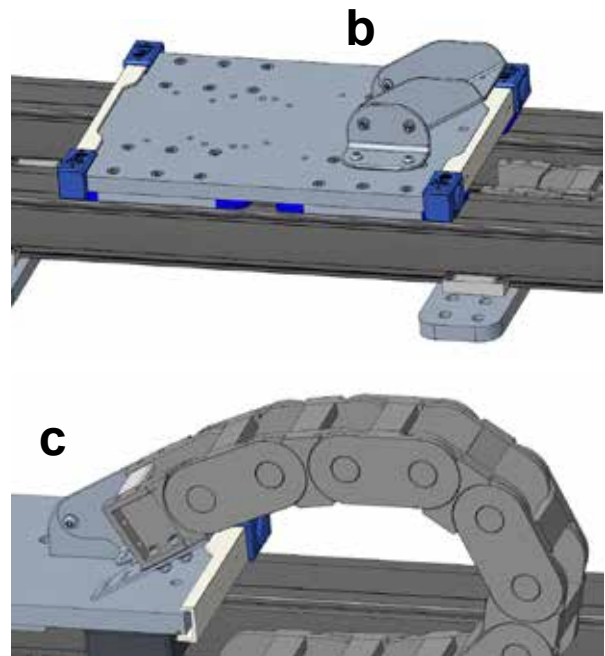
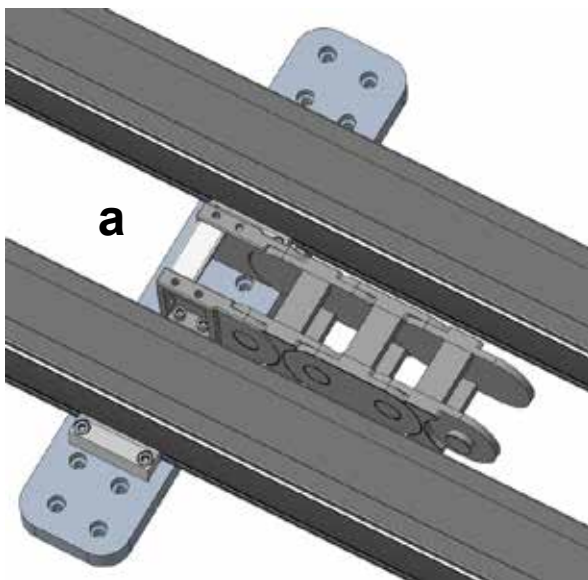

#### 4.3.12 Mounting the motor and gearhead assembly

1. The gearhead of the Movotrak CTU system interfaces using a coupling with two hubs (a) on each side of an elastomer insert (b). The hubs are mounted on the shafts at the factory.
2. Place the elastomer insert into the hub on the linear unit shaft and insert the motor (c) into the motor mount (d) being sure the cable connector (e) faces the way that works best for your machine.
3. Insert the four socket head cap screws (f) (M6 × 18) through the motor flange (g) and into the adapter flange (h) of the motor mount (c). Snug all four in turn to pull the pilot of the gearhead into the adapter flange evenly.
4. Tighten the screws to 7 Nm.
5. Use a 5 mm hex key and check that the hub screws (i) on each hub are tightened to 15 Nm.
6. Press the blue cap (j) into place to cover the screw access slots.

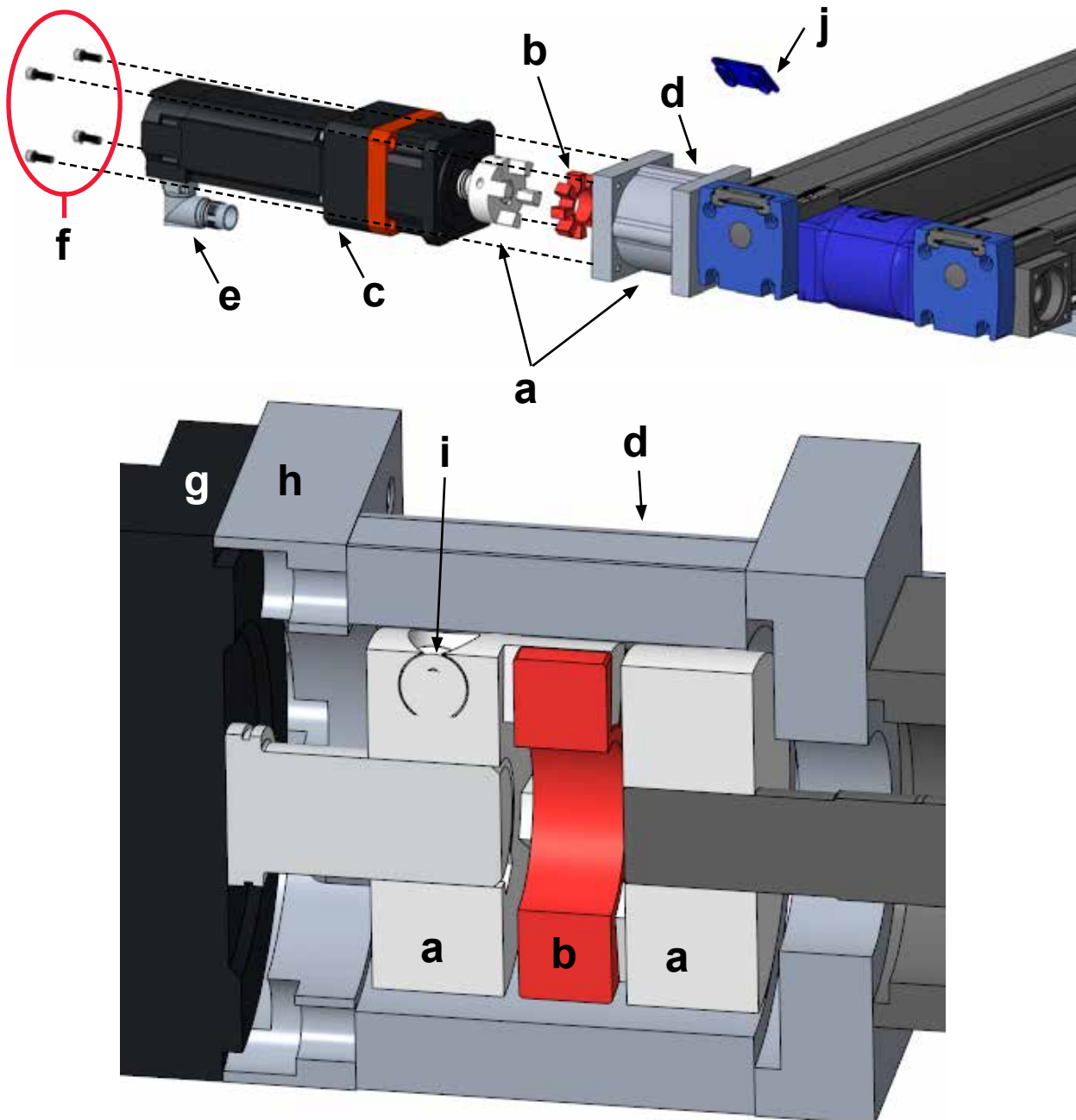

## 5. Electrical installation and software setup

### 5.1 Connecting the Movotrak CTU to the Universal Robots control system

#### 5.1.1 Cable connections

##### On the Movotrak CTU control cabinet

Connect the motor, power and sensor cables to the Movotrak CTU as described below.

1. Connect the motor cable (orange cable) to the motor. Lineup the pins, firmly push the connectors together and then twist the sleeve to lock the connector in place.
2. The power cable is supplied with Type B plug for use with grounded 120 Vac outlets in North America. Installing the Movotrak CTU system in other countries/regions may require use of an adapter or replacement of the plug.
3. Connect the power cable to a 120/230 Vac,  $\pm 10\%$ , 50/60 Hz, 10 A circuit.
4. Connect the home and end-of-stroke limit switch sensors to the connectors on the right side of the control cabinet. They are labelled "Home" and "Limit". The home switch is the sensor located nearest the motor end of the Movotrak CTU. Line up the connector and gently push the connectors until they click into place.
5. Connect the "Stop Paddle" cable to the cabinet connector labelled "Load Cell".



Make sure the control cabinet and the power supply cable is properly connected to PE (protective earth) according to the rules and regulations in the country/region in question.

##### On the Universal Robots control cabinet

Remove the bottom panel and pull through the I/O cable wire bundle from the Movotrak CTU control box. Connect as described below.

1. Connect the protective earth wire bundle to the ground nut located on the base of the cabinet.
2. Connect the prewired safety outputs connector (yellow connector, red lettering) to the Universal Robots safety outputs (a).
3. Connect the prewired configurable outputs connector (yellow connector, black lettering) to the Universal Robots digital outputs (b).
4. Connect the prewired digital output connector (gray connector, black lettering) to the Universal Robots digital outputs (c).
5. Connect the blue Ethernet cable connector to the Ethernet port (d).

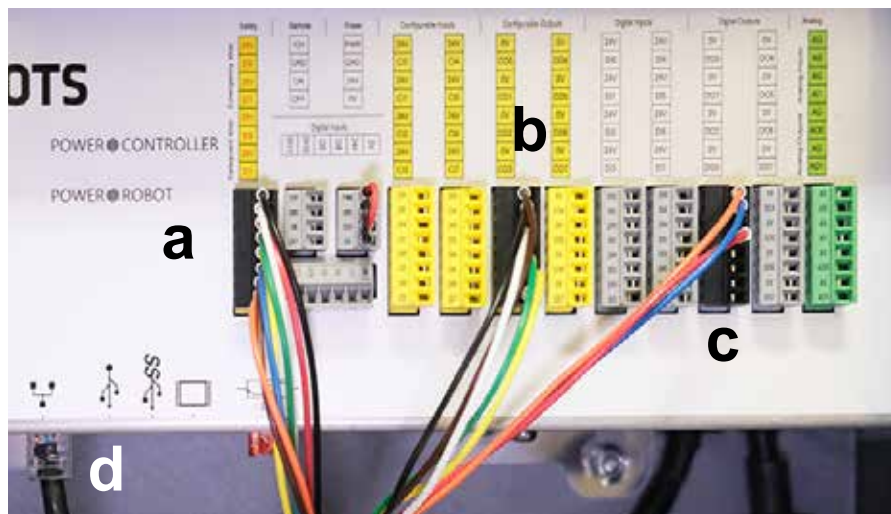

### 5.1.2 Setup of the safety I/Os

To be able to activate the Movotrak CTU, the safety and general I/Os must be configured correctly in the Universal Robots environment using the teach pendant.

1. On the “Installation” tab, select “Safety” from the menu on the left side. Navigate to “I/O”. On the “Safety I/O” tab, assign outputs as below.
2. Assign “config\_out(0), config\_out(1)” to: System Emergency Stop  
Assign “config\_out(2), config\_out(3)” to: Robot Not Stopping (Safeguard Stop)

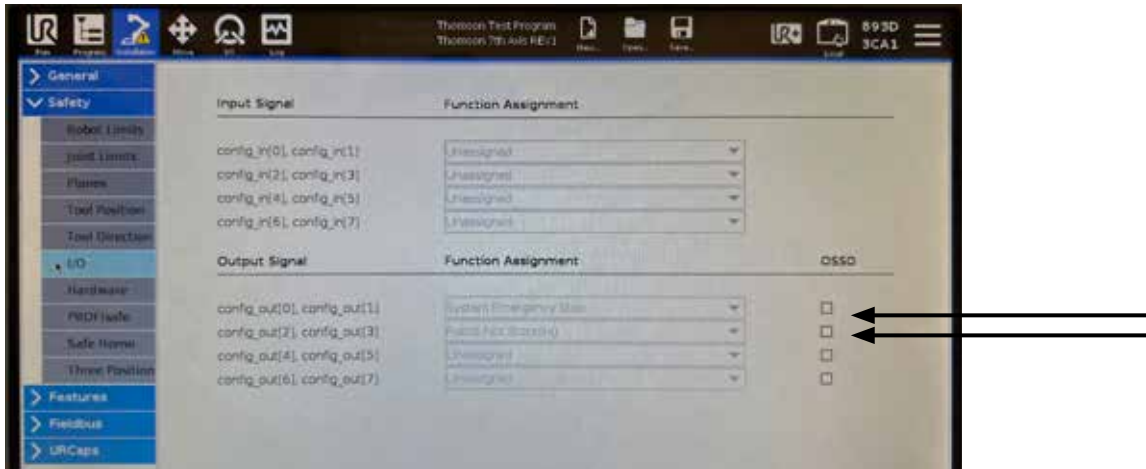

### 5.1.3 Setup of the general digital I/Os

In the “Installation” tab, navigate to the “General” menu on the left hand side and select “I/O Setup”.

On the “General I/O” tab, assign outputs as seen in the image:

1. Assign “DO0” to: “Low on unscheduled stop, otherwise High”.
2. When complete, DO0 should show “Prog abort” has been assigned.
3. Assign “DO1” to: “High when running, low when stopped”.
4. When complete, DO1 should show “Prog-Running” has been assigned

Note: If the I/O above are in use by other third-party URCaps, other I/O ports of the same type can be used. Adjust the I/O assignments accordingly in the Installation tab. In order for proper communication of emergency and safeguard stops between the Universal Robot control and the Movotrak CTU motor drive, this install setup must be used for all programs.

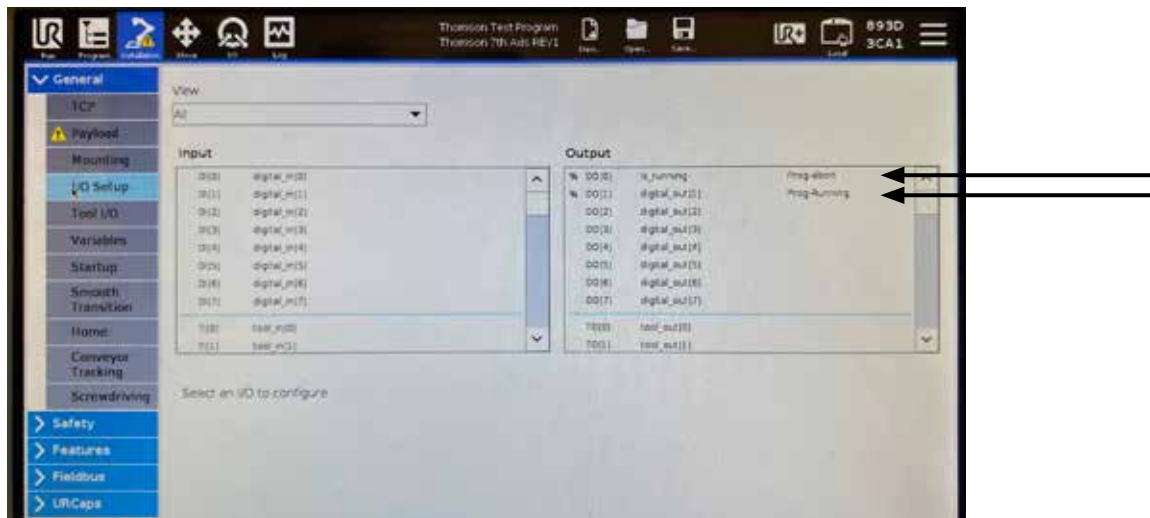

## 5.1.4 Installation of URCaps

To install Thomson URCaps, follow these steps:

1. Click on the hamburger menu in the top right corner (a).
2. Click “Settings” (b).
3. Go to “System” (c), select “URCaps” (d) and press “+” (e).
4. Insert the Movotrak CTU USB drive into the USB port in the programming pendant, choose URCaps file from the USB drive and press “Restart”.

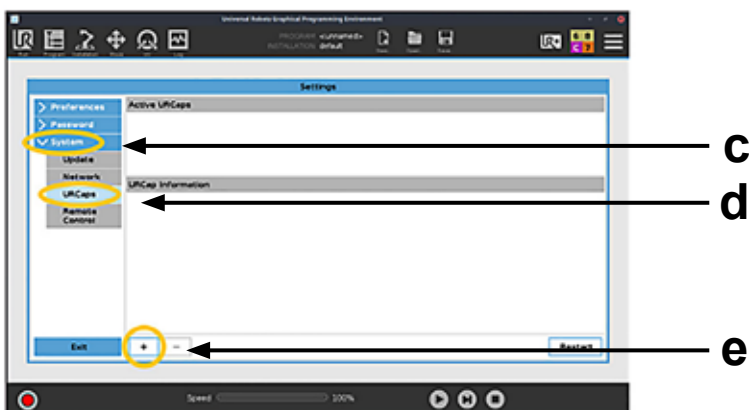
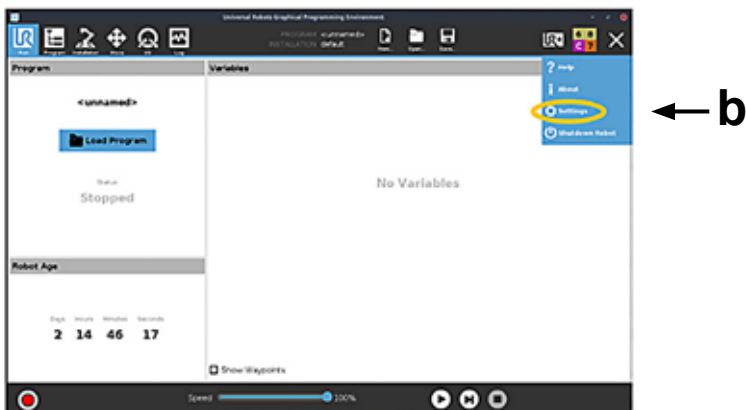

## 5.2 Basic setup

### 5.2.1 General information

The system requires a basic setup procedure which includes:

1. Entering of the motor drive IP address into the control system.
2. Setting up the home position (zero position) of the articulated robot.
3. Performing a homing move sequence for both the articulated robot and the Movotrak CTU 7<sup>th</sup> axis. (homing will be needed after each time power is removed from the overall system when all axes will move to home at a designated speed).
4. Determining the available stroke of the Movotrak CTU 7<sup>th</sup> axis by letting it move between the home sensor on the motor side and the support side sensor.
5. Setting up speed, acceleration and other movement parameters.
6. Testing of the system and adjustment of the collision protection sensitivity.



Be careful when setting up the system and make sure only qualified personnel necessary for the process are present.

### 5.2.2 Entering the IP address of the motor drive and setting up the Universal Robot Modbus

1. Open the Movotrak CTU control cabinet.
2. The small drive display will scroll through status information, including the IP address (a).
3. Enter the IP address into the accompanying URCaps field (b) in the teach pendant.
4. Then click on the hamburger menu in (c) in the top right corner and chose “Settings”.
5. Go to “System” (d), and choose “Network” (e) to create a “Static Address” (f). The “IP address” field (g) should have the same address entered in step 3 above, but with the last digit changed. Eg, if the motor drive was assigned IP address 169.254.237.41, then enter 169.254.237.42 in this field.



To perform the above the cabinet must be opened with power on. Only personnel qualified to work on energized equipment should perform this task and nothing inside the cabinet should be touched during the operation.

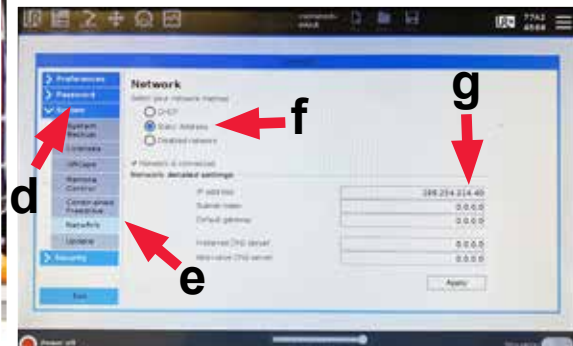
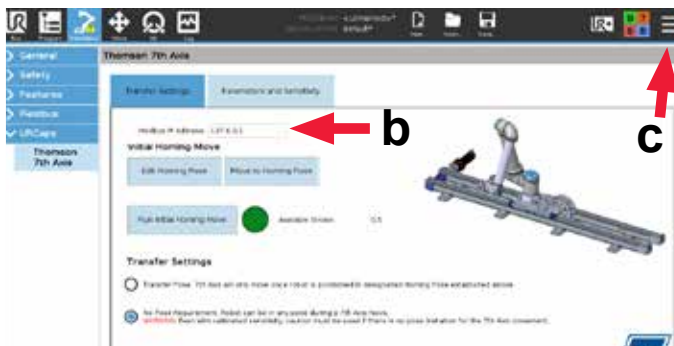

## 5.2.3 Homing of the articulated robot

Perform a homing sequence for the articulated robot by pressing “Move Robot into Homing Pose”.

## 5.2.4 Move the Movotrak CTU 7<sup>th</sup> axis to its home position and determine the max. stroke

1. Go back to “URCaps” and select and hold “Move Robot into Homing Pose” (a) to properly position the robot.
2. Next select and hold the “Move 7th Axis through Homing Process”. The 7<sup>th</sup> axis will begin moving to the motor side limit switch. On the first homing sequence, the 7<sup>th</sup> axis will reach the motor side limit switch and then travel to the opposite limit switch. This will establish the “Available Stroke” for the 7<sup>th</sup> axis and also establish software limits to accompany the physical limit switches. On subsequent homing moves, the 7<sup>th</sup> axis will only move to the motor side switch. The “Move 7th Axis through Homing Process” button must be held until the homing move and if needed, the available stroke move, are completed.
3. On the “Transfer Settings” tab, the homing indicator light will now be green (c). If the light is not green, repeat the homing process and ensure that the full homing move is completed.

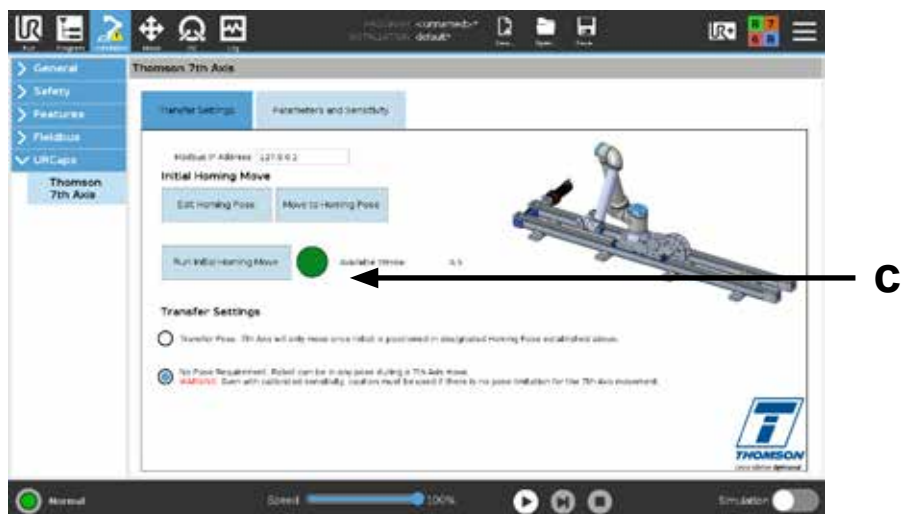
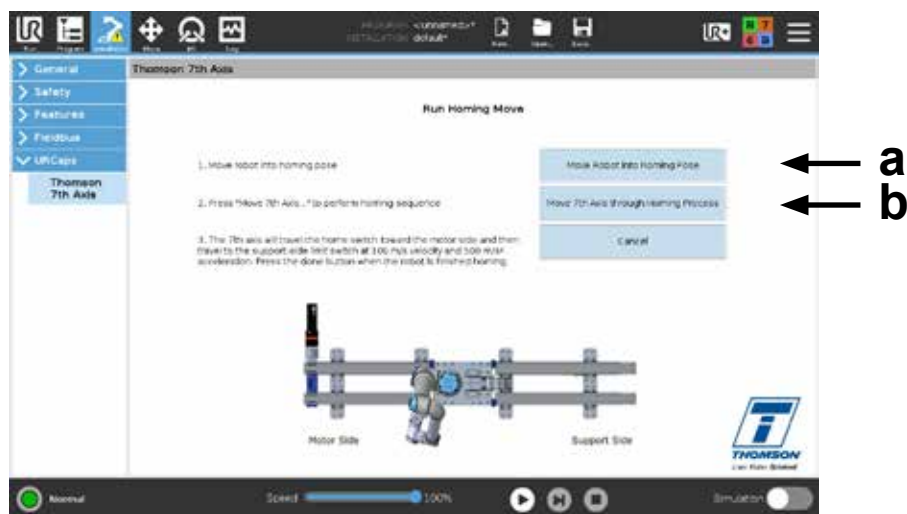

### 5.2.5 Transfer pose requirements

Select from the following options for when the Movotrak CTU 7<sup>th</sup> axis is allowed to move:

1. Transfer Pose. The 7<sup>th</sup> axis will only move once the articulated robot is positioned in the designated homing position established earlier (section 5.2.3).
2. No Pose Requirement. The articulated robot can be in any position during a 7<sup>th</sup> axis move.



Even with calibrated collision sensitivity, caution must be used if there is no pose limitation for 7<sup>th</sup> axis movement. The user is responsible for a risk analysis for their application.

## 5.3 Setting up move parameters and sensitivity

The following steps will let you adjust the default speed and acceleration/deceleration rates as well as tune the motor and adjust the collision protection sensitivity.



Be careful when setting up the system and make sure only qualified personnel necessary for the process are present.

### 5.3.1 Default movement parameters (a)

1. Select a velocity and acceleration to use for “Default Move Parameters”. These values will establish a standard move profile for each 7<sup>th</sup> axis move. These values can be customized for each move during programming (section 6.2.2 and 6.2.3).
2. Note that the tuning parameters will affect the maximum velocity and acceleration. See section 5.3.2.
3. For best results with the collision sensitivity, it is recommended that the most aggressive move needed is entered in the “Default Move Parameter”.

### 5.3.2 7<sup>th</sup> axis motor tuning (a)

Select a motor tuning of the below that is appropriate for your application. If unknown, utilize the “average” tuning.

- Gentle: for applications that require smooth and steady acceleration and decelerations. Examples may include moving testing and quality equipment through a scanning process.
- Average: a tuning that balances quick and smooth acceleration and deceleration. Applications may include machine tending, palletizing, and other general factory automation applications.
- Stiff: for applications that require quicker accelerations and decelerations. Examples may include welding and dispensing.

### 5.3.3 Running a test move (b)

This test move is used to establish a maximum current in the 7<sup>th</sup> axis motor drive.

1. Position the robot into a typical transfer position. It is recommended that the typical transfer position that will put the most moment load (i.e. side load) on the 7<sup>th</sup> axis be used here. If possible, have the robot carrying a typical payload.
2. Press and hold the “Move 7th Axis through Test Move” button. The 7<sup>th</sup> axis will move to the motor side switch. It will then travel at the default velocity and acceleration to the support-side limit switch.
3. Once the test move procedure is fully complete, hit “OK.” The indicator light should now be green. This indicates that an appropriate maximum current has been established for the 7<sup>th</sup> axis motor.

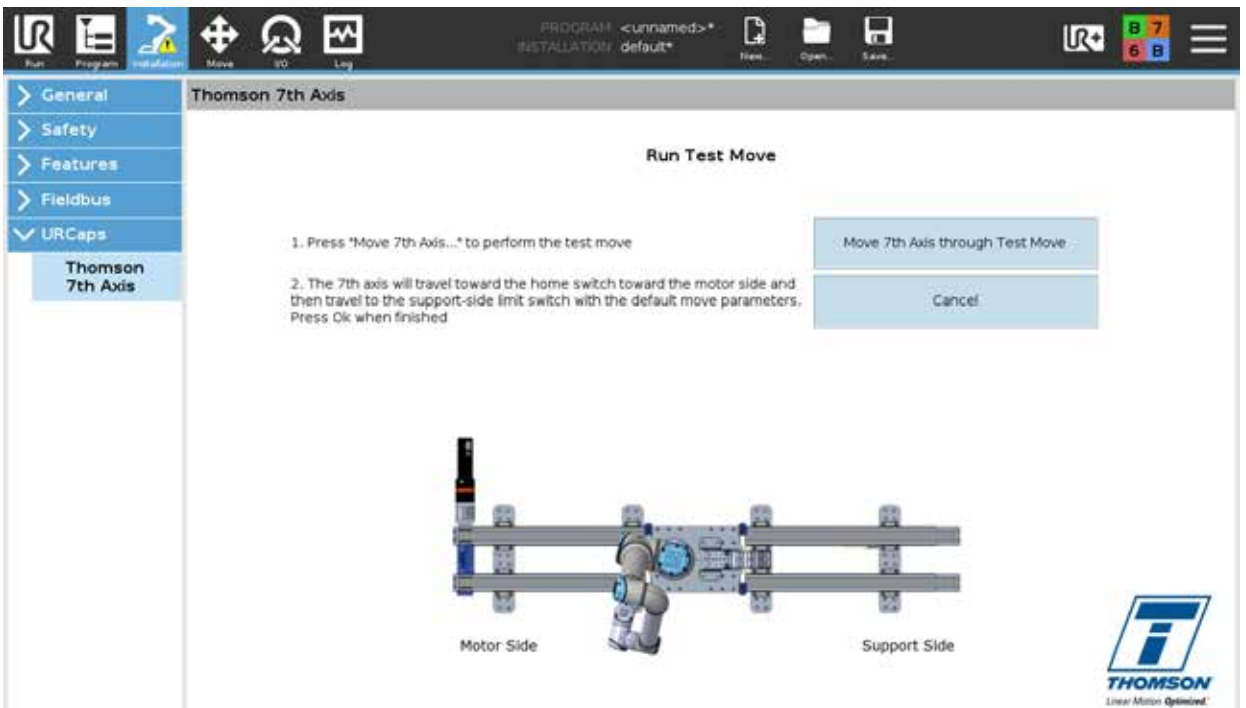
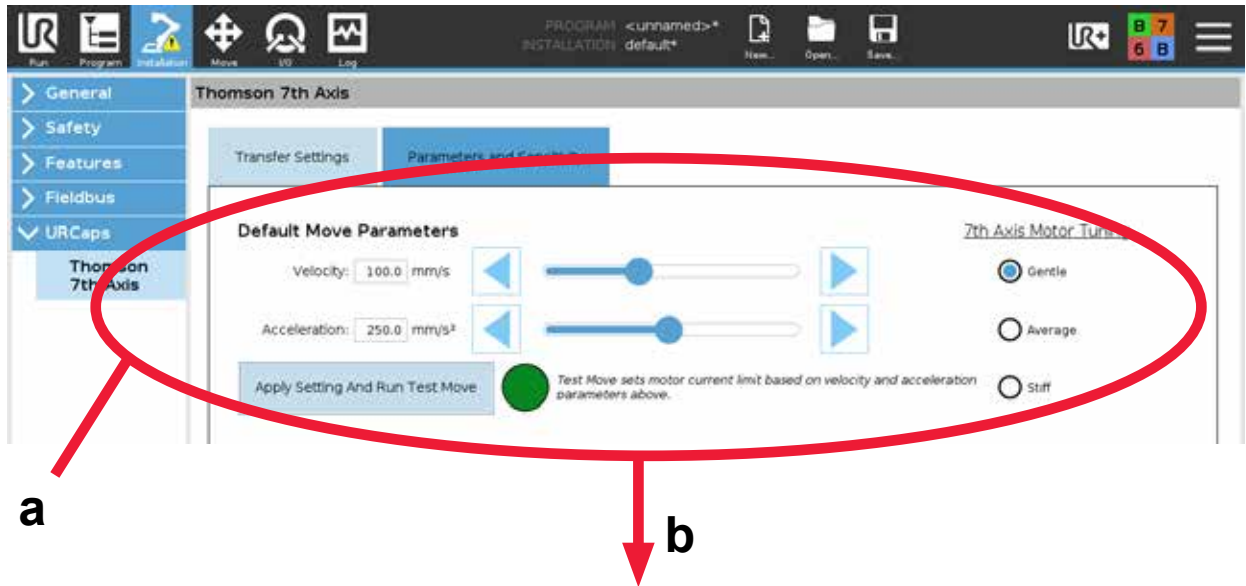

### 5.3.4 Collision sensitivity adjustment (a) and collision calibration move (b)

1. Adjust the bar to set the sensitivity of the collision detection system.
2. Next a collision calibration move needs to be run, which is a move utilized to validate the collision detection settings by creating an intentional fault.
3. Select a direction in which to move the 7<sup>th</sup> axis CTU. While holding this button, intentionally create a fault by contacting the base of the robot as seen in the pendant display. The base of the robot will ensure the fault is created on the 7<sup>th</sup> axis and not from a protective stop caused by hindering a joint of the articulated robot.
4. Based on the force required to create the fault:
  - If the sensitivity levels are acceptable, move on to programming.
  - If the force is too high or low, go back and adjust the sensitivity level on the slider bar and repeat the collision calibration move as necessary.

Note: If pressing the “Move 7th Axis.....” buttons on this screen results in a small move and an immediate sensitivity fault, the sensitivity value is set too tight. Adjust the slider bar to make the Movotrak CTU less sensitive and repeat the collision calibration move as necessary.



Collision detection settings are provided for your convenience. These are not official safety features. User is responsible for conducting their own risk analysis. When applicable, third-party safety devices should be used.

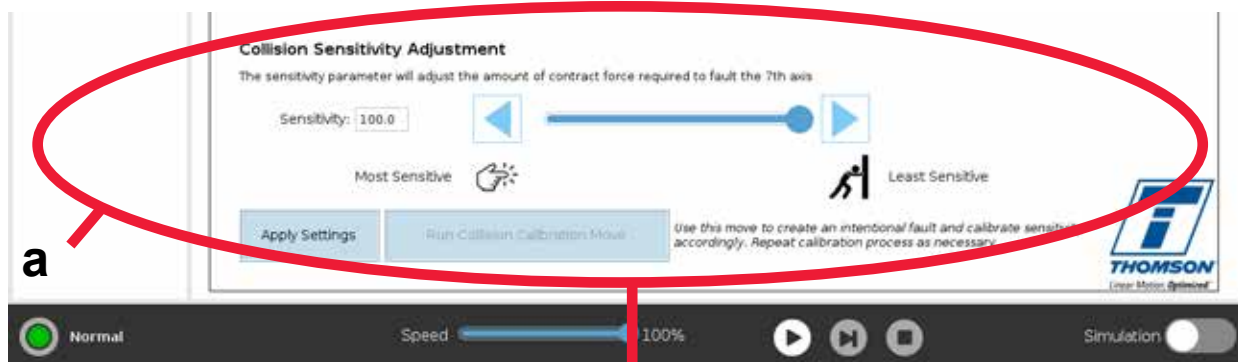

a

b

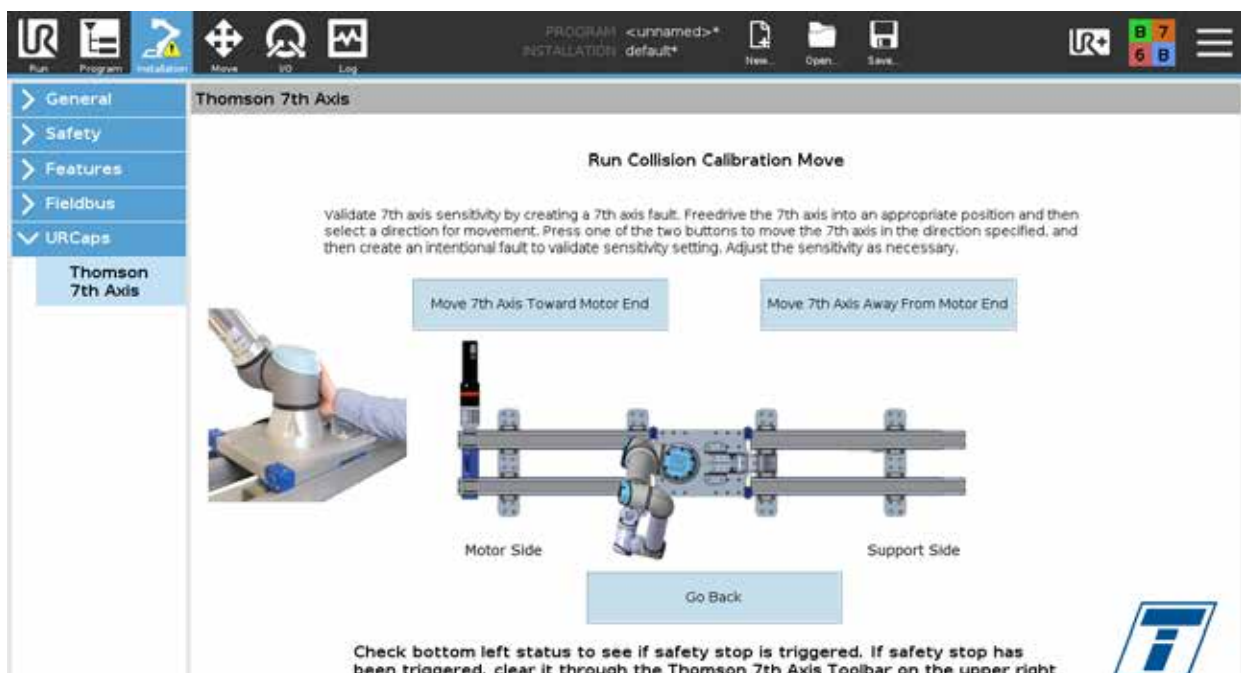

## 6. Programming of the Movotrak CTU system

### 6.1 General requirements

To program the unit, at least the following must be true:

1. The power must be turned on to the system.
2. No emergency stop or any of the safety collision systems can be activated.
3. Both the articulated robot and the 7<sup>th</sup> axis must have carried out a successful homing procedure.



Be careful when programming the system and make sure only qualified personnel necessary for the process are present.

### 6.2 Programming

#### 6.2.1 FreeDrive Mode

The 7<sup>th</sup> axis system can be moved by contacting the collision detection paddles when in FreeDrive mode. FreeDrive mode is activated by opening the 7<sup>th</sup> axis toolbar and select “7th Axis FreeDrive Mode”.

The paddles can be pushed or pulled, which will cause corresponding motion of the 7<sup>th</sup> axis system. The speed of the 7<sup>th</sup> axis is based on the force of the contact with the paddle. The 7<sup>th</sup> axis can then be positioned by hand – similar to the joints of the articulated robot.

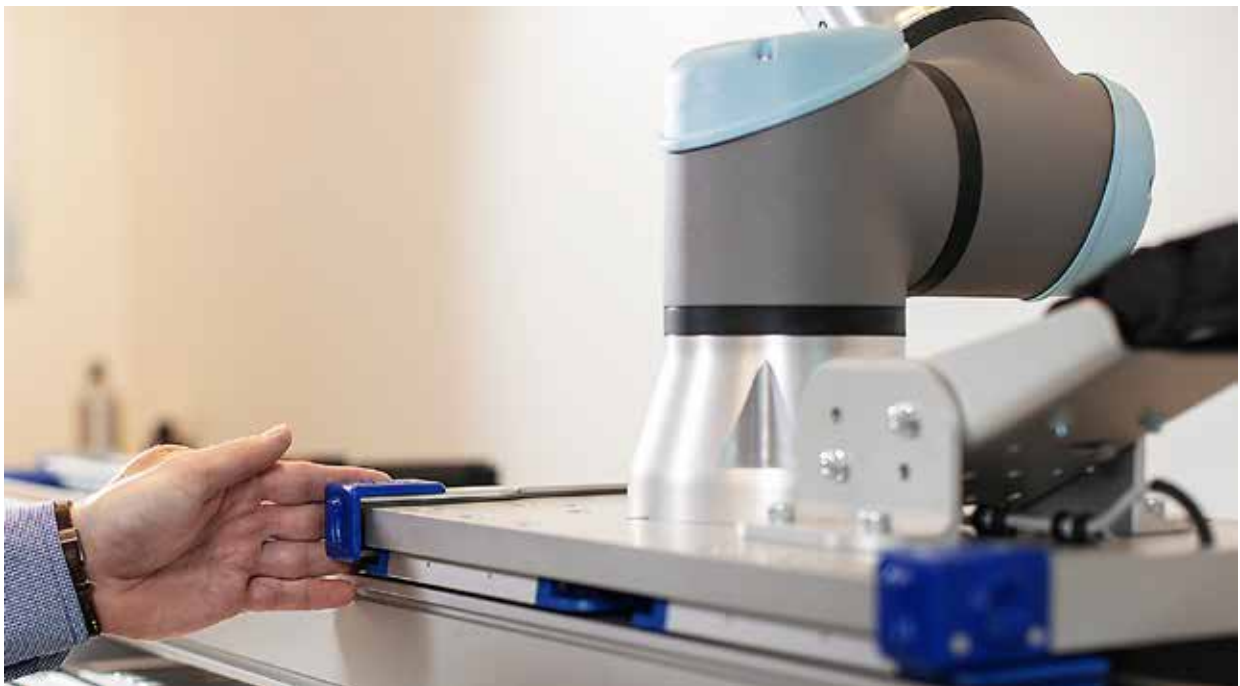

### 6.2.2 Programming an absolute move

An absolute move will move the 7th axis to a designated position. Example: an absolute move of 500 mm will move the 7th axis to 500 mm from the zero home position at the motor side limit switch irrespective of where the axis is at the moment. To set a linear waypoint, the 7th axis can be moved to the desired position in three ways:

1. Use the FreeDrive mode to position the 7th axis by hand.
2. Use the arrow keys on the “Absolute Move” tab to jog.
3. Type in the desired position to the “Desired Position” box.

The settings for velocity and acceleration will be set to the “Default Move Parameters”. These can be changed for this particular move by selecting the “Custom” option. Note that increasing the velocity and acceleration along with a lower collision sensitivity detection level may cause the collision detection system to activate even without a collision.

There is also a box for “Run Asynchronously”. Checking this box will allow the linear move to occur along with other waypoint moves performed by the articulated robot at the same time.

The indicators at the bottom of the tab indicate if the 7th axis is properly connected and homed or not.

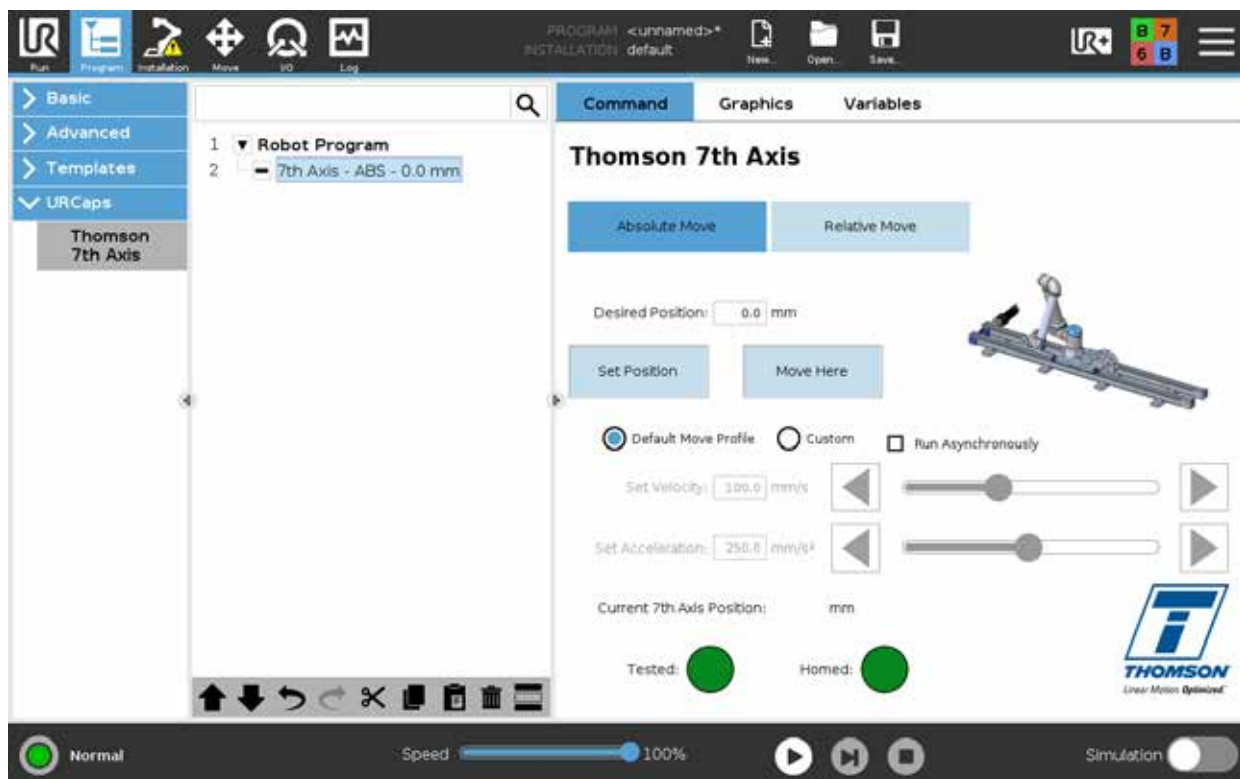

## 6.2.3 Programming a relative move

A relative move will move the 7<sup>th</sup> Axis the designated distance from its present location. In addition to the distance of the relative move, a direction of the move must also be selected. Example: a relative move of 500 mm towards the motor end will move the 7<sup>th</sup> axis 500 mm towards the motor end from its present position side. Note: If the incremental move would move the 7<sup>th</sup> axis outside of its stroke, motion will be aborted when reaching any of the limit switches.

To set a relative linear waypoint, type the distance into the “Set Relative Move” box. This move can be verified by using the “Move Here” button.

The settings for velocity and speed will be set to the “Default Move Parameters”. These can be changed for this particular move by selecting the “Custom” option. Note that increasing the velocity and acceleration along with a lower collision sensitivity detection level may cause the collision detection system to activate even without a collision.

There is also a box for “Run Asynchronously”. Checking this box will allow the linear move to occur along with other waypoint moves performed by the articulated robot at the same time.

The indicators at the bottom of the tab indicate if the 7<sup>th</sup> axis is properly connected and homed or not.

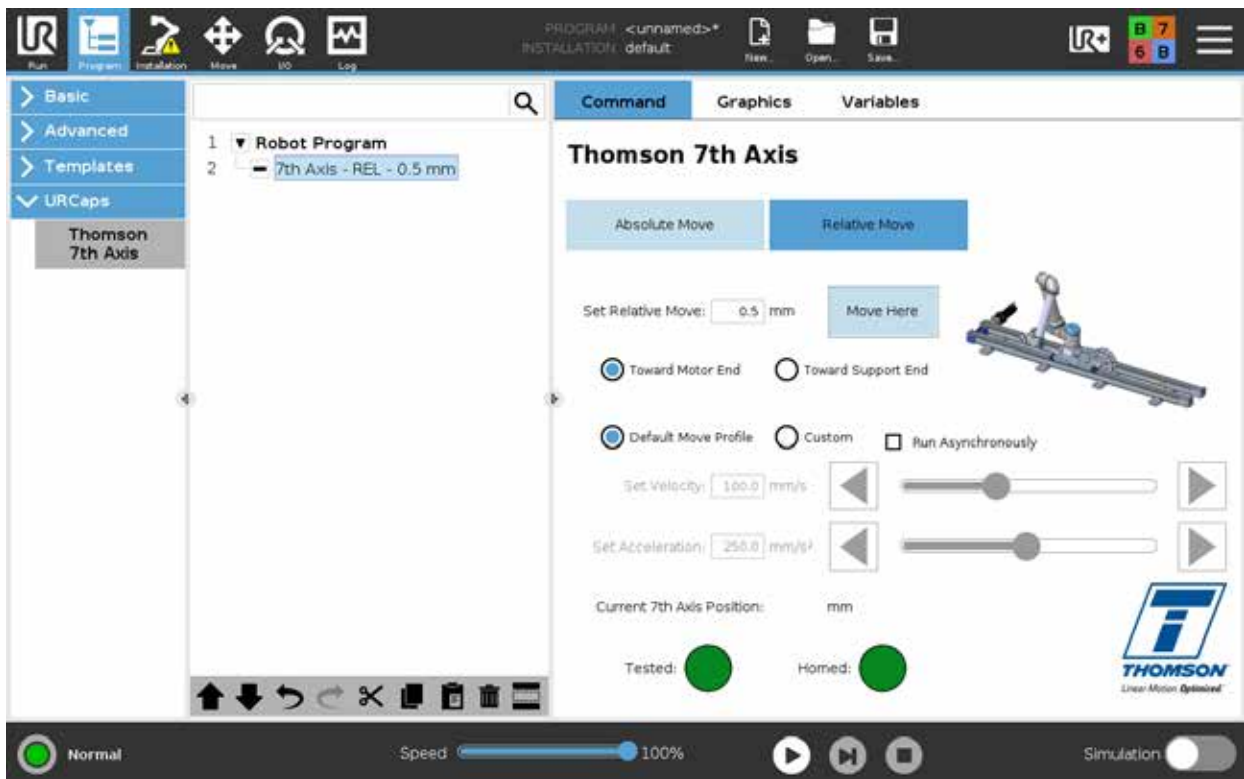

## 7. Collision detection system

### 7.1 Activation

Collision detection can be activated in two ways. Either by one of the collision detection paddles (section 3.3.1) coming in contact with an obstacle or by the collision sensitivity setting (section 5.3.4) being exceeded. In both cases, the articulated robot and the Movotrak CTU 7<sup>th</sup> axis will cause a safeguard stop. In order to resume operation after a collision detection stop has been triggered, it must first be reset (section 7.1.3).

#### 7.1.1 Activation by collision detection paddle touch

Contact with the collision detection paddle on either end of the carriage will cause a safeguard stop for the 7<sup>th</sup> axis and the articulated robot.



#### 7.1.2 Activation by the collision detection sensitivity feature

Exceeding the collision detection sensitivity setting will cause a safeguard stop for the the 7<sup>th</sup> axis and the articulated robot. It can be triggered by hitting an obstacle as well as by an overload condition.



### 9.3 Resetting a collision detection stop

Reset is done by pressing the “Clear” button on the teach pendant in the Thomson 7<sup>th</sup> axis toolbar.



Do not reset a collision detection stop and resume operation without knowing the cause of the stop and, if necessary, also have the issue that caused the stop corrected.

## 8. Troubleshooting

### 8.1 Troubleshooting

- Problem:** An emergency stop is issued as soon as system is turned on.  
**Issue:** The wiring and I/O setup is not correct.  
**Solution:**
1. Check that the I/O wiring to the Universal Robot controller (section 5.1.1) has been done correctly.
  2. Check that the instructions for safety I/O and general I/O (section 5.1.2) have been followed accordingly.
- Problem:** The CTU unit begins movement and stops suddenly before reaching the desired position.  
**Issue:** The collision detection sensitivity setting is being activated.  
**Solution:** The collision detection may activate, particularly if a custom move profile has been created with either a faster velocity or acceleration than the default move profile. Adjust the default move profile to those faster speeds and accelerations, and re-run the test move and calibration settings with that profile (section 5.3).
- Problem:** The CTU unit will not perform program moves. Homing indicator is red.  
**Issue:** Power has been removed previously, and the system axis has not been homed.  
**Solution:** The system needs to be homed. Return to the installation tab and run a homing move (section 5.2.4).
- Problem:** The program will not run.  
**Issue:** The default velocity and/or acceleration has been changed. A new "Test Move" needs to be done to set the proper current limit.  
**Solution:** Go to "Parameters and Sensitivity" tab in Thomson URCap installation and perform a "Test Move" (section 5.3.3).
- Problem:** Pendant indicates a problem communicating with the articulated robot.  
**Issue:** The robot to robot box cable is not plugged in correctly.  
**Solution:** Turn off the robot and plug in the cable (either at the UR box or at the robot, whichever is loose) and turn the robot system back on.

## 9. Technical data

### 9.1 Technical specifications

Technical Specification		CTU07
Input voltage	[Vac]	1 × 120/230 + PE (protective earth)
Input voltage tolerance	[%]	± 10
Input voltage frequency	[Hz]	50/60
Weight of control cabinet	[kg]	25
Stroke length	[mm]	up to 10000
Dynamic load in any direction, maximum CTUL(R)xxxxUR05(10, 16) CTUL(R)xxxxUR20(30)	[N]	500 850
Dynamic load torque in any direction, maximum CTUL(R)xxxxUR05(10, 16) CTUL(R)xxxxUR20(30)	[Nm]	425 900
Current draw @ rated max. load	[A]	8
Duty cycle, max	[%]	75
Operating temperature limits	[°C (°F)]	0 - 40 (32 - 105) *
Compliances		CE, RoHS, REACH (EU)

\* Operating at slightly higher ambient temperatures may be possible at lower speeds or/and derated duty cycle.

## 10. Certificates

### 10.1 Declaration of RoHS compliance



*Linear Motion. Optimized.™*

Thomson Industries

#### DECLARATION OF RoHS COMPLIANCE

EU RoHS Directive 2011/65/EU and Amendment 2015/863/EU

Substance/Substance Group	Threshold
Cadmium/Cadmium Compounds (Cd)	0.01% at homogeneous material level
Lead/Lead Compounds (Pb)	0.1% at homogeneous material level
Hexavalent chromium and Compounds (Cr6+)	0.1% at homogeneous material level
Mercury/Mercury Compounds (Hg)	0.1% at homogeneous material level
Polybrominated biphenyls (PBB)	0.1% at homogeneous material level
Polybrominated diphenyl ethers (PBDE)	0.1% at homogeneous material level
Bis(2-ethylhexyl) phthalate (DEHP)	0.1% at homogeneous material level
Butyl benzyl phthalate (BBP)	0.1% at homogeneous material level
Dibutyl phthalate (DBP)	0.1% at homogeneous material level
Diisobutyl phthalate (DIBP)	0.1% at homogeneous material level

To whom it may concern,

Item(s):

**CTU07**

We hereby send you information related to Article 4(1) of the EU RoHS (Restriction of Hazardous Substances) Directive (2011/65/EU). This communication applies to all Products sold or otherwise placed on the market by **Thomson Industries** prior to the signature date shown below.

**If no such Products contain any of the above-referenced substances over the given threshold (regardless of exemption status), this option must be selected:**

Checking this box certifies that none of the Products referenced above contain any of the listed substances at a concentration over the given threshold limit by weight at the homogeneous material level.

**OR, if any such Products contain any above-referenced substances over the given threshold level, the table below must be completed.** Each Product below is deemed to contain one or more of the above-referenced above the noted threshold, either without exemption or with the listed exemption(s). Products not listed do not contain restricted substances over threshold.

**RoHS List Status and applicable information**

Product(s)	RoHS Substance Group or Name	CAS Number (if available)	Exemption Number (if applicable)

**Limitations**

Thomson Industries believes that the information it provides above is accurate. The provided information is based upon data obtained from ongoing due diligence concerning goods and materials provided by third party suppliers. Thomson Industries provides such information "AS IS", without any express or implied warranty of any kind. Thomson Industries reserves the right to update and modify this communication, as it believes necessary or appropriate.

Please do not hesitate to ask for further information.

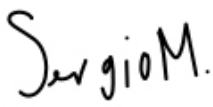
Print Name: Sergio Moreno Signed: 

Title: Material Compliance Coordinator Date: 4/02/2024

Email: sergio.moreno@regalrexnord.com Phone: \_\_\_\_\_

Address: \_\_\_\_\_

(cont'd) \_\_\_\_\_

## 10. Certificates

### 10.2 Kollmorgen declarations

<b>EU Declaration of Conformity</b>		<b>KOLLMORGEN</b> <small>A REGAL RENKORD BRAND</small>
We, the company		
Kollmorgen Corporation 201 W Rock Rd Radford VA, 24141-4099 USA		
hereby on our sole responsibility declare the conformity of the product series <b>Kollmorgen AKD2G</b> servo drives.		
<b>Models:</b>	AKD2G-Sxx-6V03S-xxxx-xxxx	AKD2G-Sxx-6V03D-xxxx-xxxx
	AKD2G-Sxx-6V06S-xxxx-xxxx	AKD2G-Sxx-6V06D-xxxx-xxxx
	AKD2G-Sxx-6V06H-xxxx-xxxx	AKD2G-Sxx-6V12S-xxxx-xxxx
	AKD2G-Sxx-7V03S-xxxx-xxxx	AKD2G-Sxx-7V03D-xxxx-xxxx
	AKD2G-Sxx-7V06S-xxxx-xxxx	AKD2G-Sxx-7V06D-xxxx-xxxx
	AKD2G-Sxx-7V06H-xxxx-xxxx	AKD2G-Sxx-7V12S-xxxx-xxxx
	AKD2G-Sxx-7V24S-xxxx-xxxx	
Where x is an alphanumeric character. See manual naming convention for options covered.		
Models followed by -A denotes a connector set shipped in the same box.		
with the following directives:		
The <b>Machinery Directive 2006/42/EC</b> using the following harmonized standard: EN 61800-5-2:2007 Adjustable speed electrical power drive systems – Part 5-2: Safety requirement – Functional		
The <b>Low Voltage Directive 2014/35/EU</b> , using the following harmonized standard: EN 61800-5-1: 2007 + A1:2017 + A11:2021 Adjustable Speed Electrical Power Drive Systems - Part 5-1		
The <b>EMC Directive 2014/30/EU</b> using the following harmonized standard: EN 61800-3: 2004 + A1: 2012 Adjustable Speed Electrical Power Drive Systems - Part 3		
CE Mark affixed to the drives first time 2019.		
<i>These products comply with the RoHS Directive 2011/65/EU including commission delegated Directive (EU) 2015/863 for installation in a machine. Safety depends upon installing and configuring the drive per the manufacturer's recommendations. The machine in which this product is to be installed must conform to the provisions of the EMC Directive 2014/30/EU.</i>		
<i>Additional information:</i>		
<i>Proper installation and operating instructions are available for use with this product.</i>		
<i>Technical File documentation (CE rationale and test certificates) is available (for EU authorities only).</i>		
<i>Production and change are controlled under ISO 9001:2015 certified processes and procedures. Risk Analysis according to ISO 12100. Other standards applied: EN 61800-2, EN 61800-3: 2018, UL 61800-5-1, and CSA 22.2 No. 274.</i>		
<i>See TUV certificate for Functional Safety.</i>		
Signed:		
David Digby Empson Compliance Engineer	13 June 2023	Kollmorgen Corporation 201 W Rock Road Radford VA, 24141-4099 540 639 2495

EU Declaration of Conformity

**KOLLMORGEN**  
A REGAL THOMSON BRAND





Deutsche  
Akademie für  
Prüfungsgesellschaften  
DZ-12074-01 DE

# Certificate

No. SEBS-A.095714/15 V1.1

TÜV NORD Systems GmbH & Co. KG hereby certifies

**Kollmorgen Corporation**  
501 West Main Street  
Radford VA 24141  
USA

that the safety functions within the

## AKD2G

(Advanced Kollmorgen Drive 2<sup>nd</sup> generation)

are capable for safety related application and meets the requirements listed in the following standards

- IEC 61508-1 / -2: 2010, SIL 2 / 3
- IEC 61800-5-2: 2016, SIL 2 / 3
- IEC 62061: 2005 + A1:2012 + A2:2015 + CSV/COR1:2015, SILcl. 2 / 3
- ISO 13849-1 / -2: 2015 / 2012, PL d / e, Cat. 3 / 4

Certificationprogram Leistungstechnik (SEB-ZE-SEECERT-VA-320-20, Rev. 5/14/19)

Base of certification is the report SEBS-A.095714/15TB and the certificate tracking list in the valid version.  
Safety functions with capable SIL are given in the certificate tracking list.  
This certificate entitles the holder to use the pictured conformity mark.

Valid until: 2025-04-02  
File reference: 8113573065

Augsburg, 2020-02-18

*B. Puff*  
Bianca Puff



Certification Body SEECERT  
TÜV NORD Systems GmbH & Co. KG  
Große Bahnstraße 31, 22625 Hamburg, Germany

## 10. Certificates

### 10.3 Kollmorgen declarations

<b>EU Declaration of Conformity</b>	<b>KOLLMORGEN</b>
We, the company	
Kollmorgen Corporation 201 W Rock Rd Radford VA, 24141-4099 USA	
hereby on our sole responsibility declare the conformity of the product series	
<b>Product:</b>	<b>3Φ PM SERVO MOTOR</b>
<b>Series:</b>	<b>Kollmorgen AKM2G</b>
<b>Models:</b>	<b>Types 2, 3, 4, 5, 6, and 7 - followed by additional letters and/or numbers.</b>
with the following directives:	
The Low Voltage Directive 2014/35/EU, using the following harmonized standards:	
EN 60034-1:2010/AC:2010	Rotating electrical machines Part 1
EN 60034-5:2001/A1:2007	Rotation electrical machines Part 5
The EMC Directive 2014/30/EU using the following harmonized standard:	
EN 61800-3: 2004/A1:2012	Adjustable Speed Electrical Power Part 3
CE Mark affixed to the motors first time 2017.	
<i>These products comply with the RoHS Directive 2011/65/EU including commission delegated Directive (EU) 2015/863 for installation in a machine. Safety depends upon installing and configuring the motor per the manufacturer's recommendations. The machine in which this product is to be installed must conform to the provisions of the EMC Directive 2014/30/EU. The installer is responsible for ensuring that the end product complies with the EMI requirements and all of the relevant laws in the country where the equipment is installed.</i>	
<i>Additional information: Proper installation and operating instructions are available for use with this product. Technical File documentation (CE rationale and test certificates) is available (for EU authorities only). Production and change is controlled under ISO 9001:2015 certified processes and procedures. Other standards applied: UL 1004-1, UL 1004-6, and CSA 22.2 No. 100.</i>	
Signed:	
	Kollmorgen Corporation
David Digby Empson	201 W Rock Road
Compliance Engineer	Radford VA, 24141-4099
20 June 2019	540 639 2495



**USA, CANADA and MEXICO**

Thomson  
203A West Rock Road  
Radford, VA 24141, USA  
Phone: 1-540-633-3549  
Fax: 1-540-633-0294  
E-mail: [thomson@regalrexnord.com](mailto:thomson@regalrexnord.com)  
Literature: [literature.thomsonlinear.com](http://literature.thomsonlinear.com)

**EUROPE****United Kingdom**

Thomson  
Office 9, The Barns  
Caddsdow Business Park  
Bideford, Devon, EX39 3BT  
Phone: +44 1271 334 500  
E-mail: [thomson.europe@regalrexnord.com](mailto:thomson.europe@regalrexnord.com)

**Germany**

Thomson  
Nürtinger Straße 70  
72649 Wolfschlügen  
Phone: +49 7022 504 403  
Fax: +49 7022 504 405  
E-mail: [thomson.europe@regalrexnord.com](mailto:thomson.europe@regalrexnord.com)

**France**

Thomson  
Phone: +33 243 50 03 30  
E-mail: [thomson.europe@regalrexnord.com](mailto:thomson.europe@regalrexnord.com)

**Italy**

Thomson  
Via per Cinisello 95/97  
20834 Nova Milanese (MB)  
Phone: +39 0362 366406  
Fax: +39 0362 276790  
E-mail: [thomson.italy@regalrexnord.com](mailto:thomson.italy@regalrexnord.com)

**Sweden**

Thomson  
Bredbandsvägen 12  
29162 Kristianstad  
Phone: +46 44 590 2400  
Fax: +46 44 590 2585  
E-mail: [thomson.europe@regalrexnord.com](mailto:thomson.europe@regalrexnord.com)

**ASIA****Asia Pacific**

Thomson  
E-mail: [thomson.apac@regalrexnord.com](mailto:thomson.apac@regalrexnord.com)

**China**

Thomson  
Rm 805, Scitech Tower  
22 Jianguomen Wai Street  
Beijing 100004  
Phone: +86 400 606 1805  
Fax: +86 10 6515 0263  
E-mail: [thomson.china@regalrexnord.com](mailto:thomson.china@regalrexnord.com)

**India**

Kollmorgen – Div. of Altra Industrial Motion  
India Private Limited  
Unit no. 304, Pride Gateway,  
Opp. D-Mart,  
Baner Road, Pune, 411045  
Maharashtra  
Phone: +91 20 67349500  
E-mail: [thomson.india@regalrexnord.com](mailto:thomson.india@regalrexnord.com)

**South Korea**

Thomson  
3033 ASEM Tower (Samsung-dong)  
517 Yeongdong-daero  
Gangnam-gu, Seoul, South Korea (06164)  
Phone: + 82 2 6001 3223 & 3244  
E-mail: [thomson.korea@regalrexnord.com](mailto:thomson.korea@regalrexnord.com)

**SOUTH AMERICA****Brazil**

Thomson  
Av. João Paulo Ablas, 2970  
Jardim da Glória - Cotia SP - CEP: 06711-250  
Phone: +55 11 4615 6300  
E-mail: [thomson.brasil@regalrexnord.com](mailto:thomson.brasil@regalrexnord.com)

[www.thomsonlinear.com](http://www.thomsonlinear.com)

Movotrak\_CTU\_Installation\_Operation\_ABB1 | 20250922TJ  
Specifications are subject to change without notice. It is the responsibility of the product user to determine the suitability of this product for a specific application. All trademarks property of their respective owners. ©2025 Thomson Industries, Inc.

The logo features a stylized 'T' inside a square frame, followed by the word 'THOMSON' in a bold, italicized, sans-serif font.

A REGAL REXNORD BRAND