

Roundway Bearing Seals

Seals are recommended for applications in which bearings must be protected against dust, chips, abrasive materials or corrosive environments, or where it is desirable to retain lubricant.

The Thomson Roundway bearing seal (Fig A) is a very effective sealing unit. It has a two-piece plastic enclosure which is easily installed around the bearing race and roller assembly. The seal is completely self-aligning; this assures sealing of the bearing race and roller assembly by maintaining contact with the Roundway at both sides and both ends of the sealing unit. Synthetic Roundway wipers on each end of the seal remove foreign particles from the Roundway and prevent their entry into the roller-way contact.

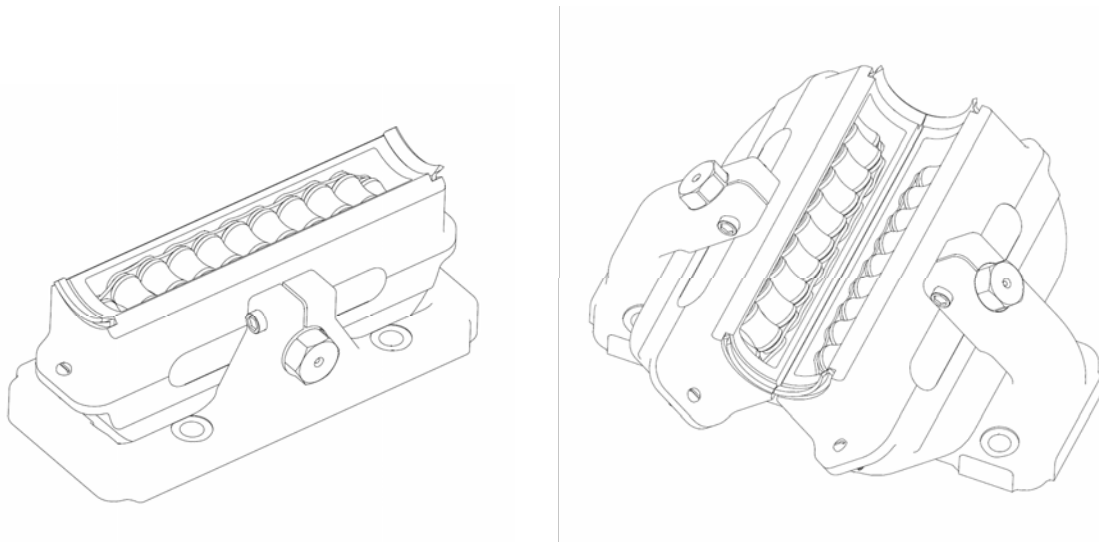
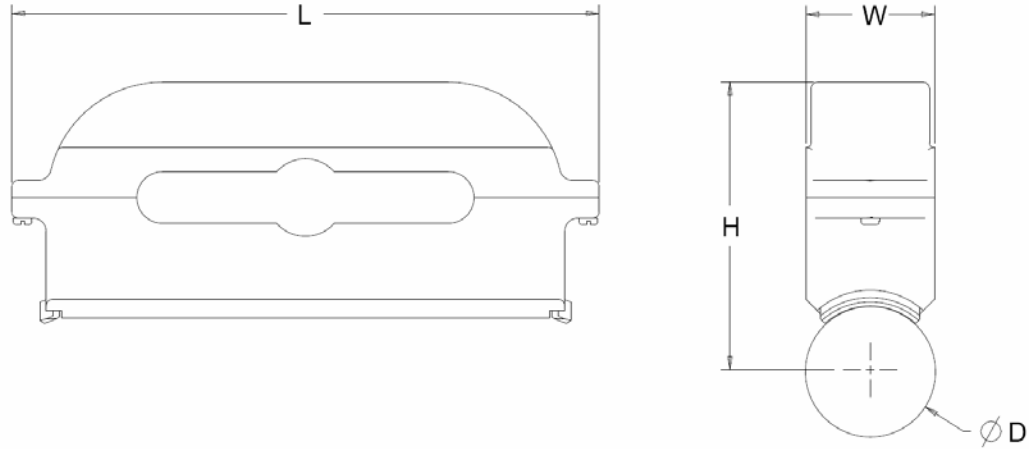

Figure A: Roundway 'S' bearing (left) and Roundway 'V' bearing (right)

The Roundway Bearing seals fit into the standard mounting blocks 'S' and 'V'. The dimensions listed in Table A permit necessary allowances to be made for seals used in tight clearance applications.

Roundway Bearing Seals Dimensions



Roundway Linear Roller Bearing Seal				
Part Number	Nominal Dia. D	Overall Length L	Overall Width W	Height from Shaft Centerline H
<i>1/2" seal size not available</i>				
RS-16	1.000	5.0	1.00	2.25
RS-24	1.500	6.5	1.38	3.25
RS-32	2.000	8.5	1.88	4.25
RS-48	3.000	13.0	2.63	6.25
RS-64	4.000	17.0	3.38	8.25

Table A: Roundway Bearing Seal Dimensions

Roundway Bearing Seal Assembly Instructions

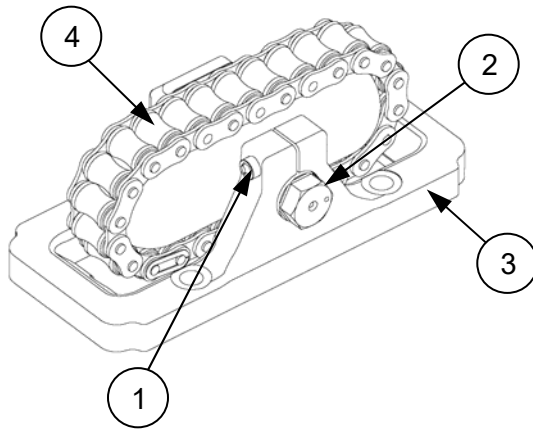

Figure B: Roundway Bearing Assembly

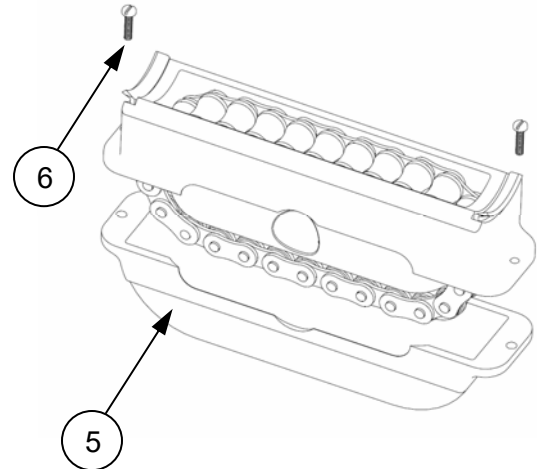

Figure C: Seal Assembly

1. Unscrew the locking screw (1).
2. Remove trunnion pin (2) from mounting block (3).
3. Place Roundway bearing (4) between seal cover halves (5).
4. Fasten seal cover together with pan head screw and nut (6).
5. Slide trunnion pin (2) back through mount (3) and Roundway bearing (4). Be sure that the pin is pressed fully into the mount, so that the pin shoulder butts up against the mount.
6. Adjust Roundway bearing height as needed by turning trunnion pin. The dot on the end of the pin indicates the high point of eccentricity.
7. Torque locking screw (1) per Table B.

Assembly Size	16	24	32	48	64
Screw Thread	10-32	10-32	1/4-20	3/8-16	7/16-14
Seating Torque (in-lbs)	60	60	100	350	580

Table B: Locking Screw Seating Torques