

### Roundway Bearing Installation

The height of the Roundway bearing can be adjusted to compensate for variations in the surface of the carriage underside by rotating the eccentric trunnion pin (Fig. A).

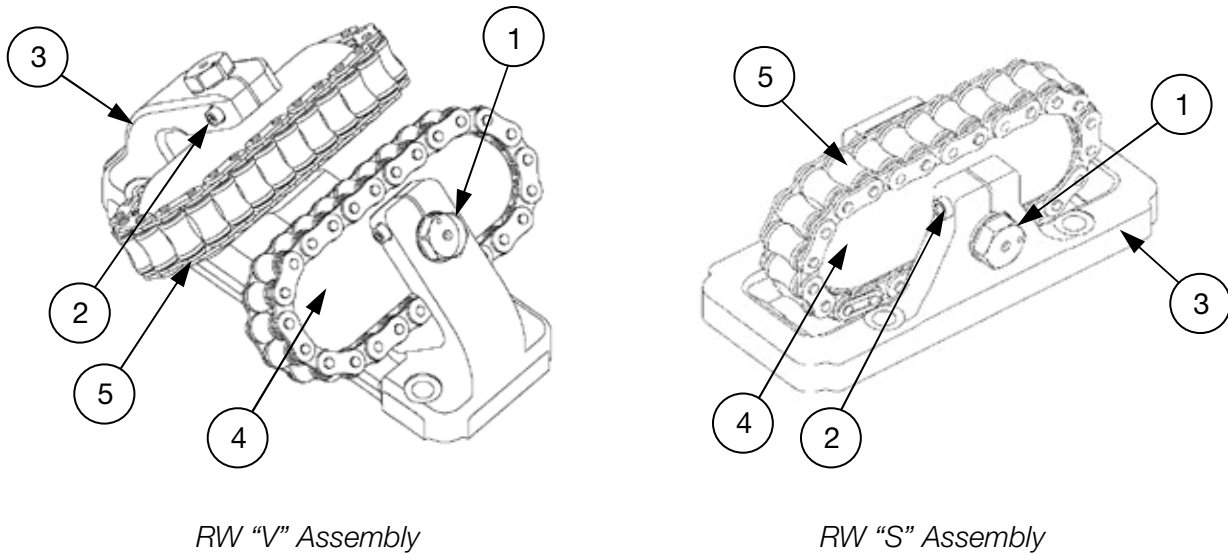

Item	1	2	3	4	5
<b>Component</b>	Trunnion Pin	Locking Screw	Mount	Race	Roller Chain
<b>Qty, Type "S"</b>	1	1	1	1	1
<b>Qty, Type "V"</b>	2	2	1	2	2

Figure A: Roundway Components

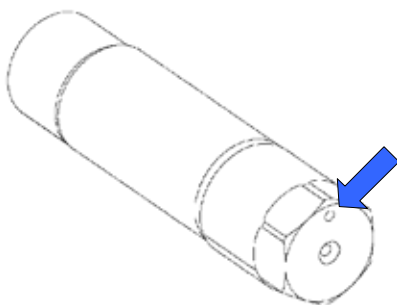

Figure B: Trunnion Pin Mark

The dot on the end of the trunnion pin (Fig. B) indicates the high point of eccentricity. Adjustability ranges are shown in Table 1. Be sure that the pin is pressed fully into the mount, so that the pin shoulder butts up against the mount. After adjustment, the height is locked in simply by tightening the lock screw. The lock screw can be inserted from the opposite end of the hole to help access. Lock screw torques are specified in Table 2.



A REGAL REXNORD BRAND

<b>Assembly Size</b>	16	24	32	48	64
<b>“S” Type Adjustability (in.)</b>	+/- .020	+/- .020	+/- .020	+/- .040	+/- .040
<b>“V” Type Adjustability (in.)</b>	+/- .015	+/- .015	+/- .015	+/- .030	+/- .030

Table 1: Roundway Adjustability Ranges

<b>Assembly Size</b>	16	24	32	48	64
<b>Screw Thread</b>	10-32	10-32	1/4-20	3/8-16	7/16-14
<b>Seating Torque (in-lbs)</b>	60	60	100	350	580

Table 2: Locking Screw Seating Torques

### Roundway Bearing Preloading

The eccentric trunnion pins provide a simple means for preloading Roundway bearings in those applications where no play can be tolerated. However, preloading should be applied only to give the required rigidity. Excessive preloading will cause unnecessary friction and wear.

A suggested procedure is to align the bearings to the point that all rollers circulate continuously as they are moved. This is a line-to-line fit. Next, gradually increase the preload until the desired rigidity is achieved. This is determined by applying the external load and measuring the deflection with an indicator. While increasing the preload, measure or feel the rolling friction. A sudden increase in friction indicates excessive preloading.

While the Roundway bearing is self-aligning in all directions, care should be taken when installing the bearings and shafting. Excessive variations in running parallelism can lead to additional preloading of the bearings.

### Lubrication

The Roundway bearings should be lubricated to increase the bearing life and minimize corrosion of the bearing surfaces. Grease lubrication is usually recommended for Roundway bearings, as grease will provide adequate lubrication and sealing is simplified. The choice of the grease to use for a specific application should be based on conditions of temperature, speed and nature of the environment.

It is recommended that you lubricate the Roundway bearing prior to installation and periodically during operation to assure that the bearing does not run dry.