

Precision Linear Actuators

New! T Series with RediMount™ motor mounting adapter kit available as standard



Thomson – Engineering Linear Motion for a Rapidly Evolving World

From precision linear motion solutions to fully integrated actuation systems, Thomson delivers intelligent, clean and efficient motion to help customers compete and scale. Whether your application demands speed, load capacity, controllability, compact design or long-term reliability, we help you design the right solution, not just the right part.

Thomson stands apart through:

- One of the industry's most comprehensive portfolios of linear motion and actuation solutions.
- Engineered-to-fit solutions, from configurable standards to application-specific designs developed in close collaboration with your team.
- Eighty years of proven application expertise across medical, industrial automation, aerospace and defense, mobile off-highway, material handling, transportation, robotics and more.

Engage with our engineering teams early to reduce design cycles, improve system integration and maximize long-term value. Product and application information, 3D models, sizing and selection tools, and global contact information are available at thomsonlinear.com



As a leading brand of Regal Rexnord, Thomson uniquely connects linear and actuation solutions with motors, controls, power transmission and drive technologies for enabling smarter integration, expanded design flexibility and enterprise-level support worldwide. Together with Regal Rexnord's 30,000 associates around the world, we help create a better tomorrow with sustainable solutions that power, transmit and control motion.

Local Support Around the Globe



Table of Contents

Table of Contents	3	Glossary	79
Introduction	4	A – Ce.....	79
Applications	6	Co – Du.....	80
The Benefits of Electrification	7	Dy – Lif.....	81
Performance Overview	8	Lin – Po.....	82
Precision Linear Actuator Range - T Series.....	8 - 9	Pr – Sta.....	83
Precision Linear Actuator Range - ECT Series.....	10 - 11	Str – Th.....	84
T Series	12	Application Data Form Worksheet	85
Introduction.....	12	Drawing/Notes.....	86
Overview.....	13		
T60.....	14 – 15		
T90.....	16 – 17		
T130.....	18 – 19		
ECT Series	20		
Introduction.....	20		
Overview.....	21		
ECT90 - Parallel IEC90 AC motor.....	22 - 23		
ECT90 - Parallel B43 AC Servo Motor.....	24 - 25		
ECT90 - Parallel B53 AC Servo Motor.....	26 - 27		
ECT90 - Direct Drive, Inline B43 AC Servo Motor.....	28 - 29		
ECT90 - Direct Drive, Inline B53 AC Servo Motor.....	30 - 31		
ECT90 - Planetary Gear, Inline B43 AC Servo Motor.....	32 - 33		
ECT90 - Planetary Gear, Inline B53 AC Servo Motor.....	34 - 35		
ECT130 - Parallel IEC100 AC Motor.....	36 - 37		
ECT130 - Parallel B53 AC Servo Motor.....	38 - 39		
ECT130 - Parallel B63 AC Servo Motor.....	40 - 41		
ECT130 - Direct Drive, Inline B53 AC Servo Motor.....	42 - 43		
ECT130 - Direct Drive, Inline B63 AC Servo Motor.....	44 - 45		
ECT130 - Planetary Gear, Inline B53 AC Servo Motor.....	46 - 47		
ECT130 - Planetary Gear, Inline B63 AC Servo Motor.....	48 - 49		
Options and Accessories	50		
Mounting.....	50 - 53		
Adapters.....	54 - 57		
Flanges and Gears.....	58 - 67		
Motors.....	68		
Sensors.....	69		
Environmental Protection.....	70		
Shafts and Flanges for Non-RediMount Units.....	71		
Ordering Keys	74		
How to Order.....	74		
T60, T90 and T130.....	74		
ECT90.....	75 - 76		
ECT130.....	77 - 78		



Introduction

Thomson is one of the leading suppliers of motion control products in the world, offering a complete product portfolio. Actuators, servo motors, lead screws, servo drives and controls are just some of the products manufactured by Thomson. The precision linear actuator range is a result of more than 40 years of actuator development and represents the state of the art in linear actuator design.

The precision linear actuators in this catalog represent the experience gained during decades of actuator development. The result is design concepts that will work in the most demanding applications imaginable and unique product features unavailable anywhere else.

Worldwide representation

Thomson has plants, support centers and sales offices all around the globe. In addition, we have a large network of distributors and system houses that all are ready to support you throughout the entire lifecycle of the product.

Thomson - a complete supplier

Thomson develops, produces and sells motion control products of all types. If you need a servo drive, programmable control or

linear guide to match your precision linear actuator, you can rest assured that Thomson has the ideal choice for your application. Please visit www.thomsonlinear.com for more information.

Online resources

You can find online resources, such as CAD models, literature and product data, for the precision linear actuator range at www.thomsonlinear.com/pla.

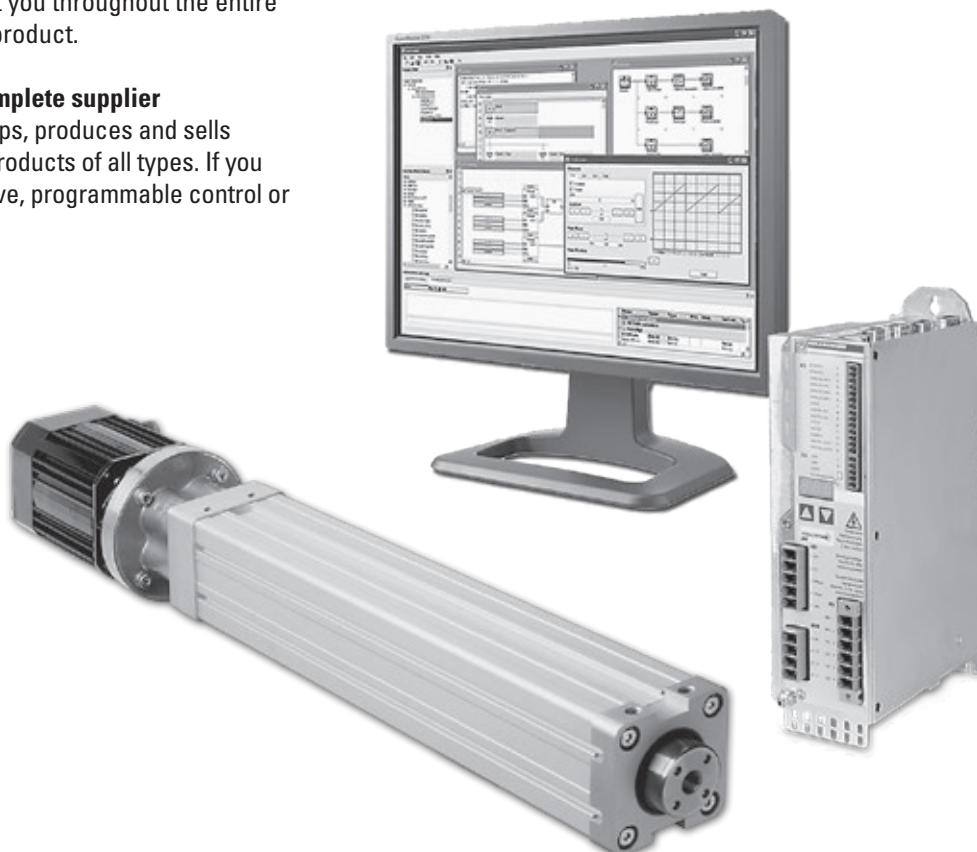

Introduction

Precision linear actuators are used in handling, machining and manufacturing applications. Another suitable area is in the replacement of hydraulic or pneumatic cylinders where they bring many benefits compared to these traditional technologies. A broad range of options and accessories, and our vast experience in building customized units makes it easy to find the perfect actuator for almost any application.

The hallmark for Thomson precision linear actuators is the ability to work hard, fast and accurately, day in and day out, under the toughest conditions. All precision linear actuators are designed to require a minimum of maintenance. There are no parts that need to be replaced due to wear, and regular lubrication is needed only in applications where the actuator works hard and frequently.

Hydraulics and pneumatics replacement

Precision linear actuators are direct descendants of hydraulic and pneumatic cylinders. Possessing many of the same unique design characteristics that made hydraulic and pneumatic cylinders popular, actuators benefit from cleaner, simpler and more energy-efficient power transmission. They are also much easier to integrate with modern programmable controls, have greater accuracy and are less noisy.

Harsh environments

Chemical plants, paper mills, welding operations and outdoor applications are all suitable for precision linear actuators. IP65 protection as standard or an option, a robust design and the use of high-quality components make them suitable for virtually every location.

Customized units

Customization is one of our strengths, and we have built hundreds of one-of-a-kind units. If you need a special stroke, a unique mounting bracket, or some other adaptation of the standard product, our engineers will help you find the perfect solution for your application. Please contact customer service for more information.

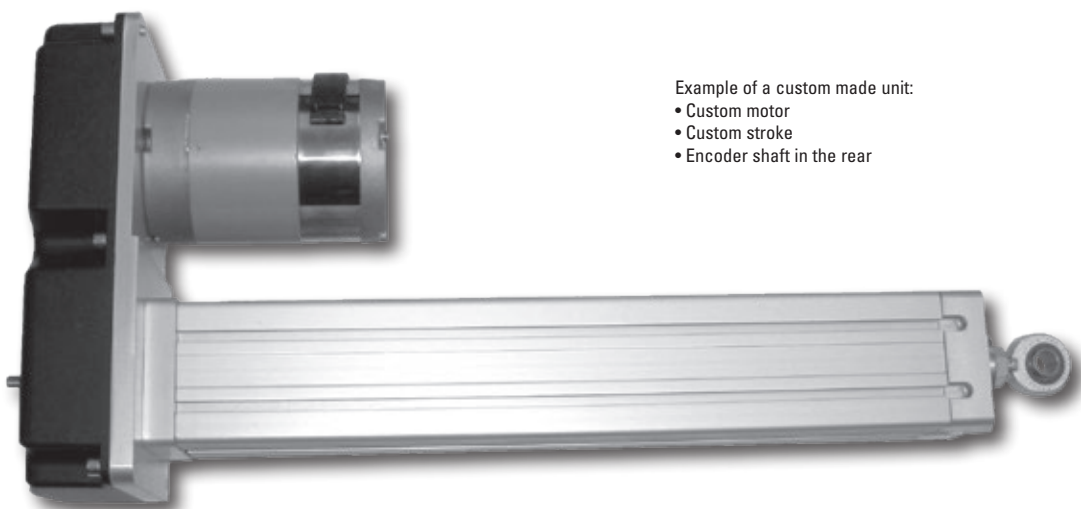

Example of a custom made unit:

- Custom motor
- Custom stroke
- Encoder shaft in the rear



Applications

Precision linear actuators can fit a wide variety of applications within many motion industries. In combination with high-performance drives and controls from Thomson, designing these actuators into linear motion equipment is made simple. Some common applications are described below.

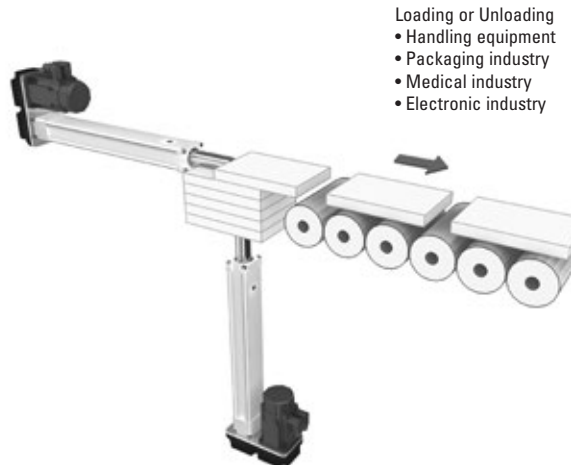
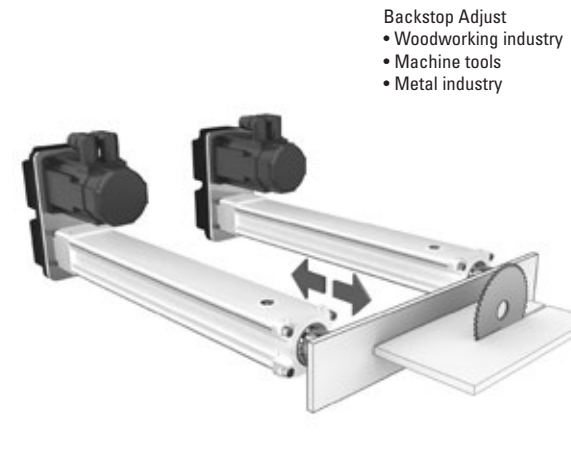
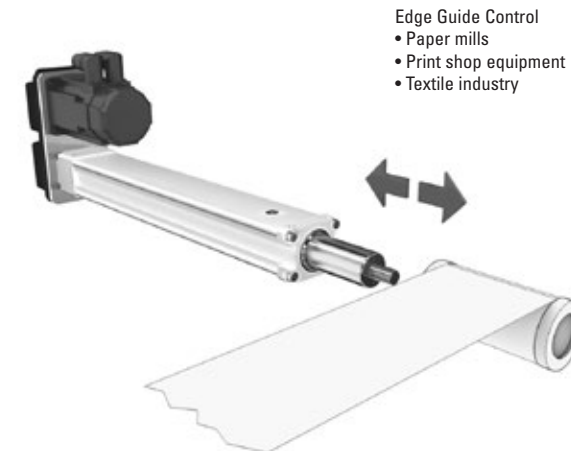
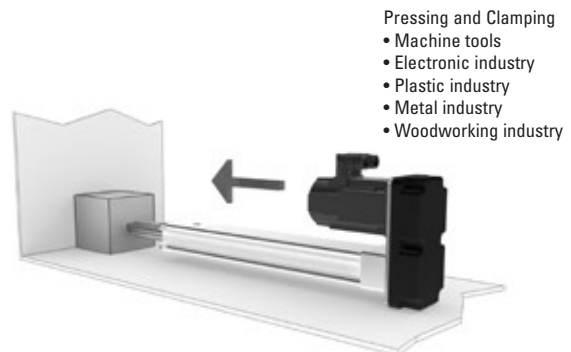

The Benefits of Electrification

Precision linear actuators are often a better choice than hydraulic or pneumatic alternatives due to simpler installation, easier control, lower energy costs, higher accuracy, less maintenance and noise, and a cleaner, healthier environment.

Electric Actuators vs. Hydraulic and Pneumatic Cylinders			
	Electric Linear Actuators	Hydraulic Cylinders	Pneumatic Cylinders
Installation	All electric operation requires simple wiring.	Requires expensive plumbing, filtering, pumps, etc.	Requires expensive plumbing, filtering, pumps, etc.
Accuracy	Very repeatable (to $\pm 0,013$ mm) and rigid, multi-stop capabilities.	Requires expensive position sensing and precise electro-hydraulic valving to implement. Has tendency to creep.	Difficult to achieve. Requires expensive position sensing and precise valving to implement. Has tendency to creep.
Control	Directly compatible with standard programmable controls, allowing easy, automatic operation of complex motion sequences.	Requires electronic/fluid interfaces and exotic valve designs. Hysteresis, dead zone, supply pressure and temperature changes complicate control.	Inherently non-linear, compressible power source severely complicates servo control.
Speed	Smooth, variable speed from 0 to 2 m/s with controlled acceleration.	Difficult to control accurately. Varies with temperature and wear. Stick slip can be a problem.	More susceptible to stick slip and varying load. Well-suited for light, high-speed applications.
Reliability	Repeatable, reproducible performance during the entire product life. Very little maintenance required.	Very contamination sensitive. Require regular maintenance. Seals are prone to leak. Reliable with diligent maintenance.	Very contamination sensitive. Air sources require proper filtration. Good reliability, but usually many system components are involved.
Power	Up to 40 000 N	Virtually unlimited force. Most powerful.	Up to 25 000 N. Typically used below 6 000 N.
Life expectancy	Up to millions of cycles at rated load. Easy to predict.	Dependent on design and seal wear, usually good.	Dependent on design and seal wear, usually good.
Environment	Standard models rated for -30 to +70°C. Inherently clean and energy efficient.	Temperature extremes can be a major problem. Seals are prone to leak. Waste disposal is increasingly problematic.	Temperature extremes can be a major problem. Seals prone to leak. Airborne oil can be a problem.
Load holding	Acme screw units are self-locking if power fails. Fail-safe brakes available for ball screw models.	Complex backup safety devices must be used.	Complex backup safety devices must be used.
Cost	Moderate initial cost, very low operating cost.	Components often cost less, but installation and maintenance are increased. Hydraulic power unit cost is high if not pre-existing.	Components often cost less, but installation and maintenance are increased.



Performance Overview

Precision Linear Actuators - T Series

T60



Load			
Maximum load, Fx	[N]	10 000	
Maximum load, Fy	[N]	100	
Maximum load, Fz	[N]	100	
Maximum load torque, Mx	[Nm]	-	
Maximum load torque, My	[Nm]	50	
Maximum load torque, Mz	[Nm]	50	
Stroke			
Maximum standard stroke	[mm]	1500	
Speed			
Maximum speed	[m/s]	2,5	
Accuracy			
Repeatability	[± mm]	0,05	
Backlash	[mm]	0,11	
General data			
Profile size (width × height)	[mm]	75 × 60	
Operating temperature limits	[°C]	-20 – +70	
Maximum duty cycle	[%]	100	
Screw diameter	[mm]	25	
Screw type		ball screw	
Protection class - standard / optional		IP65	
Features			
RediMount motor mounting system		•	
Single point lubrication		•	
Mounting options			
Magnetic position sensors		•	
Mounting feet kit		on request	
Trunnion mounting kit		•	
Clevis mounting kit		•	
Tube end - inside thread / outside thread / spherical joint		•/•/•	

¹ Depending on the screw diameter used in the actuator.

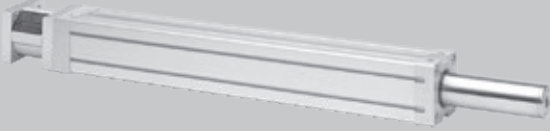
	T90	T130
		
	20 000	60 000
	500	800
	500	800
	-	-
	150	300
	150	300
	1500	2000
	2,0	2,0
	0,05	0,05
	0,11 (0,18) ¹	0,21
	90 × 92	130 × 130
	-20 – +70	-20 – +70
	100	100
	25, 32	40, 50
	ball screw	ball screw
	IP65	IP65
	•	•
	•	•
	•	•
	•	•
	•	•
	•	•
	•/•/•	•/•/•



Performance Overview

Packaged Precision Linear Actuators - ECT Series

ECT90

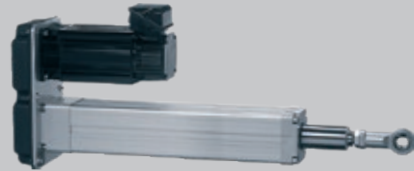

Load			
Maximum load, Fx	[N]	20 000	
Maximum load, Fy	[N]	500	
Maximum load, Fz	[N]	500	
Maximum load torque, Mx	[Nm]	-	
Maximum load torque, My	[Nm]	150	
Maximum load torque, Mz	[Nm]	150	
Stroke			
Maximum standard stroke	[mm]	1500	
Speed			
Maximum speed	[m/s]	1,6	
Accuracy			
Repeatability	[± mm]	0,05	
Backlash	[mm]	0,11 (0,18) ¹	
General data			
Profile size (width × height)	[mm]	90 × 92	
Operating temperature limits	[°C]	-20 – +70	
Maximum duty cycle	[%]	100	
Screw diameter	[mm]	25, 32	
Screw type		ball screw	
Protection class - standard / optional		IP65	
Features			
Brushless AC servo motor / Three phase AC motor		•/•	
Single point lubrication		•	
Mounting options			
Magnetic position sensors		•	
Mounting feet kit		•	
Trunnion mounting kit		•	
Clevis mounting kit		•	
Tube end - inside thread / outside thread / spherical joint		•/•/•	

¹ Depending on the screw diameter used in the actuator.

ECT130

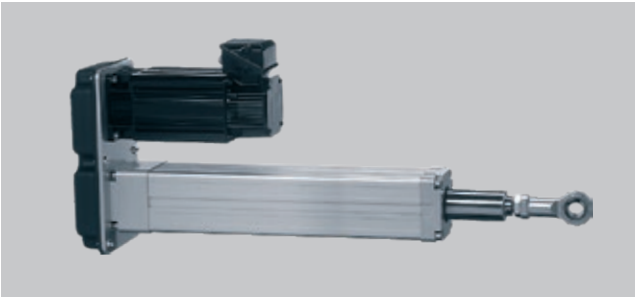

	38 000
	800
	800
	-
	300
	300
	2000
	2,0
	0,05
	0,21
	130 × 130
	-20 – +70
	100
	40
	ball screw
	IP65
	•/•
	•
	•
	•
	•
	•
	•
	•/•/•



T Series

Introduction

The proven design of the T Series precision linear actuators has found its way into thousands of applications throughout the world. Precision-rolled ball screws provide smooth motion, accurate positioning and quiet operation, while the slide guide bushings and the rugged exterior design allow it to be used in the toughest applications. The T Series combines durability, performance and ease of use with a large selection of factory engineered options and accessories. The RediMount™ motor mounting adapter kit is available as a standard feature, making it easy to find a suitable motor as well as making the installation of it simple, quick and accurate. Regardless of the environment or requirement, we can customize our standard models to fit just about any application.



T Series

Overview

Features

- Thomson RediMount™ motor mounting adapter kit available as standard
- Extruded, anodized aluminum cover tube
- Anodized aluminum housing
- Hard-chromed steel extension tube
- Can be installed in all directions
- Ball screw drive
- Slide guides
- Load up to 60 000 N
- IP65 protection class
- Washdown-protected versions
- Mounting accessories according to hydraulic cylinder standards available

Parameter		T60	T90	T130
Profile size (width × height)	[mm]	75 × 60	90 × 92	130 × 130
Stroke length (S), maximum	[mm]	1500	1500	2000
Speed, maximum	[m/s]	2,5	2,0	2,0
Dynamic Load (Fx), maximum	[N]	10 000	20 000	60 000
Page		14	16	18

Definition of Forces

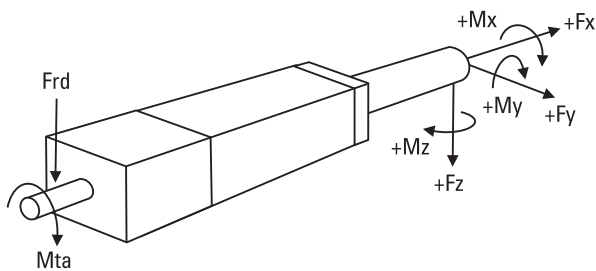



T60

Ball Screw Drive, Slide Guide



- » Ordering Key - see page 74
- » Mounting Options - see page 50
- » Adapter Options - see page 54
- » Glossary - see page 79
- » Dimensions for units w/o RediMount - see page 71

Standard Features and Benefits

- Compact, robust and reliable
- High-accuracy ball screw drive
- Stroke up to 1500 mm
- Load up to 10 000 N
- Speed up to 2,5 m/s
- Hard-chromed steel extension tube
- IP65 as standard
- Mounting accessories according to hydraulic cylinder standards available

General Specifications

Parameter	T60
Profile size (w × h) [mm]	75 × 60
Type of screw	ball screw with single nut
Protection class	IP65
Lubrication	one point lubrication of ballscrew
Included accessories	–

Rod Idle Torque (M_{idle}) [Nm]

Input speed [rpm]	Screw lead (p) [mm]			
	p = 5	p = 10	p = 25	p = 50
500	1,5	1,5	2	3,5

M_{idle} = the input torque needed to move the rod with no load on it.

Performance Specifications

Parameter		T60
Stroke length (S max), maximum	[mm]	1500
Linear speed, maximum	[m/s]	2,5
Acceleration, maximum	[m/s ²]	20
Repeatability	[± mm]	0,05
Input speed, maximum	[rpm]	screw diameter/lead 25/10, 25/25
		screw diameter/lead 25/05, 25/50
Operation temperature limits	[°C]	-20 – 70
Dynamic load (F _x), maximum	[N]	10000
Dynamic load (F _y), maximum	[N]	100
Dynamic load (F _z), maximum	[N]	100
Dynamic load torque (M _z , M _y), max.	[Nm]	50
Drive shaft force (F _{rd}), maximum	[N]	1000
Drive shaft torque/input torque (M _{ta}), max.	[Nm]	T06-B25
		T06-G25
		T06-H25
Screw versions, diameter (d ₀) / lead (p)	[mm]	25/05, 25/10, 25/25, 25/50
Weight of units	[kg]	of unit with zero stroke
		of every 100 mm of stroke

¹ Value for the complete unit

T60

Ball Screw Drive, Slide Guide

Dimensions	Projection
METRIC	

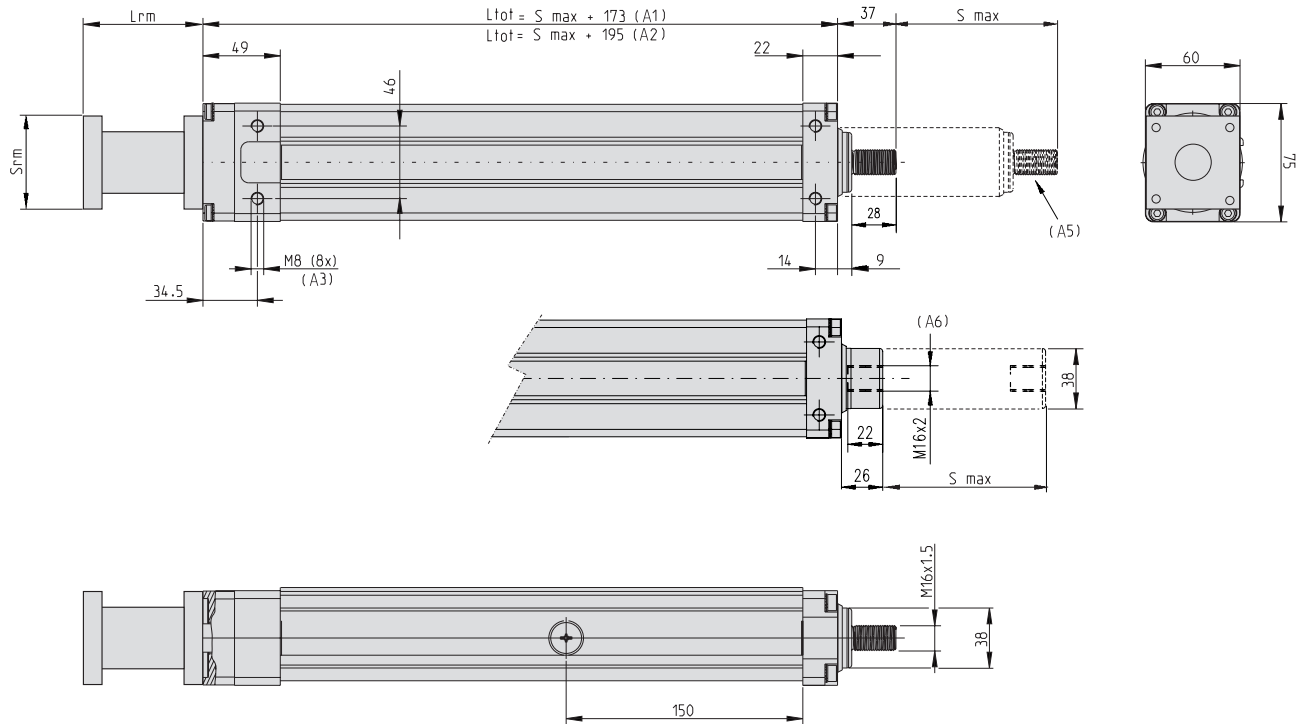

- A1: screw 25/05 and 25/25
- A2: screw 25/10 and 25/50
- A3: depth 10
- A4: outside thread
- A5: inside thread

RediMount Flange Specifications

Parameter		Min	Max
Flange length (Lrm)	[mm]	81	143
Flange square (Srm)	[mm]	90	200
Flange weight *	[kg]	5,60	

* Max. weight including coupling and fastening screws



T90

Ball Screw Drive, Slide Guide



» Ordering Key - see page 74
 » Mounting Options - see page 50
 » Adapter Options - see page 54
 » Glossary - see page 79
 » Dimensions for units w/o RediMount - see page 71

Standard Features and Benefits

- Compact, robust and reliable
- High-accuracy ball screw drive
- Stroke up to 1500 mm
- Load up to 20000 N
- Speed up to 2 m/s
- Hard-chromed steel extension tube
- IP65 as standard
- Mounting accessories according to hydraulic cylinder standards available.

General Specifications

Parameter	T90
Profile size (w × h) [mm]	90 × 92
Type of screw	ball screw with single nut
Protection class	IP65
Lubrication	one point lubrication of ballscrew
Included accessories	–

Rod Idle Torque (M_{idle}) [Nm]

Input speed [rpm]	Screw lead (p) [mm]				
	p = 5	p = 10	p = 20	p = 25	p = 32
500	1,5	1,5	3,0	2,0	3,5

M_{idle} = the input torque needed to move the rod with no load on it.

Performance Specifications

Parameter		T90
Stroke length (S max), maximum	[mm]	1500
Linear speed, maximum	[m/s]	2,0
Acceleration, maximum	[m/s ²]	8
Repeatability	[± mm]	0,05
Input speed, maximum	[rpm]	
screw diam./lead 25/05 mm		3000
screw diam./lead 25/10, 25/25 mm		4000
screw diam./lead 32/10, 32/20, 32/32 mm		3750
Operation temperature limits	[°C]	-20 – 70
Dynamic load (F _x), maximum	[N]	
screw diameter 25 mm		10000
screw diameter 32 mm		20000
Dynamic load (F _y), maximum	[N]	
screw diameter 25 mm		300 ¹
screw diameter 32 mm		500 ¹
Dynamic load (F _z), maximum	[N]	
screw diameter 25 mm		300 ¹
screw diameter 32 mm		500 ¹
Dynamic load torque (M _z , M _y), max.	[Nm]	150 ¹
Drive shaft force (F _{rd}), maximum	[N]	
screw diameter 25 mm		1000
screw diameter 32 mm		1300
Drive shaft torque/input torque (M _{ta}), max.	[Nm]	
screw diameter 25 mm		48
screw diameter 32 mm		93
Screw versions, diameter (d ₀) / lead (p)	[mm]	25/05, 25/10, 25/25, 32/10, 32/20, 32/32
Weight of units with screw diameter 25 mm of unit with zero stroke of every 100 mm of stroke	[kg]	8,16 1,62
Weight of units with screw diameter 32 mm of unit with zero stroke of every 100 mm of stroke	[kg]	10,64 1,80

¹ Value for the complete unit

T90

Ball Screw Drive, Slide Guide

T09-x25
screw ø25 mm

Dimensions	Projection
METRIC	

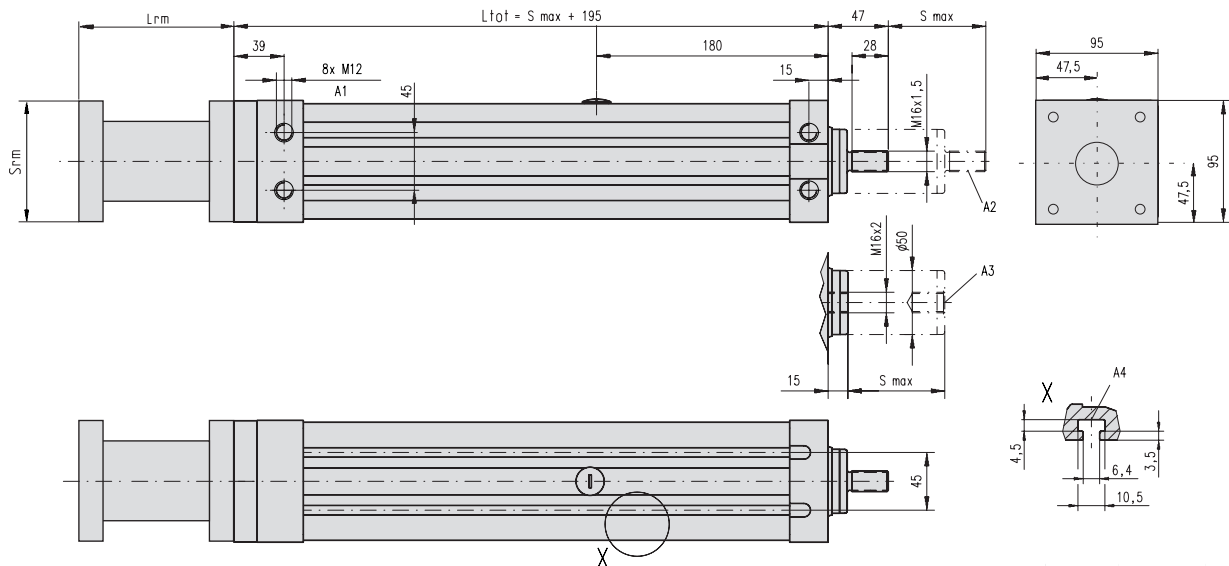

A1: depth 33
A2: outside thread
A3: inside thread
A4: T-slot

RediMount Flange Specifications

Parameter	Min	Max
Flange length (Lrm)	[mm]	81 143
Flange square (Srm)	[mm]	90 200
Flange weight *	[kg]	5,60

* Max. weight including coupling and fastening screws

T09-x32
screw ø32 mm

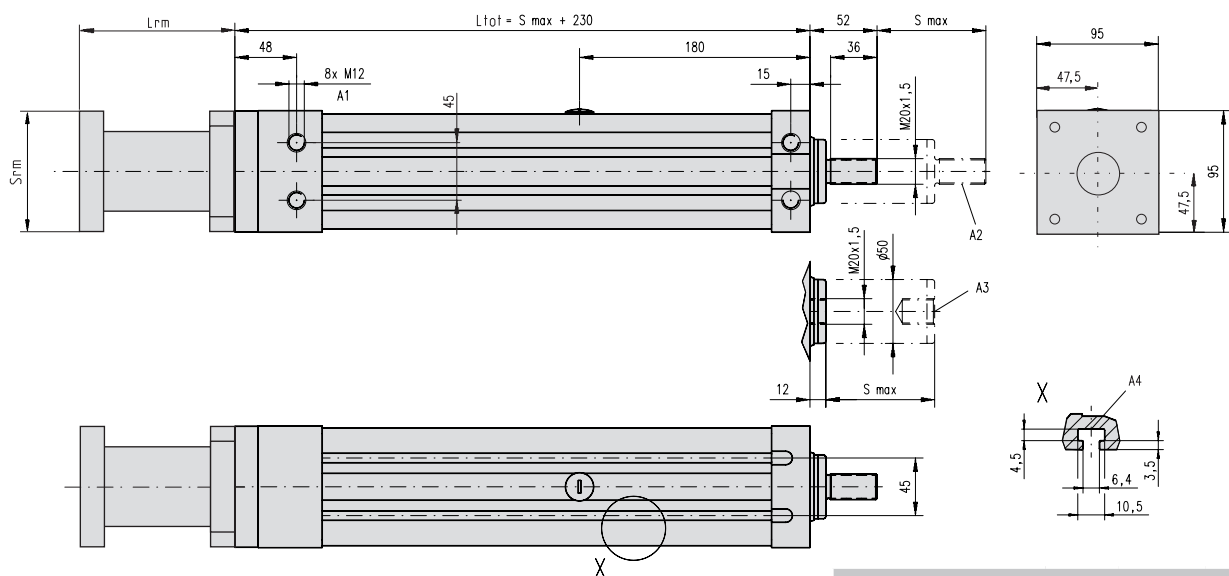

A1: depth 43
A2: outside thread
A3: inside thread
A4: T-slot

RediMount Flange Specifications

Parameter	Min	Max
Flange length (Lrm)	[mm]	81 143
Flange square (Srm)	[mm]	90 200
Flange weight *	[kg]	6,00

* Max. weight including coupling and fastening screws



T130

Ball Screw Drive, Slide Guide

- » Ordering Key - see page 74
- » Mounting Options - see page 50
- » Adapter Options - see page 54
- » Glossary - see page 79
- » Dimensions for units w/o RediMount - see page 72



Standard Features and Benefits

- Compact, robust and reliable
- High-accuracy ball screw drive
- Stroke up to 2000 mm
- Load up to 60000 N
- Speed up to 2 m/s
- Hard-chromed steel extension tube
- IP65 as standard
- Mounting accessories according to hydraulic cylinder standards available.

General Specifications

Parameter	T130
Profile size (w × h) [mm]	130 × 130
Type of screw	ball screw with single nut
Protection class	IP65
Lubrication	one point lubrication of ballscrew
Included accessories	–

Rod Idle Torque (M_{idle}) [Nm]

Input speed [rpm]	Screw diameter (do) [mm] / lead (p) [mm]			
	do = 40			do = 50
	p = 10	p = 20	p = 40	p = 10
500	4,5	4,5	5,5	5,5

M_{idle} = the input torque needed to move the rod with no load on it.

Performance Specifications

Parameter	T130
Stroke length (S max), maximum [mm]	2000
Linear speed, maximum [m/s]	2,0
Acceleration, maximum [m/s ²]	8
Repeatability [± mm]	0,05
Input speed, maximum [rpm]	
screw diameter/lead 40/10 mm	2500
screw diameter/lead 40/20, 40/40 mm	3000
screw diameter/lead 50/10 mm	2000
Operation temperature limits [°C]	- 20 – 70
Dynamic load (Fx), maximum [N]	
screw diameter/lead 50/10 mm	60000
screw diameter/lead 40/10 mm	40000
screw diameter/lead 40/20 mm	35000
screw diameter/lead 40/40 mm	15000
Dynamic load (Fy), maximum [N]	800 ¹
Dynamic load (Fz), maximum [N]	800 ¹
Dynamic load torque (My, Mz), max. [Nm]	300 ¹
Drive shaft force (Frd), maximum [N]	3000
Drive shaft torque/input torque (Mta), max. [Nm]	
T13-x40	140
T13-B50	200
T13-K50	140
Screw versions, diameter (do) / lead (p) [mm]	40/10, 40/20, 40/40, 50/10
Weight of units [kg]	
with screw diameter 40 mm	
of unit with zero stroke	18,50
of every 100 mm of stroke	3,00
with screw diameter 50 mm	
of unit with zero stroke	25,40
of every 100 mm of stroke	3,60

¹ Value for the complete unit

T130

Ball Screw Drive, Slide Guide

T13-x40
screw $\varnothing 40$ mm

Dimensions	Projection
METRIC	

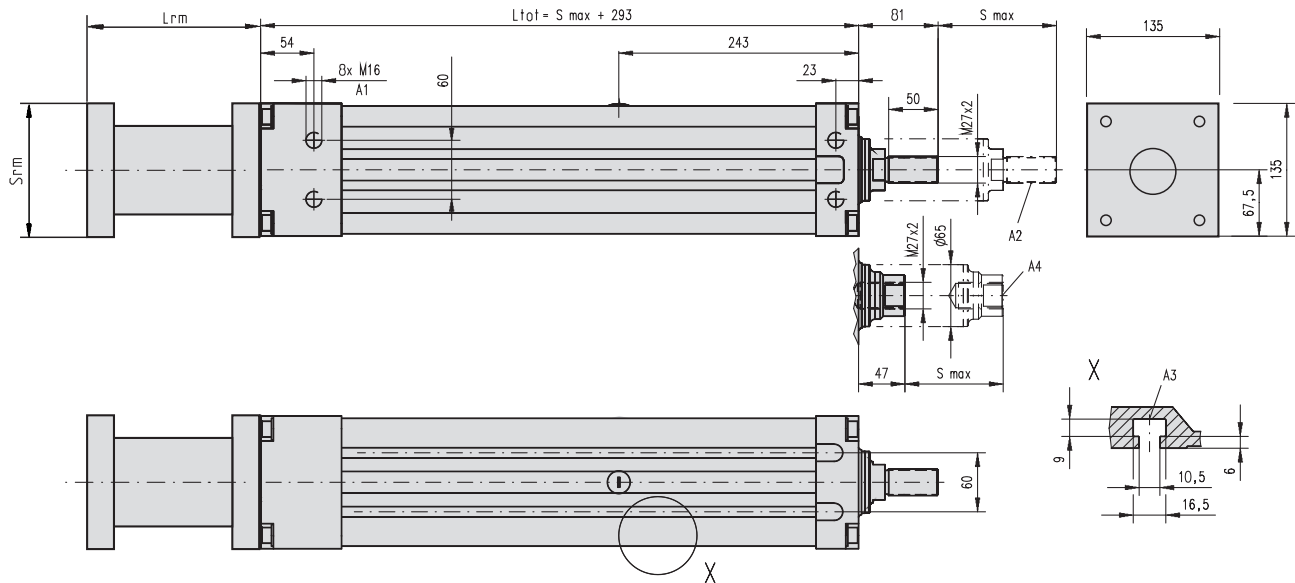

A1: depth 28
A2: outside thread

A3: T-slot
A4: inside thread

RediMount Flange Specifications

Parameter	Min	Max
Flange length (Lrm) [mm]	81	143
Flange square (Srm) [mm]	90	200
Flange weight * [kg]	6,50	

* Max. weight including coupling and fastening screws

T13-x50
screw $\varnothing 50$ mm

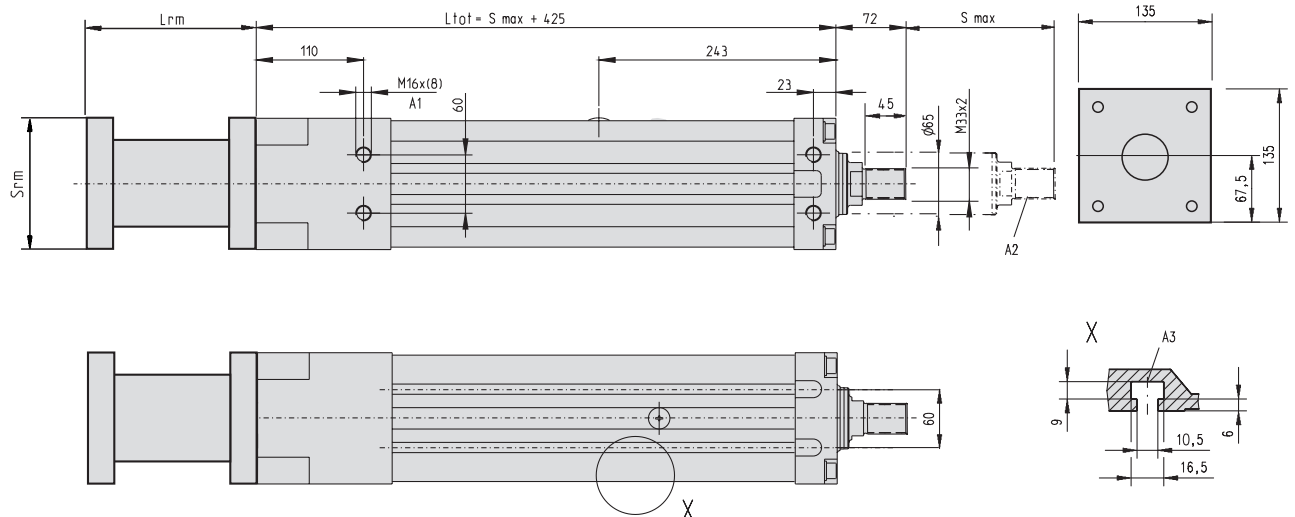

A1: depth 28
A2: outside thread

A3: T-slot

RediMount Flange Specifications

Parameter	Min	Max
Flange length (Lrm) [mm]	106	154
Flange square (Srm) [mm]	110	200
Flange weight * [kg]	7,13	

* Max. weight including coupling and fastening screws



ECT Series

Introduction

The ECT Series is our line of packaged precision linear actuators. They are based on the proven T Series and equipped with a high-quality selection of motors and gears that make them ready to take on the most demanding applications. The ECT Series is ideal when short design times, maximum performance and the longest lifecycle are required. And if you can't find a standard unit that fits, our engineers can build you a customized unit to suit your needs.

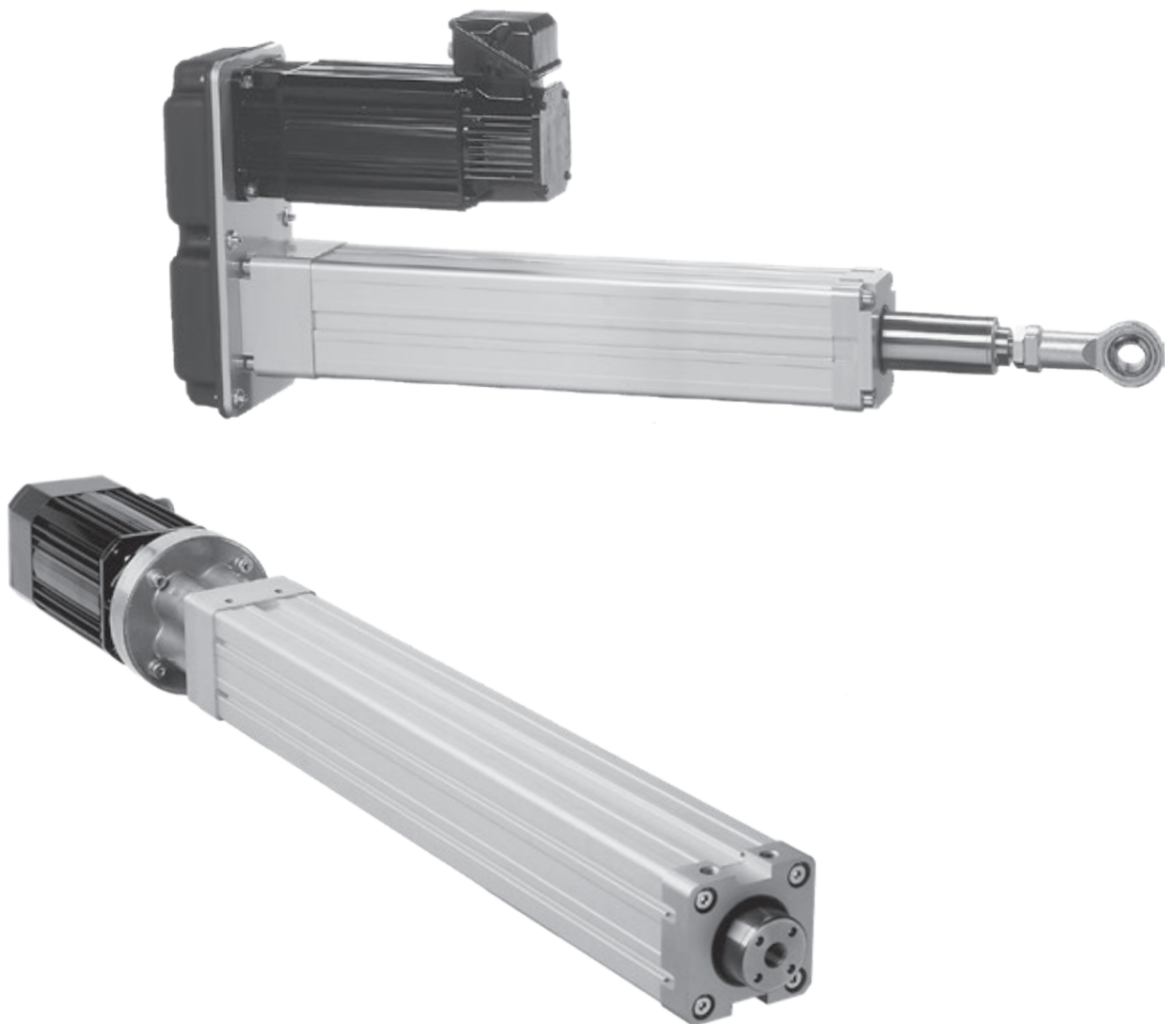

ECT Series

Overview

Features

- Extruded, anodized aluminum cover tube
- Anodized aluminum housing
- Hard-chromed steel extension tube
- Can be installed in all directions
- Ball screw drive
- Slide guides
- Load up to 38000 N
- Asynchronous, three-phase AC motor or brushless AC servo motor
- Parallel or inline motor
- Belt gear, planetary gear or direct drive
- IP65 as standard
- Large range of options and accessories
- Wash-down-protected versions
- Mounting accessories according to hydraulic cylinder standards available

Parameter		ECT90	ECT130
Profile size (width × height)	[mm]	90 × 92	130 × 130
Stroke length (S), maximum	[mm]	1500	2000
Speed, maximum	[mm/s]	1600	2000
Dynamic load (Fx), maximum	[N]	20 000	38 000
Page		22 - 35	36 - 49

Definition of Forces

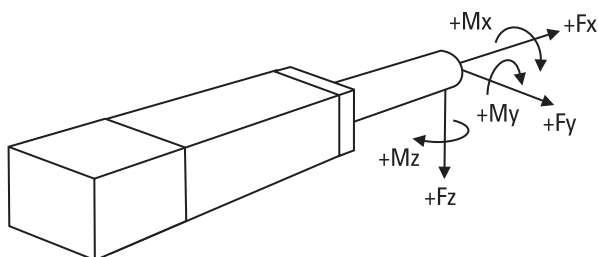



ECT90

Parallel IEC90 AC Motor

- » Ordering Key - see page 75
- » Mounting Options - see page 50
- » Adapter Options - see page 54
- » Glossary - see page 79



Standard Features and Benefits

- Robust and reliable
- Three-phase, asynchronous AC motor with brake
- Belt gear
- Ball screw
- Hard-chromed steel extension tube
- IP65 as standard
- Stroke up to 1500 mm
- Load up to 9750 N
- Speed up to 1520 mm/s

General Specifications

Parameter	ECT90
Profile size (w × h)	90 × 92 mm
Screw type	ball screw
Gear box	belt gear
Motor type	asynchronous AC motor
Motor voltage	3 × 400 Vac
Motor power	2,2 kW
Motor current, nominal	4,7 A
Motor feedback	no
Motor connection	terminal box
Motor brake	yes (230 Vac)
Lubrication	single point lubrication
Certificates	CE
Options	<ul style="list-style-type: none"> • mounting options • adapter options

Performance Specifications

Parameter	ECT90
Stroke length (S), maximum [mm]	1500
Maximum dynamic load (Fx) ¹ [N]	
ECT09-I09B03PB-2510	9750
ECT09-I09B02PB-2510	6500
ECT09-I09B03PB-3220	4800
ECT09-I09B02PB-3220	3100
ECT09-I09B01PB-3220	1600
ECT09-I09B01PB-3232	900
Maximum load (Fy, Fz) ² [N]	500
Maximum load torque (My, Mz) [Nm]	150
Maximum speed ³ [mm/s]	
ECT09-I09B03PB-2510	160
ECT09-I09B02PB-2510	240
ECT09-I09B03PB-3220	320
ECT09-I09B02PB-3220	480
ECT09-I09B01PB-3220	960
ECT09-I09B01PB-3232	1520
Operating temperature limits [°C]	-20 – 70
Screw diameters [mm]	25, 32
Screw leads ⁴ [mm]	10, 20, 32
Backlash [mm]	
Screw diameter = 25 mm	0,11
Screw diameter = 32 mm	0,18
Repeatability [± mm]	0,05
Protection class, standard	IP65

¹ At a 100% duty cycle.

² Value at full retraction - decreases as the actuator extends.

³ The maximum speed is based on a max. input frequency to the motor of 50 Hz. Frequency inverters can provide higher frequencies thus higher speeds but that may damage the actuator.

⁴ 10 mm lead = diameter 25 mm. 20 and 32 mm leads = diameter 32 mm.

ECT90

Parallel IEC90 AC Motor

Dimensions	Projection
METRIC	

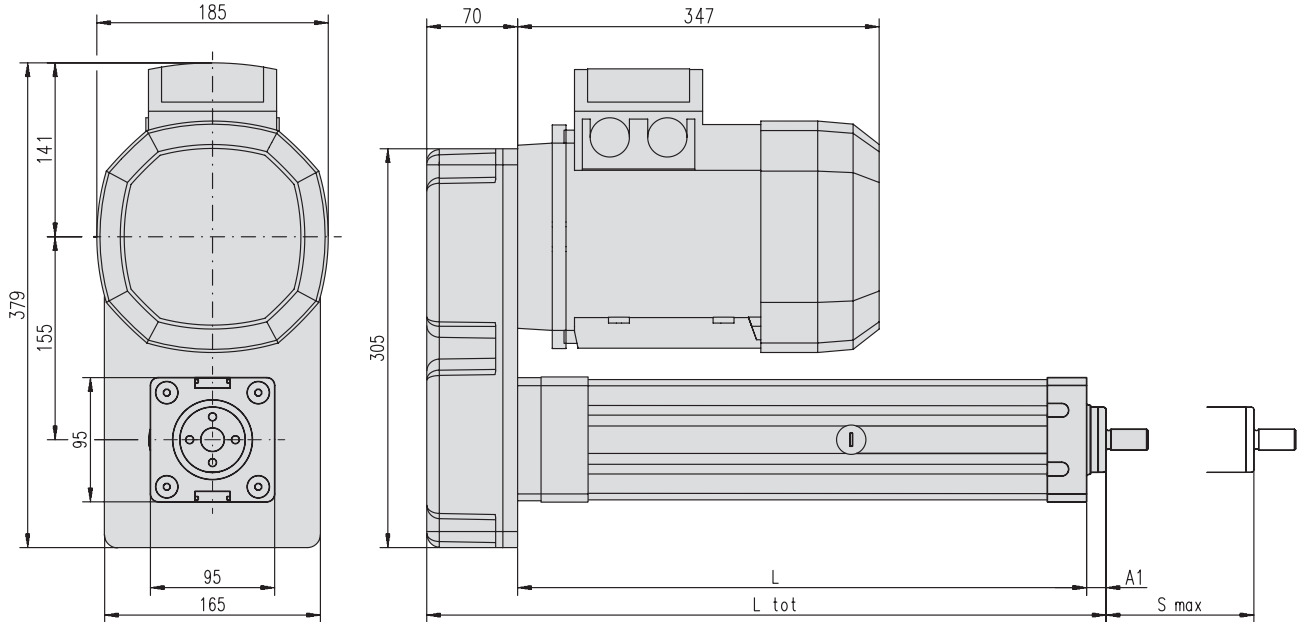

S max: maximum stroke (ordering stroke in mm)
L: cover tube length

L tot: retracted length
A1: ECT09-I09B • • PB-25 = 15 mm, ECT09-I09B • • PB-32 = 12 mm

Cover tube length (L)	[mm]	ECT09-I09BxxPB-25: $L = S_{max} + 195$ ECT09-I09BxxPB-32: $L = S_{max} + 230$
Retracted length (L tot)	[mm]	ECT09-I09BxxPB-25: $L_{tot} = S_{max} + 280$ ECT09-I09BxxPB-32: $L_{tot} = S_{max} + 312$
Weight of unit	[kg]	ECT09-I09BxxPB-25: $kg = 30,8 + 0,016 \times S_{max}$ ECT09-I09BxxPB-32: $kg = 33,2 + 0,018 \times S_{max}$

Performance Diagrams

Speed vs. Load

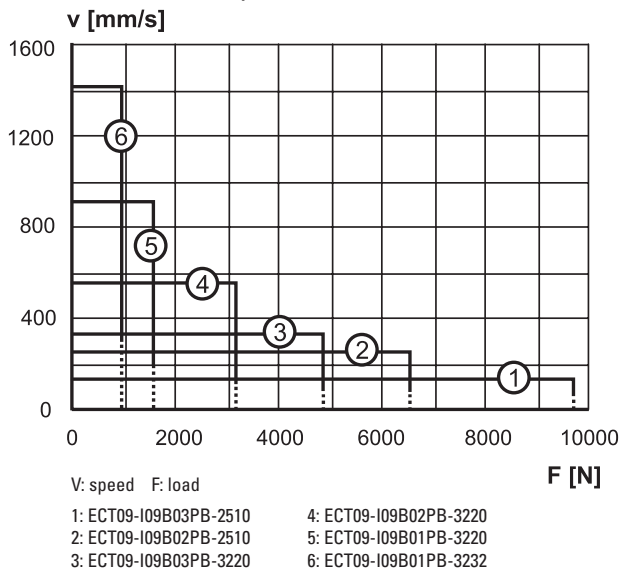

Critical Speed vs. Stroke

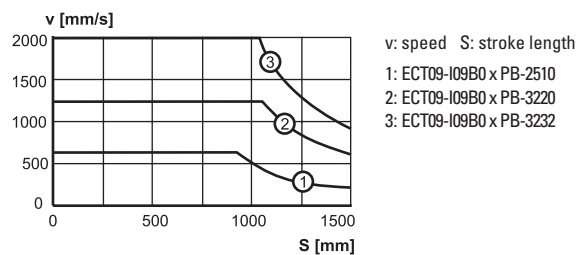

Column Load Limit vs. Stroke

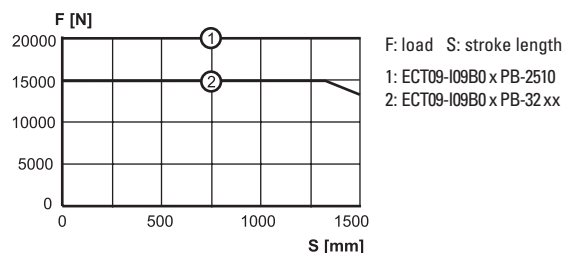

..... = Overheating of the motor may occur if running at this speed continuously!



ECT90

Parallel B43 AC Servo Motor

- » Ordering Key - see page 75
- » Mounting Options - see page 50
- » Adapter Options - see page 54
- » Glossary - see page 79



Standard Features and Benefits

- Robust and reliable
- Brushless AC servo motor
- Belt gear
- Ball screw
- Hard-chromed steel extension tube
- IP65 as standard
- Stroke up to 1500 mm
- Load up to 5800 N
- Speed up to 420 mm/s

General Specifications

Parameter	ECT90
Profile size (w × h)	90 × 92 mm
Screw type	ball screw
Gear box	belt gear
Motor type	brushless AC servo motor
Motor designation	AKM43E-ANCNR-00
Motor feedback	resolver
Motor connection	connector
Motor brake	no, optional
Lubrication	single point lubrication
Certificates	CE
Options	<ul style="list-style-type: none"> • motor brake (24 Vdc) • mounting options • adapter options

Performance Specifications

Parameter	ECT90
Stroke length (S), maximum [mm]	1500
Maximum dynamic load (Fx) ¹ [N]	ECT09-B43R03PB-2510 5800 ECT09-B43R02PB-2510 3800 ECT09-B43R03PB-3220 2800 ECT09-B43R02PB-3220 1800
Maximum load (Fy, Fz) ² [N]	500
Maximum load torque (My, Mz) [Nm]	150
Maximum speed [mm/s]	ECT09-B43R03PB-2510 140 ECT09-B43R02PB-2510 210 ECT09-B43R03PB-3220 270 ECT09-B43R02PB-3220 420
Operating temperature limits [°C]	-20 – 70
Screw diameters [mm]	25, 32
Screw leads ³ [mm]	10, 20
Backlash [mm]	Screw diameter = 25 mm 0,11 Screw diameter = 32 mm 0,18
Repeatability [± mm]	0,05
Protection class, standard	IP65

¹ At a 100% duty cycle.

² Value at full retraction - decreases as the actuator extends.

³ 10 mm lead = diameter 25 mm. 20 mm lead = diameter 32 mm.

ECT90

Parallel B43 AC Servo Motor

Dimensions	Projection
METRIC	

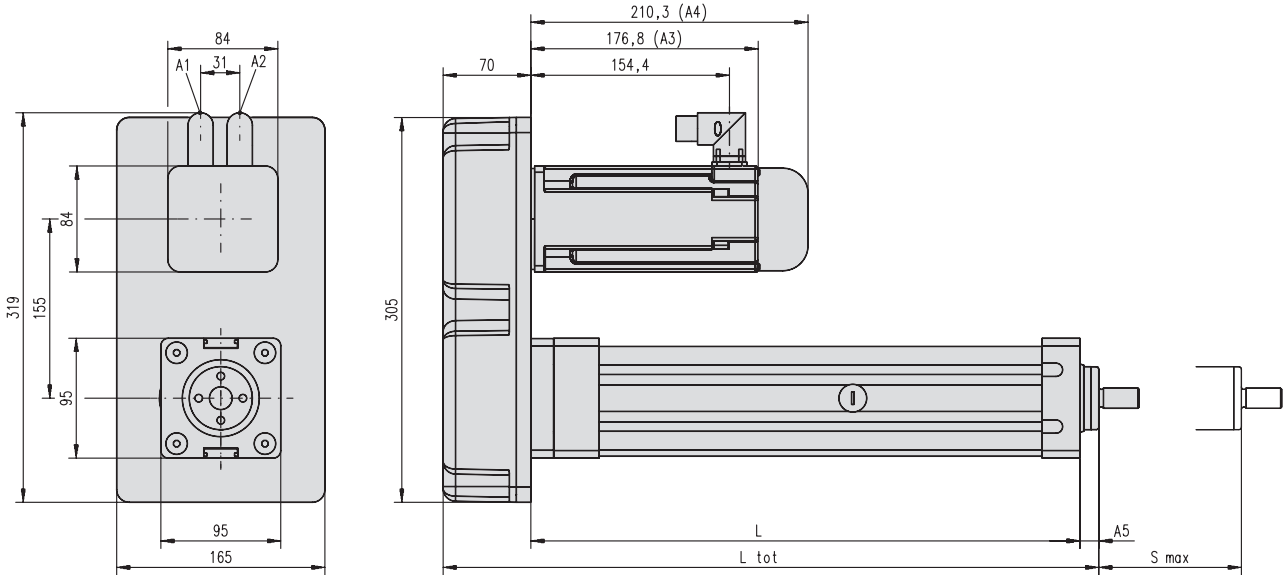

S max: maximum stroke (ordering stroke in mm)
 L: cover tube length
 L tot: retracted length

A1: power connector
 A2: resolver connector
 A3: without brake

A4: with brake
 A5: ECT09-B43•••PB-25 = 15 mm, ECT09-B43•••PB-32 = 12 mm

Cover tube length (L)	[mm]	ECT09-B43 xxx PB-25: L = S max + 195 ECT09-B43 xxx PB-32: L = S max + 230
Retracted length (L tot)	[mm]	ECT09-B43 xxx PB-25: L tot = S max + 280 ECT09-B43 xxx PB-32: L tot = S max + 312
Weight of unit	[kg]	ECT09-B43 xx PB-25: kg = 17,2 + 0,016 × S max ECT09-B43 xx PB-32: kg = 19,6 + 0,018 × S max

Performance Diagrams

Speed vs. Load

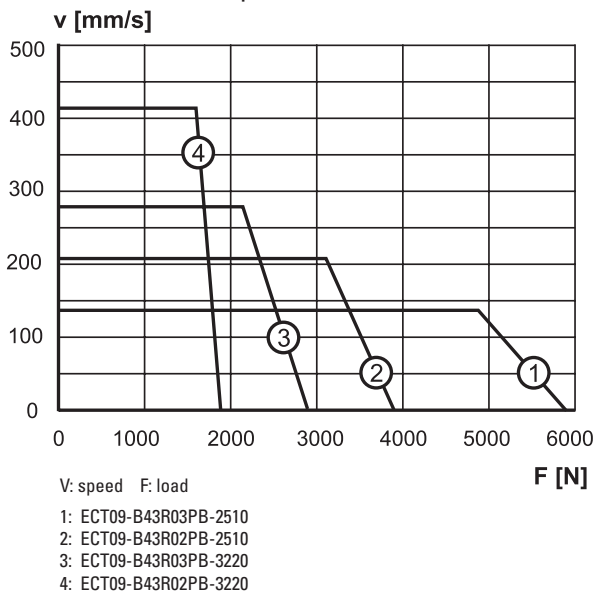

Critical Speed vs. Stroke

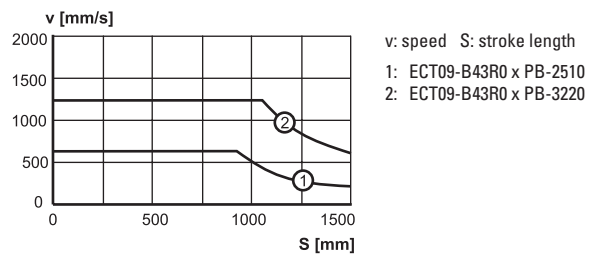

Column Load Limit vs. Stroke

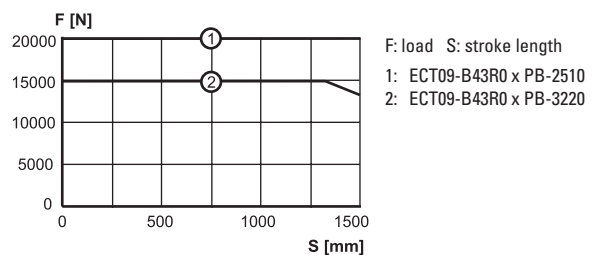



ECT90

Parallel B53 AC Servo Motor

- » Ordering Key - see page 75
- » Mounting Options - see page 50
- » Adapter Options - see page 54
- » Glossary - see page 79



Standard Features and Benefits

- Robust and reliable
- Brushless AC servo motor
- Belt gear
- Ball screw
- Hard-chromed steel extension tube
- IP65 as standard
- Stroke up to 1500 mm
- Load up to 9800 N
- Speed up to 670 mm/s

General Specifications

Parameter	ECT90
Profile size (w × h)	90 × 92 mm
Screw type	ball screw
Gear box	belt gear
Motor type	brushless AC servo motor
Motor designation	AKM53K-CNCNR-00
Motor feedback	resolver
Motor connection	connector
Motor brake	no, optional
Lubrication	single point lubrication
Certificates	CE
Options	<ul style="list-style-type: none"> • motor brake (24 Vdc) • mounting options • adapter options

Performance Specifications

Parameter	ECT90
Stroke length (S), maximum [mm]	1500
Maximum dynamic load (Fx) ¹ [N]	ECT09-B53R03PB-2510 9800 ECT09-B53R02PB-2510 8000 ECT09-B53R03PB-3220 5900 ECT09-B53R02PB-3220 3900
Maximum load (Fy, Fz) ² [N]	500
Maximum load torque (My, Mz) [Nm]	150
Maximum speed [mm/s]	ECT09-B53R03PB-2510 220 ECT09-B53R02PB-2510 330 ECT09-B53R03PB-3220 440 ECT09-B53R02PB-3220 670
Operating temperature limits [°C]	-20 – 70
Screw diameters [mm]	25, 32
Screw leads ³ [mm]	10, 20
Backlash [mm]	Screw diameter = 25 mm 0,11 Screw diameter = 32 mm 0,18
Repeatability [± mm]	0,05
Protection class, standard	IP65

¹ At a 100% duty cycle.

² Value at full retraction - decreases as the actuator extends.

³ 10 mm lead = diameter 25 mm. 20 mm lead = diameter 32 mm.

ECT90

Parallel B53 AC Servo Motor

Dimensions	Projection
METRIC	

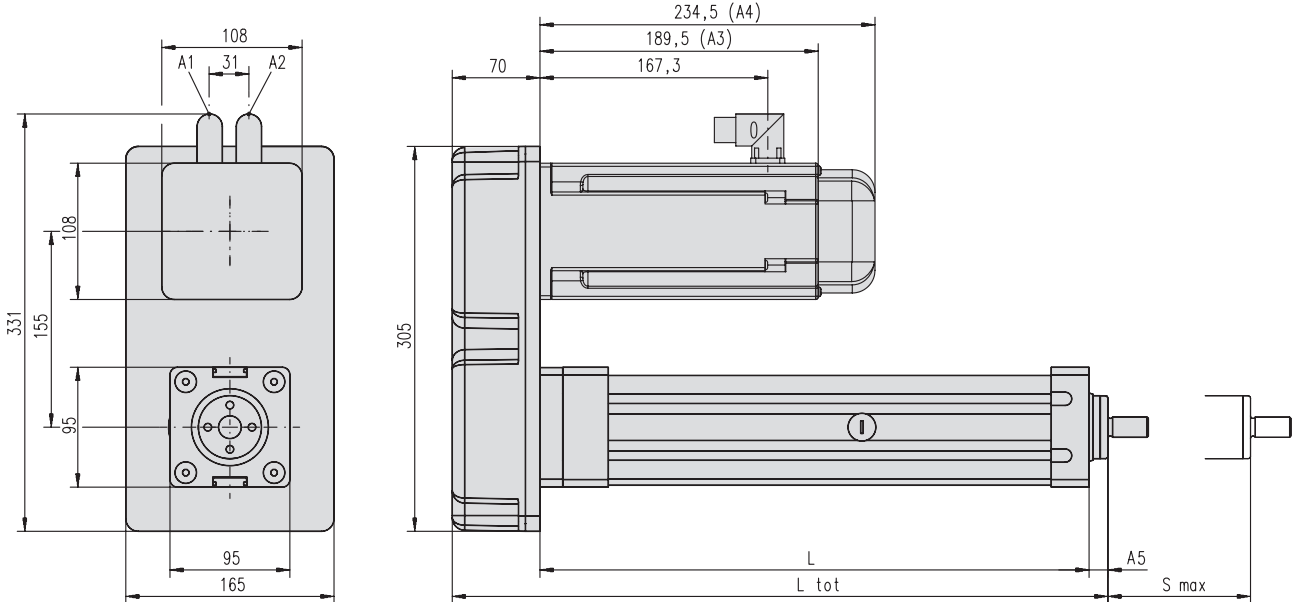

S max: maximum stroke (ordering stroke in mm)
 L: cover tube length
 L tot: retracted length

A1: power connector
 A2: resolver connector
 A3: without brake

A4: with brake
 A5: ECT09-B53 ••• PB-25 = 15 mm, ECT09-B53 ••• PB-32 = 12 mm

Cover tube length (L)	[mm]	ECT09-B53 xxx PB-25: $L = S_{max} + 195$ ECT09-B53 xxx PB-32: $L = S_{max} + 230$
Retracted length (L tot)	[mm]	ECT09-B53 xxx PB-25: $L_{tot} = S_{max} + 280$ ECT09-B53 xxx PB-32: $L_{tot} = S_{max} + 312$
Weight of unit	[kg]	ECT09-B53 xx PB-25: $kg = 20,2 + 0,016 \times S_{max}$ ECT09-B53 xx PB-32: $kg = 22,6 + 0,018 \times S_{max}$

Performance Diagrams

Speed vs. Load

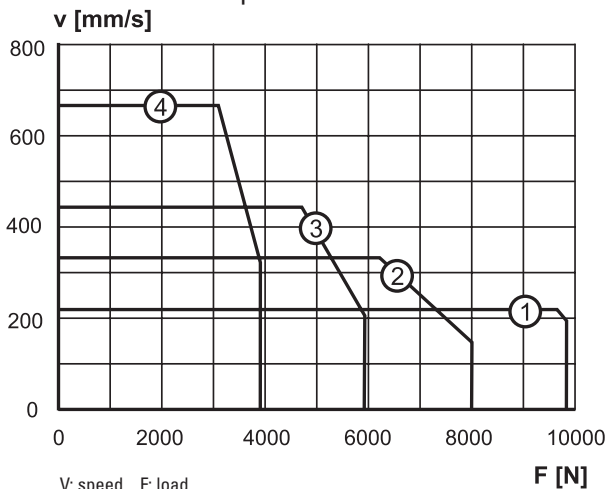

V: speed F: load
 1: ECT09-B53R03PB-2510
 2: ECT09-B53R02PB-2510
 3: ECT09-B53R03PB-3220
 4: ECT09-B53R02PB-3220

Critical Speed vs. Stroke

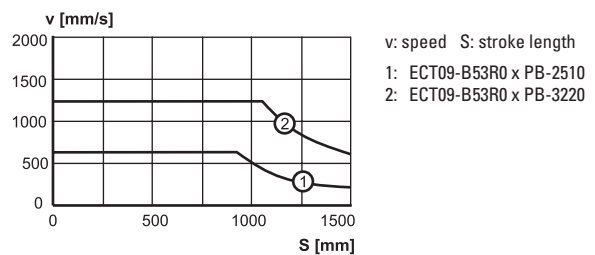

v: speed S: stroke length
 1: ECT09-B53R0 x PB-2510
 2: ECT09-B53R0 x PB-3220

Column Load Limit vs. Stroke

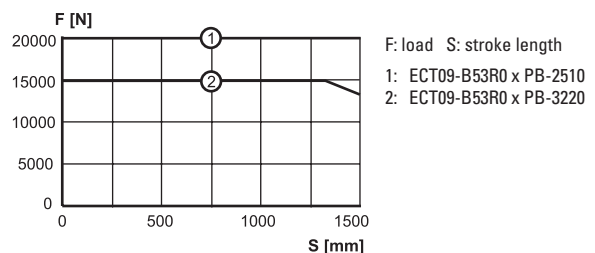

F: load S: stroke length
 1: ECT09-B53R0 x PB-2510
 2: ECT09-B53R0 x PB-3220



ECT90

Direct Drive, Inline B43 AC Servo Motor

- » Ordering Key - see page 76
- » Mounting Options - see page 50
- » Adapter Options - see page 54
- » Glossary - see page 79



Standard Features and Benefits

- Robust and reliable
- Brushless AC servo motor
- Direct drive
- Ball screw
- Hard-chromed steel extension tube
- IP65 as standard
- Stroke up to 1500 mm
- Load up to 5300 N
- Speed up to 1600 mm/s

General Specifications

Parameter	ECT90
Profile size (w × h)	90 × 92 mm
Screw type	ball screw
Gear box	no, direct drive
Motor type	brushless AC servo motor
Motor designation	AKM43E-ANCNR-00
Motor feedback	resolver
Motor connection	connector
Motor brake	no, optional
Lubrication	single point lubrication
Certificates	CE
Options	<ul style="list-style-type: none"> • motor brake (24 Vdc) • mounting options • adapter options

Performance Specifications

Parameter	ECT90
Stroke length (S), maximum [mm]	1500
Maximum dynamic load (Fx) ¹ [N]	ECT09-B43R01LD-2510 2000 ECT09-B43R01LD-3220 900
Maximum load (Fy, Fz) ² [N]	500
Maximum load torque (My, Mz) [Nm]	150
Maximum speed [mm/s]	ECT09-B43R01LD-2510 410 ECT09-B43R01LD-3220 820
Operating temperature limits [°C]	-20 – 70
Screw diameters [mm]	25, 32
Screw leads ³ [mm]	10, 20
Backlash [mm]	Screw diameter = 25 mm 0,11 Screw diameter = 32 mm 0,18
Repeatability [± mm]	0,05
Protection class, standard	IP65

¹ At a 100% duty cycle.

² Value at full retraction - decreases as the actuator extends.

³ 10 mm lead = diameter 25 mm. 20 mm lead = diameter 32 mm.

ECT90

Direct Drive, Inline B43 AC Servo Motor

Dimensions	Projection
METRIC	

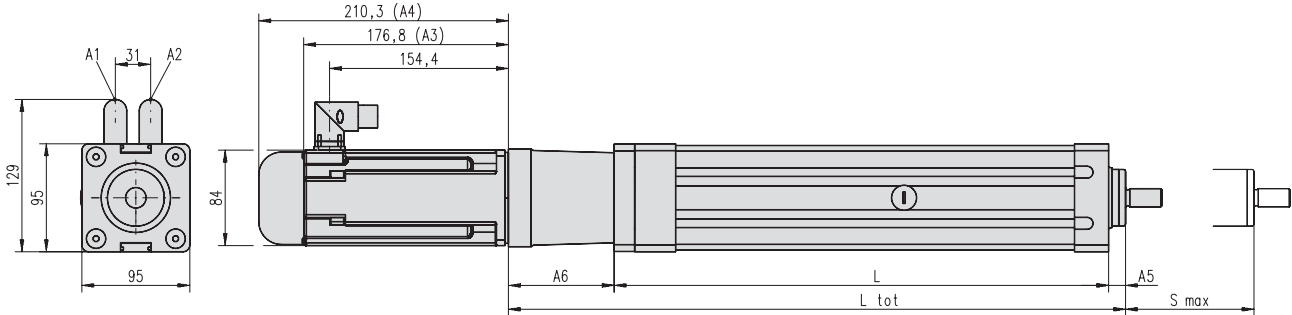

S max: maximum stroke (ordering stroke in mm)
 L: cover tube length
 L tot: retracted length

A1: power connector
 A2: resolver connector
 A3: without brake

A4: with brake
 A5: ECT09-B43 • 01LD-25 = 15 mm, ECT09-B43 • 01LD-32 = 12 mm
 A6: ECT09-B43 • 01LD-25 = 93 mm, ECT09-B43 • 01LD-32 = 103 mm

Cover tube length (L)	[mm]	ECT09-B43 x-B43 • 01LD-32: L = S max + 230
Retracted length (L tot)	[mm]	ECT09-B43 x 01LD-25: L tot = S max + 303 ECT09-B43 x 01LD-32: L tot = S max + 345
Weight of unit	[kg]	ECT09-B43 xx 01LD-25: kg = 13,7 + 0,016 × S max ECT09-B43 xx 01LD-32: kg = 16,2 + 0,018 × S max

Performance Diagrams

Speed vs. Load

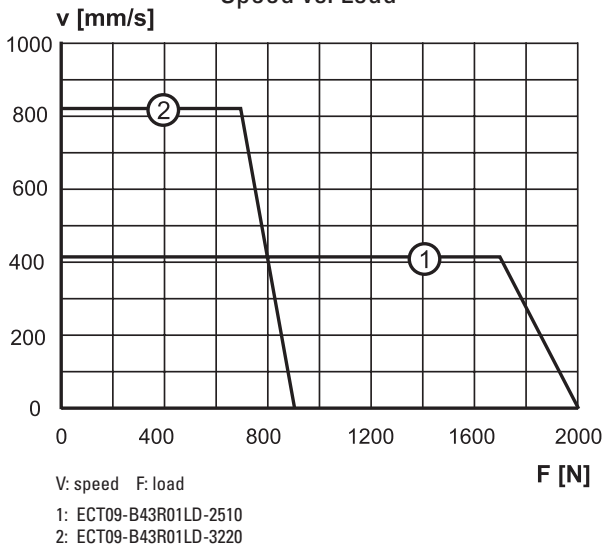

Critical Speed vs. Stroke

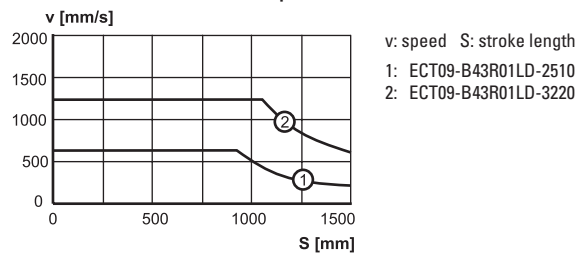

Column Load Limit vs. Stroke

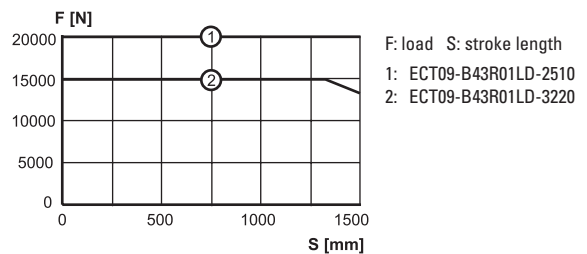



ECT90

Direct Drive, Inline B53 AC Servo Motor

- » Ordering Key - see page 76
- » Mounting Options - see page 50
- » Adapter Options - see page 54
- » Glossary - see page 79



Standard Features and Benefits

- Robust and reliable
- Brushless AC servo motor
- Direct drive
- Ball screw
- Hard-chromed steel extension tube
- IP65 as standard
- Stroke up to 1500 mm
- Load up to 5300 N
- Speed up to 1600 mm/s

General Specifications

Parameter	ECT90
Profile size (w × h)	90 × 92 mm
Screw type	ball screw
Gear box	no, direct drive
Motor type	brushless AC servo motor
Motor designation	AKM53K-ANCNR-00
Motor feedback	resolver
Motor connection	connector
Motor brake	no, optional
Lubrication	single point lubrication
Certificates	CE
Options	<ul style="list-style-type: none"> • motor brake (24 Vdc) • mounting options • adapter options

Performance Specifications

Parameter	ECT90
Stroke length (S), maximum [mm]	1500
Maximum dynamic load (Fx) ¹ [N]	
ECT09-B53R01LD-2510	5300
ECT09-B53R01LD-3220	2600
ECT09-B53R01LD-3232	1500
Maximum load (Fy, Fz) ² [N]	500
Maximum load torque (My, Mz) [Nm]	150
Maximum speed [mm/s]	
ECT09-B53R01LD-2510	450
ECT09-B53R01LD-3220	1000
ECT09-B53R01LD-3232	1600
Operating temperature limits [°C]	-20 – 70
Screw diameters [mm]	25, 32
Screw leads ³ [mm]	10, 20, 32
Backlash [mm]	
Screw diameter = 25 mm	0,11
Screw diameter = 32 mm	0,18
Repeatability [± mm]	0,05
Protection class, standard	IP65

¹ At a 100% duty cycle.

² Value at full retraction - decreases as the actuator extends.

³ 10 mm lead = diameter 25 mm. 20 and 32 mm leads = diameter 32 mm.

ECT90

Direct Drive, Inline B53 AC Servo Motor

Dimensions	Projection
METRIC	

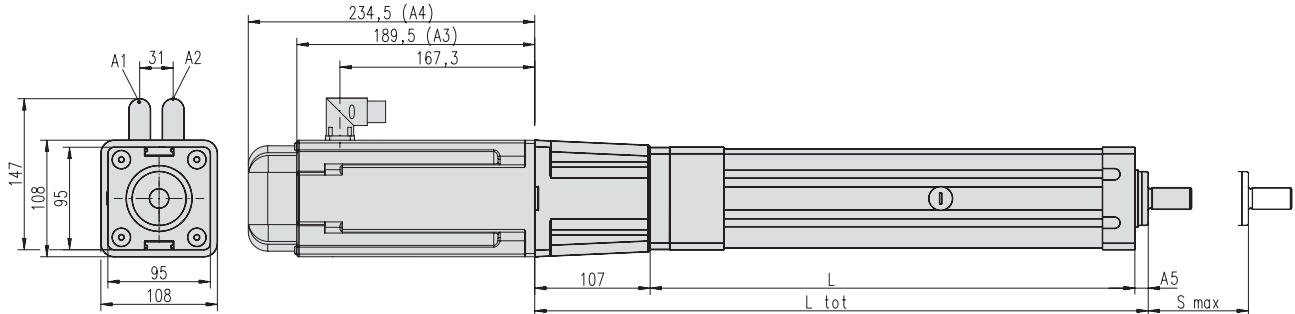

S max: maximum stroke (ordering stroke in mm)
 L: cover tube length
 L tot: retracted length

A1: power connector
 A2: resolver connector
 A3: without brake

A4: with brake
 A5: ECT09-B53 • 01LD-25 = 15 mm, ECT09-B53 • 01LD-32 = 12 mm

Cover tube length (L)	[mm]	ECT09-B53 x 01LD-25: L = S max + 195 ECT09-B53 x 01LD-32: L = S max + 230
Retracted length (L tot)	[mm]	ECT09-B53 x 01LD-25: L tot = S max + 303 ECT09-B53 x 01LD-32: L tot = S max + 344
Weight of unit	[kg]	ECT09-B53 xx 01LD-25: kg = 17,2 + 0,016 × S max ECT09-B53 xx 01LD-32: kg = 19,6 + 0,018 × S max

Performance Diagrams

Speed vs. Load

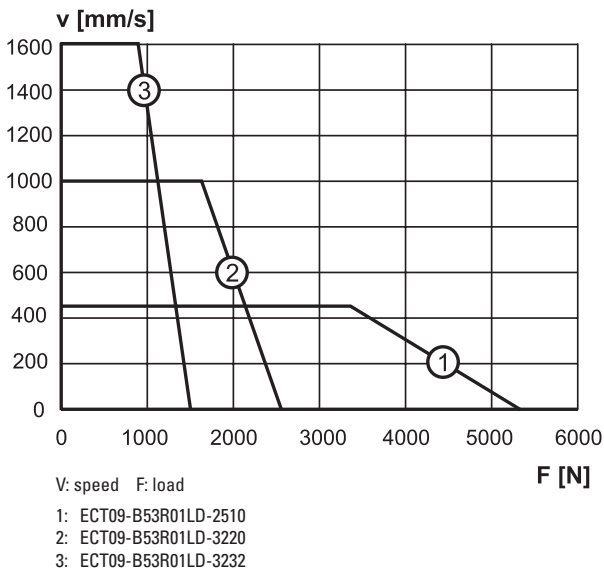

Critical Speed vs. Stroke

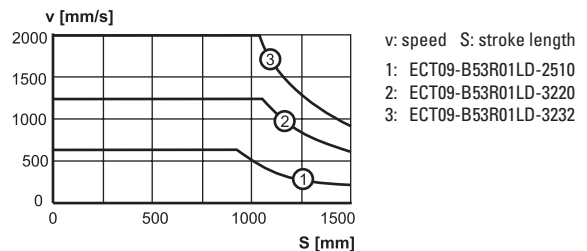

Column Load Limit vs. Stroke

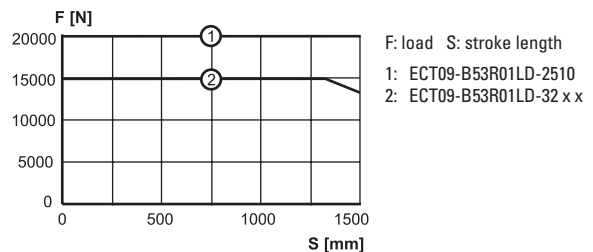



ECT90

Planetary Gear, Inline B43 AC Servo Motor

- » Ordering Key - see page 76
- » Mounting Options - see page 50
- » Adapter Options - see page 54
- » Glossary - see page 79



Standard Features and Benefits

- Robust and reliable
- Brushless AC servo motor
- Planetary gear
- Ball screw
- Hard-chromed steel extension tube
- IP65 as standard
- Stroke up to 1500 mm
- Load up to 10000 N
- Speed up to 160 mm/s

General Specifications

Parameter	ECT90
Profile size (w × h)	90 × 92 mm
Screw type	ball screw
Gear box	planetary gear
Motor type	brushless AC servo motor
Motor designation	AKM43E-ANCNR-00
Motor feedback	resolver
Motor connection	connector
Motor brake	no, optional
Lubrication	single point lubrication
Certificates	CE
Options	<ul style="list-style-type: none"> • motor brake (24 Vdc) • mounting options • adapter options

Performance Specifications

Parameter	ECT90
Stroke length (S), maximum [mm]	1500
Maximum dynamic load (Fx) ¹ [N]	ECT09-B43R10LP-3220 10000 ECT09-B43R05LP-3220 5000
Maximum load (Fy, Fz) ² [N]	500
Maximum load torque (My, Mz) [Nm]	150
Maximum speed [mm/s]	ECT09-B43R10LP-3220 80 ECT09-B43R05LP-3220 160
Operating temperature limits [°C]	-20 – 70
Screw diameters [mm]	32
Screw leads [mm]	20
Backlash [mm]	Screw diameter = 25 mm 0,11 Screw diameter = 32 mm 0,18
Repeatability [± mm]	0,05
Protection class, standard	IP65

¹ At a 100% duty cycle.

² Value at full retraction - decreases as the actuator extends.

ECT90

Planetary Gear, Inline B43 AC Servo Motor

Dimensions	Projection
METRIC	

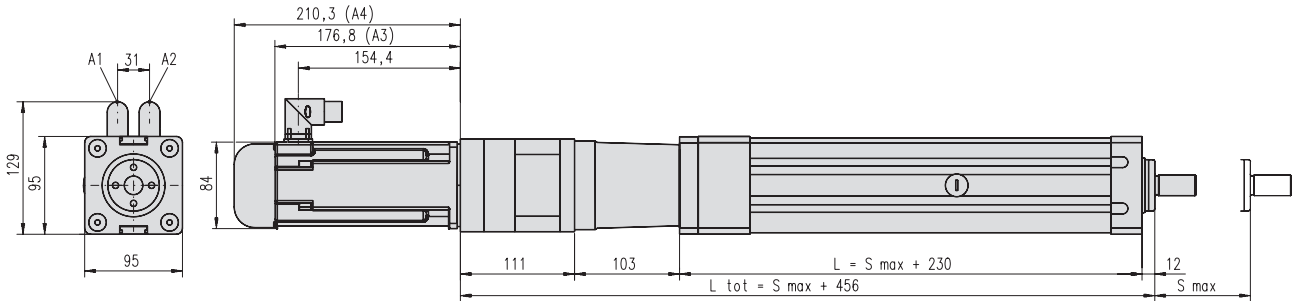

S max: maximum stroke (ordering stroke in mm)
 L: cover tube length
 L tot: retracted length

A1: power connector
 A2: resolver connector
 A3: without brake

A4: with brake

Cover tube length (L)	[mm]	$L = S_{max} + 230$
Retracted length (L tot)	[mm]	$L_{tot} = S_{max} + 456$
Weight of unit	[kg]	$kg = 19,2 + 0,018 \times S_{max}$

Performance Diagrams

Speed vs. Load

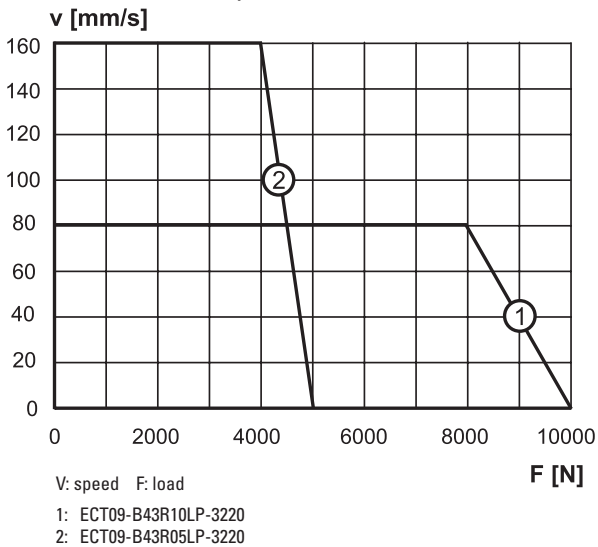

Critical Speed vs. Stroke

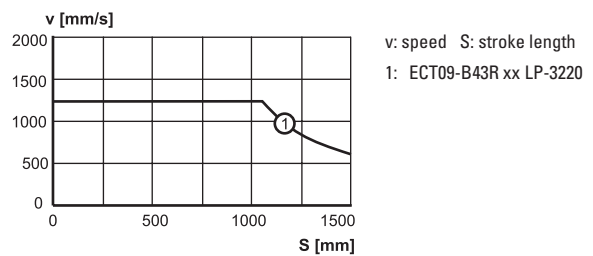

Column Load Limit vs. Stroke

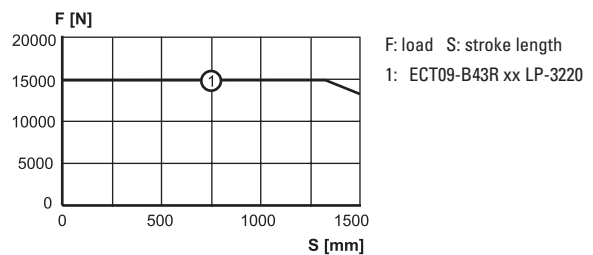



ECT90

Planetary Gear, Inline B53 AC Servo Motor

- » Ordering Key - see page 76
- » Mounting Options - see page 50
- » Adapter Options - see page 54
- » Glossary - see page 79



Standard Features and Benefits

- Robust and reliable
- Brushless AC servo motor
- Planetary gear
- Ball screw
- Hard-chromed steel extension tube
- IP65 as standard
- Stroke up to 1500 mm
- Load up to 20000 N
- Speed up to 270 mm/s

General Specifications

Parameter	ECT90
Profile size (w × h)	90 × 92 mm
Screw type	ball screw
Gear box	planetary gear
Motor type	brushless AC servo motor
Motor designation	AKM53K-ANCNR-00
Motor feedback	resolver
Motor connection	connector
Motor brake	no, optional
Lubrication	single point lubrication
Certificates	CE
Options	<ul style="list-style-type: none"> • motor brake (24 Vdc) • mounting options • adapter options

Performance Specifications

Parameter	ECT90
Stroke length (S), maximum [mm]	1500
Maximum dynamic load (Fx) ¹ [N]	ECT09-B53R10LP-3220 20000 ECT09-B53R05LP-3220 13000
Maximum load (Fy, Fz) ² [N]	500
Maximum load torque (My, Mz) [Nm]	150
Maximum speed [mm/s]	ECT09-B53R10LP-3220 130 ECT09-B53R05LP-3220 270
Operating temperature limits [°C]	-20 – 70
Screw diameters [mm]	32
Screw leads [mm]	20
Backlash [mm]	Screw diameter = 25 mm 0,11 Screw diameter = 32 mm 0,18
Repeatability [± mm]	0,05
Protection class, standard	IP65

¹ At a 100% duty cycle.

² Value at full retraction - decreases as the actuator extends.

ECT90

Planetary Gear, Inline B53 AC Servo Motor

Dimensions	Projection
METRIC	

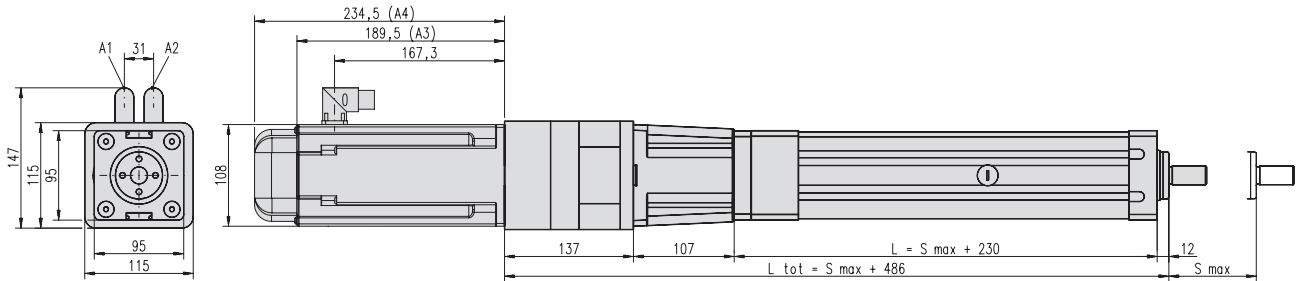

S max: maximum stroke (ordering stroke in mm)
 L: cover tube length
 L tot: retracted length

A1: power connector
 A2: resolver connector
 A3: without brake
 A4: with brake

Cover tube length (L)	[mm]	$L = S_{max} + 230$
Retracted length (L tot)	[mm]	$L_{tot} = S_{max} + 486$
Weight of unit	[kg]	$kg = 24,8 + 0,018 \times S_{max}$

Performance Diagrams

Speed vs. Load

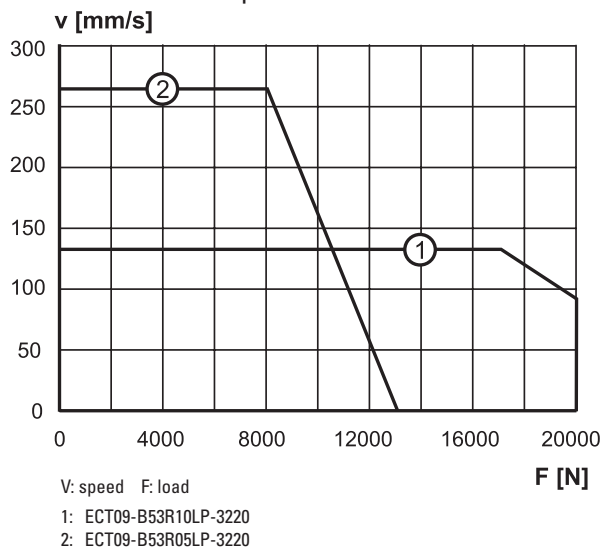

Critical Speed vs. Stroke

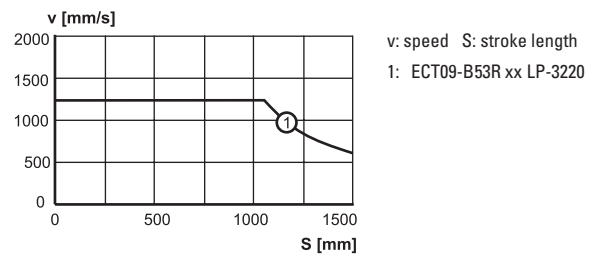

Column Load Limit vs. Stroke

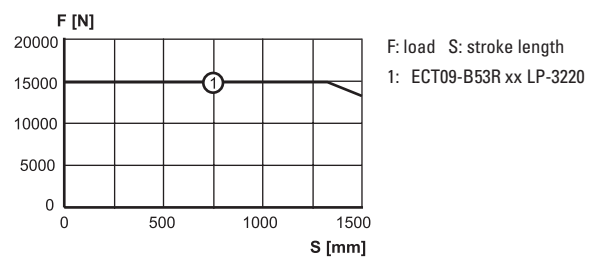



ECT130

Parallel IEC100 AC Motor

- » Ordering Key - see page 77
- » Mounting Options - see page 50
- » Adapter Options - see page 54
- » Glossary - see page 79

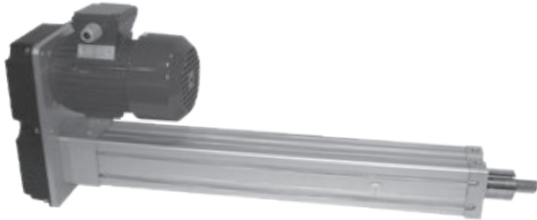

Standard Features and Benefits

- Robust and reliable
- Three-phase, asynchronous AC motor with brake
- Belt gear
- Ball screw
- Hard-chromed steel extension tube
- IP65 as standard
- Stroke up to 2000 mm
- Load up to 13300 N
- Speed up to 1900 mm/s

General Specifications

Parameter	ECT130
Profile size (w × h)	130 × 130 mm
Screw type	ball screw
Gear box	belt gear
Motor type	asynchronous AC motor
Motor voltage	3 × 400 Vac
Motor power	3,0 kW
Motor current, nominal	6,1 A
Motor feedback	no
Motor connection	terminal box
Motor brake	yes (230 Vac)
Lubrication	single point lubrication
Certificates	CE
Options	<ul style="list-style-type: none"> • mounting options • adapter options

Performance Specifications

Parameter	ECT130
Stroke length (S), maximum [mm]	2000
Maximum dynamic load (Fx) ¹ [N]	
ECT13-110B03PB-4010	13300
ECT13-110B02PB-4010	9400
ECT13-110B03PB-4020	6200
ECT13-110B02PB-4020	4200
ECT13-110B01PB-4020	1800
ECT13-110B01PB-4040	600
Maximum load (Fy, Fz) ² [N]	500
Maximum load torque (My, Mz) [Nm]	150
Maximum speed ³ [mm/s]	
ECT13-110B03PB-4010	175
ECT13-110B02PB-4010	210
ECT13-110B03PB-4020	300
ECT13-110B02PB-4020	420
ECT13-110B01PB-4020	950
ECT13-110B01PB-4040	1900
Operating temperature limits [°C]	-20 – 70
Screw diameters [mm]	40
Screw leads [mm]	10, 20, 40
Backlash [mm]	0,21
Repeatability [± mm]	0,05
Protection class, standard	IP65

¹ At a 100% duty cycle.

² Value at full retraction - decreases as the actuator extends.

³ The maximum speed is based on a max. input frequency to the motor of 50 Hz. Frequency inverters can provide higher frequencies thus higher speeds but that may damage the actuator.

ECT130

Parallel IEC100 AC Motor

Dimensions	Projection
METRIC	

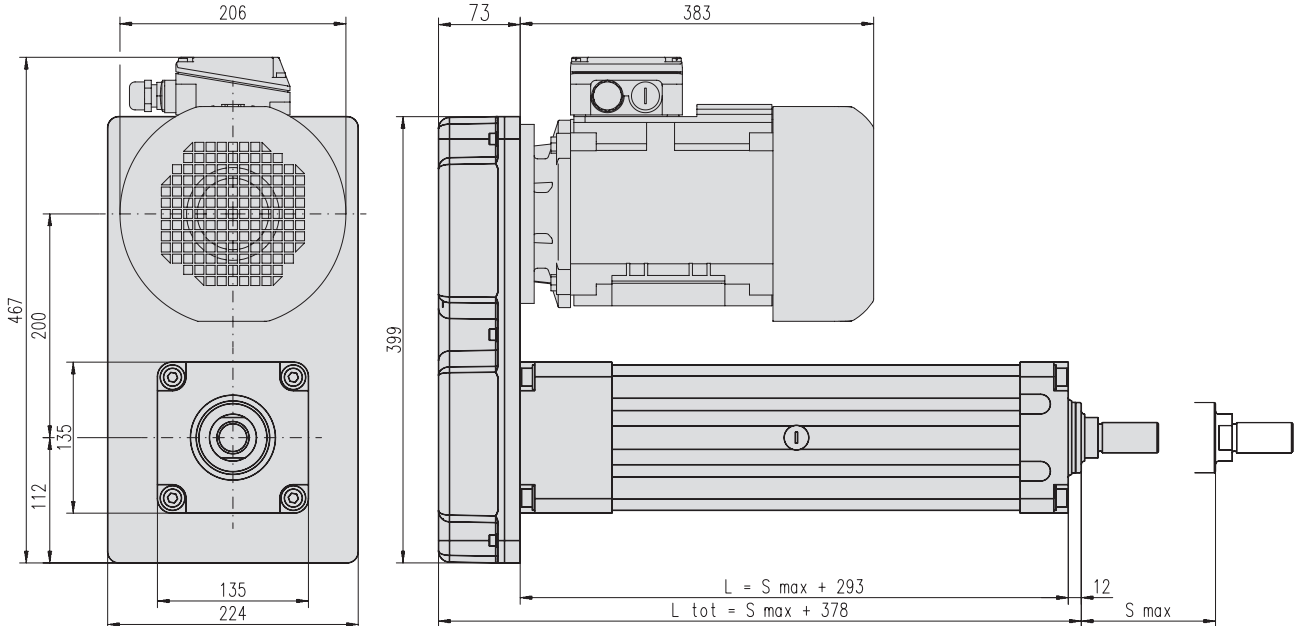

S max: maximum stroke (ordering stroke in mm)
 L: cover tube length
 L tot: retracted length

Cover tube length (L)	[mm]	$L = S_{max} + 293$
Retracted length (L tot)	[mm]	$L_{tot} = S_{max} + 378$
Weight of unit	[kg]	$kg = 63,5 + 0,03 \times S_{max}$

Performance Diagrams

Speed vs. Load

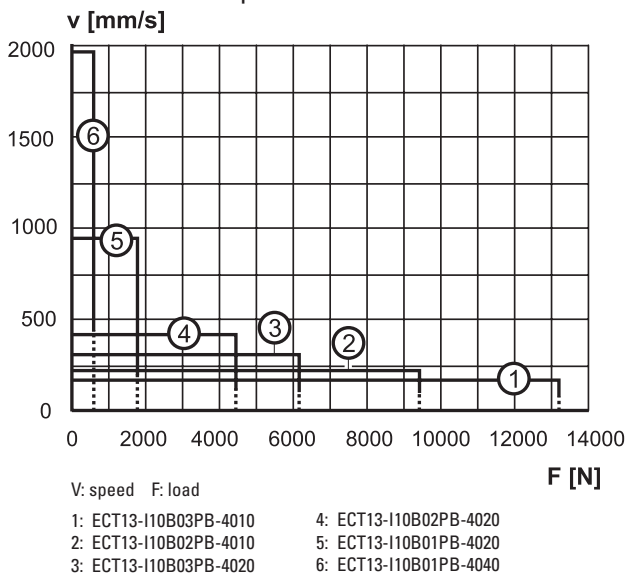

..... = Overheating of the motor may occur if running at this speed continuously!

Critical Speed vs. Stroke

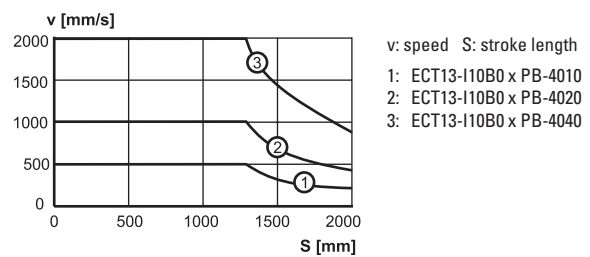

Column Load Limit vs. Stroke

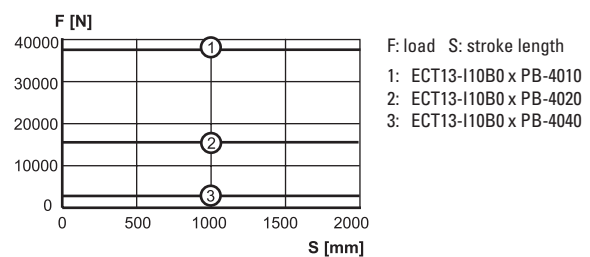



ECT130

Parallel B53 AC Servo Motor

- » Ordering Key - see page 77
- » Mounting Options - see page 50
- » Adapter Options - see page 54
- » Glossary - see page 79



Standard Features and Benefits

- Robust and reliable
- Brushless AC servo motor
- Belt gear
- Ball screw
- Hard-chromed steel extension tube
- IP65 as standard
- Stroke up to 2000 mm
- Load up to 15000 N
- Speed up to 440 mm/s

General Specifications

Parameter	ECT130
Profile size (w × h)	130 × 130 mm
Screw type	ball screw
Gear box	belt gear
Motor type	brushless AC servo motor
Motor designation	AKM53K-CNCNR-00
Motor feedback	resolver
Motor connection	connector
Motor brake	no, optional
Lubrication	single point lubrication
Certificates	CE
Options	<ul style="list-style-type: none"> • motor brake (24 Vdc) • mounting options • adapter options

Performance Specifications

Parameter	ECT130
Stroke length (S), maximum [mm]	2000
Maximum dynamic load (Fx) ¹ [N]	ECT13-B53R03PB-4010 15000 ECT13-B53R02PB-4010 10500 ECT13-B53R03PB-4020 7000 ECT13-B53R02PB-4020 5000
Maximum load (Fy, Fz) ² [N]	500
Maximum load torque (My, Mz) [Nm]	150
Maximum speed [mm/s]	ECT13-B53R03PB-4010 160 ECT13-B53R02PB-4010 220 ECT13-B53R03PB-4020 320 ECT13-B53R02PB-4020 440
Operating temperature limits [°C]	-20 – 70
Screw diameters [mm]	40
Screw leads [mm]	10, 20
Backlash [mm]	0,21
Repeatability [± mm]	0,05
Protection class, standard	IP65

¹At a 100% duty cycle.

²Value at full retraction - decreases as the actuator extends.

ECT130

Parallel B53 AC Servo Motor

Dimensions	Projection
METRIC	

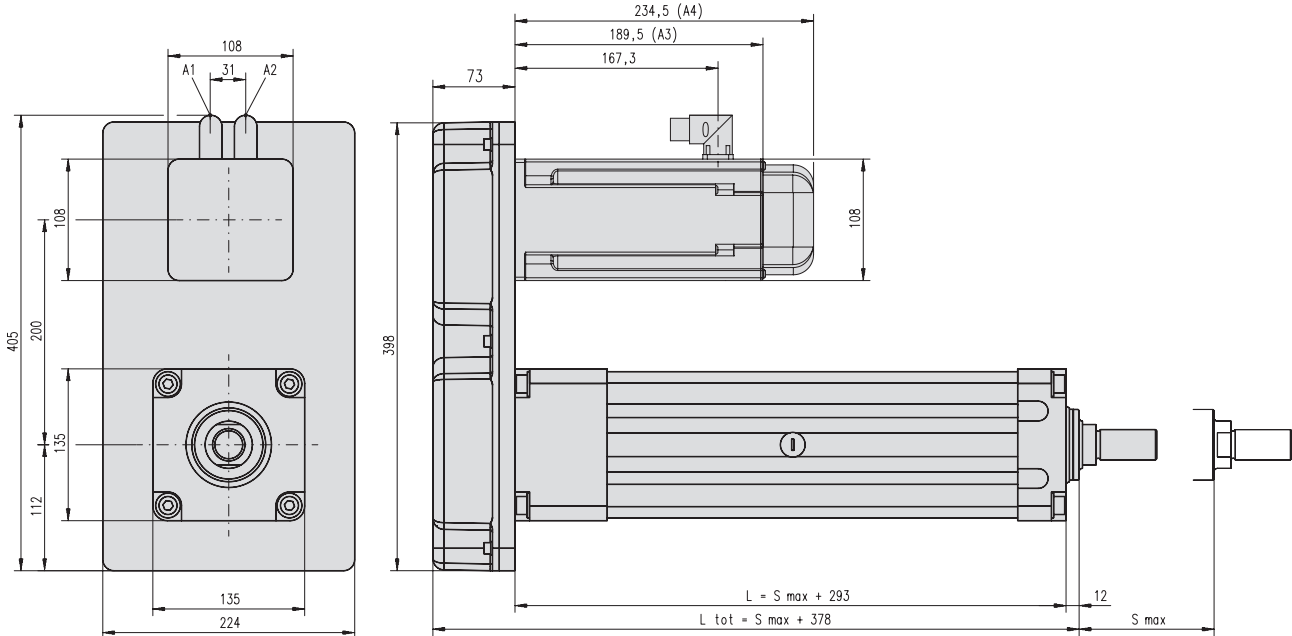

S max: maximum stroke (ordering stroke in mm)
 L: cover tube length
 L tot: retracted length

A1: power connector
 A2: resolver connector
 A3: without brake
 A4: with brake

Cover tube length (L)	[mm]	$L = S \text{ max} + 293$
Retracted length (L tot)	[mm]	$L \text{ tot} = S \text{ max} + 378$
Weight of unit	[kg]	$\text{kg} = 39,9 + 0,03 \times S \text{ max}$

Performance Diagrams

Speed vs. Load

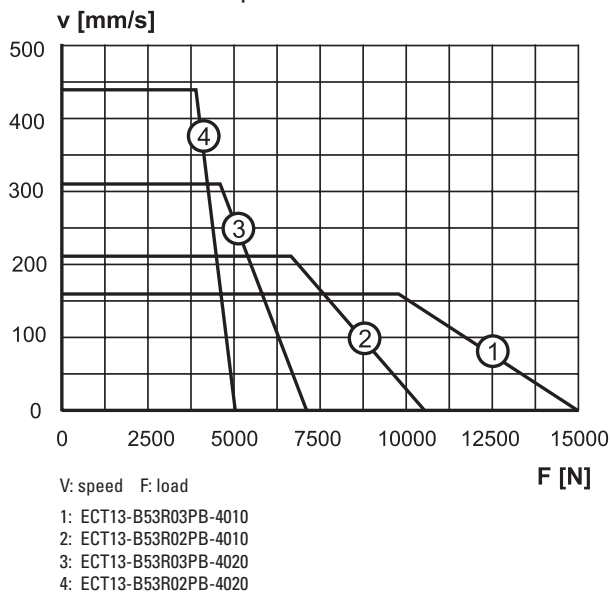

Critical Speed vs. Stroke

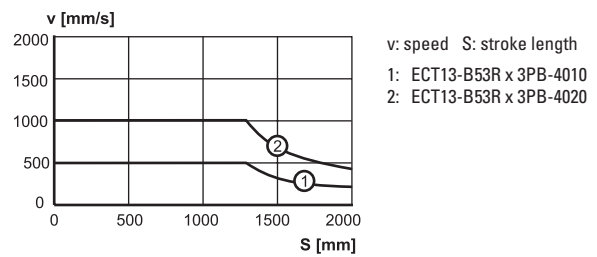

Column Load Limit vs. Stroke

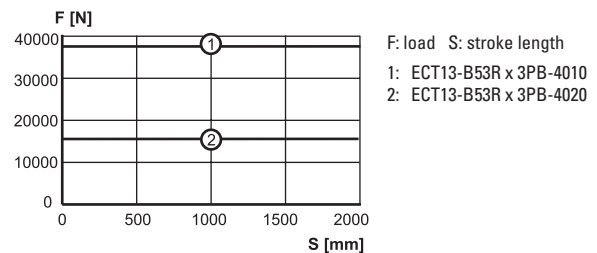



ECT130

Parallel B63 AC Servo Motor

- » Ordering Key - see page 77
- » Mounting Options - see page 50
- » Adapter Options - see page 54
- » Glossary - see page 79



Standard Features and Benefits

- Robust and reliable
- Brushless AC servo motor
- Belt gear
- Ball screw
- Hard-chromed steel extension tube
- IP65 as standard
- Stroke up to 2000 mm
- Load up to 21500 N
- Speed up to 440 mm/s

General Specifications

Parameter	ECT130
Profile size (w × h)	130 × 130 mm
Screw type	ball screw
Gear box	belt gear
Motor type	brushless AC servo motor
Motor designation	AKM63K-ANCNR-00
Motor feedback	resolver
Motor connection	connector
Motor brake	no, optional
Lubrication	single point lubrication
Certificates	CE
Options	<ul style="list-style-type: none"> • motor brake (24 Vdc) • mounting options • adapter options

Performance Specifications

Parameter	ECT130
Stroke length (S), maximum [mm]	2000
Maximum dynamic load (Fx) ¹ [N]	ECT13-B63R03PB-4010 21500 ECT13-B63R02PB-4010 15500 ECT13-B63R03PB-4020 10500 ECT13-B63R02PB-4020 7500
Maximum load (Fy, Fz) ² [N]	500
Maximum load torque (My, Mz) [Nm]	150
Maximum speed [mm/s]	ECT13-B63R03PB-4010 160 ECT13-B63R02PB-4010 220 ECT13-B63R03PB-4020 320 ECT13-B63R02PB-4020 440
Operating temperature limits [°C]	-20 – 70
Screw diameters [mm]	40
Screw leads [mm]	10, 20
Backlash [mm]	0,21
Repeatability [± mm]	0,05
Protection class, standard	IP65

¹At a 100% duty cycle.

²Value at full retraction - decreases as the actuator extends.

ECT130

Parallel B63 AC Servo Motor

Dimensions	Projection
METRIC	

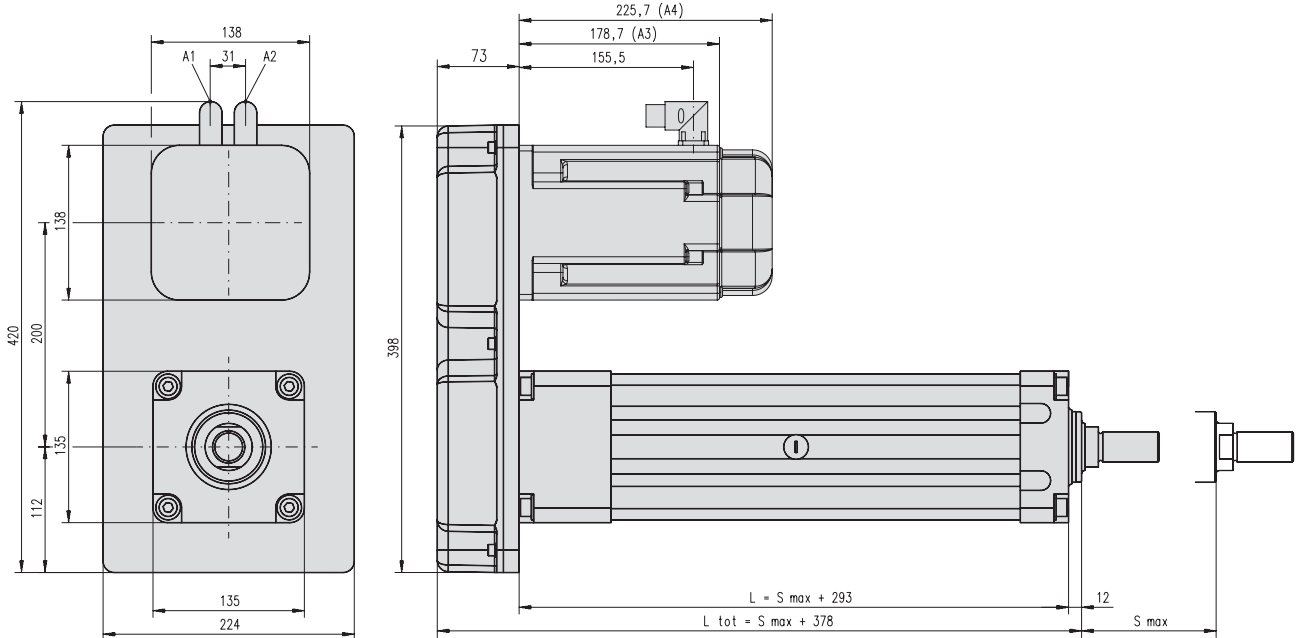

S max: maximum stroke (ordering stroke in mm)
 L: cover tube length
 L tot: retracted length

A1: power connector
 A2: resolver connector
 A3: without brake
 A4: with brake

Cover tube length (L)	[mm]	$L = S_{max} + 293$
Retracted length (L tot)	[mm]	$L_{tot} = S_{max} + 378$
Weight of unit	[kg]	$kg = 43,6 + 0,03 \times S_{max}$

Performance Diagrams

Speed vs. Load

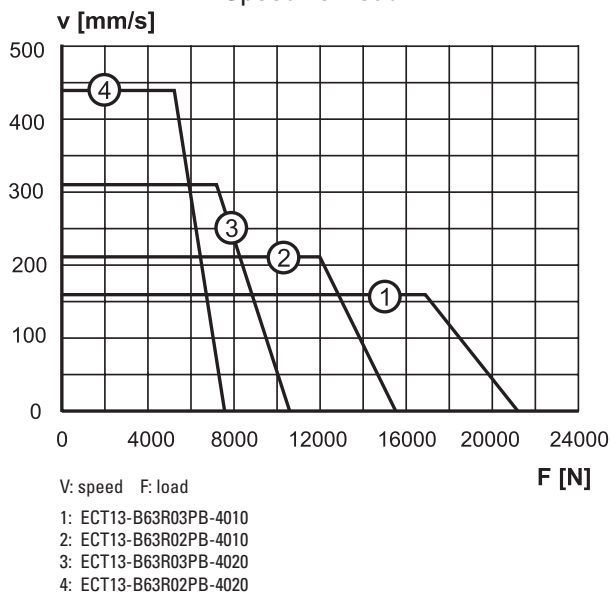

Critical Speed vs. Stroke

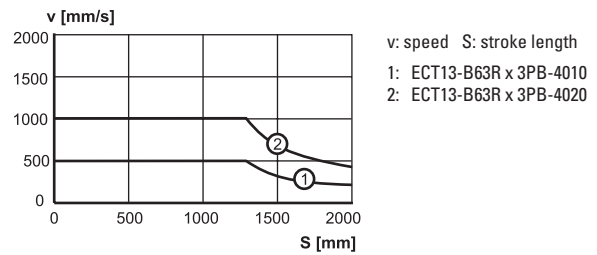

Column Load Limit vs. Stroke

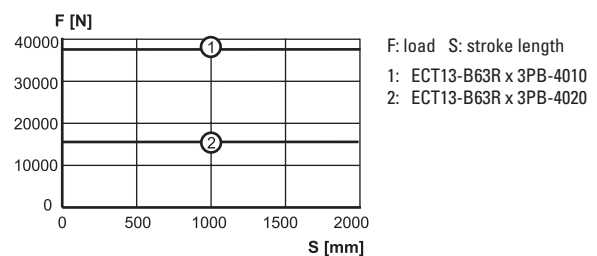



ECT130

Direct Drive, Inline B53 AC Servo Motor

- » Ordering Key - see page 78
- » Mounting Options - see page 50
- » Adapter Options - see page 54
- » Glossary - see page 79



Standard Features and Benefits

- Robust and reliable
- Brushless AC servo motor
- Direct drive
- Ball screw
- Hard-chromed steel extension tube
- IP65 as standard
- Stroke up to 2000 mm
- Load up to 4900 N
- Speed up to 2000 mm/s

General Specifications

Parameter	ECT130
Profile size (w × h)	130 × 130 mm
Screw type	ball screw
Gear box	no, direct drive
Motor type	brushless AC servo motor
Motor designation	AKM53K-ANCNR-00
Motor feedback	resolver
Motor connection	connector
Motor brake	no, optional
Lubrication	single point lubrication
Certificates	CE
Options	<ul style="list-style-type: none"> • motor brake (24 Vdc) • mounting options • adapter options

Performance Specifications

Parameter	ECT130
Stroke length (S), maximum [mm]	2000
Maximum dynamic load (Fx) ¹ [N]	ECT13-B53R01LD-4010 4900 ECT13-B53R01LD-4020 2250 ECT13-B53R01LD-4040 700
Maximum load (Fy, Fz) ² [N]	500
Maximum load torque (My, Mz) [Nm]	150
Maximum speed [mm/s]	ECT13-B53R01LD-4010 400 ECT13-B53R01LD-4020 1000 ECT13-B53R01LD-4040 2000
Operating temperature limits [°C]	-20 – 70
Screw diameters [mm]	40
Screw leads [mm]	10, 20, 40
Backlash [mm]	0,21
Repeatability [± mm]	0,05
Protection class, standard	IP65

¹ At a 100% duty cycle.

² Value at full retraction - decreases as the actuator extends.

ECT130

Direct Drive, Inline B53 AC Servo Motor

Dimensions	Projection
METRIC	

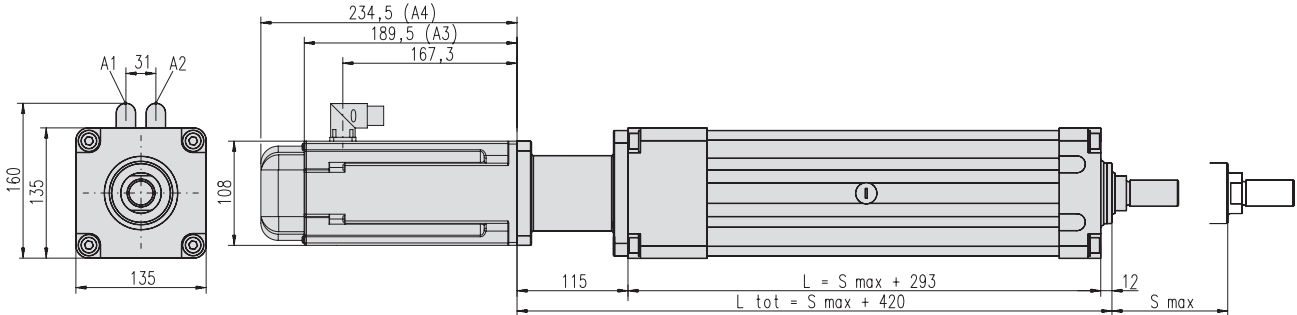

S max: maximum stroke (ordering stroke in mm)
 L: cover tube length
 L tot: retracted length

A1: power connector
 A2: resolver connector
 A3: without brake

A4: with brake

Cover tube length (L)	[mm]	$L = S_{max} + 293$
Retracted length (L tot)	[mm]	$L_{tot} = S_{max} + 420$
Weight of unit	[kg]	$kg = 28,7 + 0,03 \times S_{max}$

Performance Diagrams

Speed vs. Load

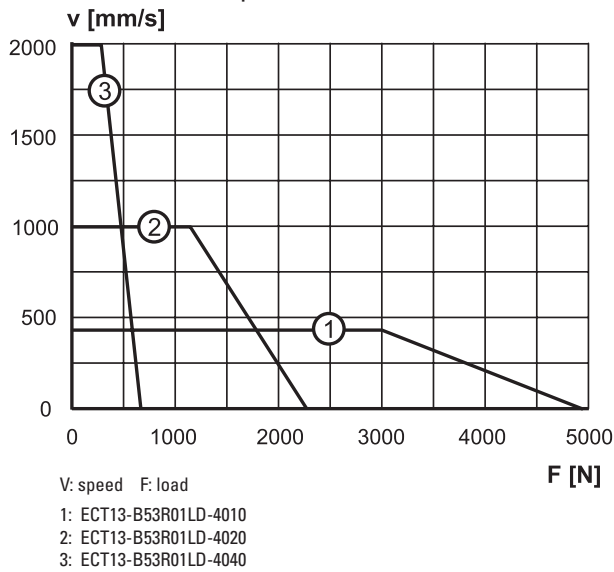

Critical Speed vs. Stroke

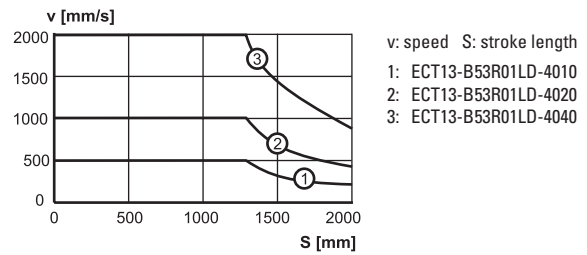

Column Load Limit vs. Stroke

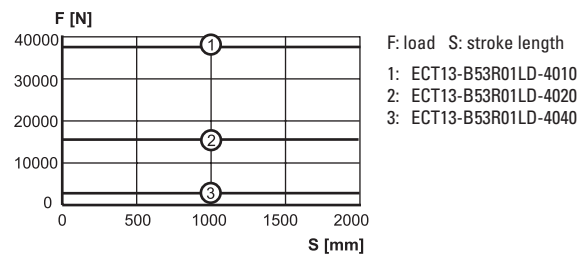



ECT130

Direct Drive, Inline B63 AC Servo Motor

- » Ordering Key - see page 78
- » Mounting Options - see page 50
- » Adapter Options - see page 54
- » Glossary - see page 79



Standard Features and Benefits

- Robust and reliable
- Brushless AC servo motor
- Direct drive
- Ball screw
- Hard-chromed steel extension tube
- IP65 as standard
- Stroke up to 2000 mm
- Load up to 7400 N
- Speed up to 2000 mm/s

General Specifications

Parameter	ECT130
Profile size (w × h)	130 × 130 mm
Screw type	ball screw
Gear box	no, direct drive
Motor type	brushless AC servo motor
Motor designation	AKM63K-ANCNR-00
Motor feedback	resolver
Motor connection	connector
Motor brake	no, optional
Lubrication	single point lubrication
Certificates	CE
Options	<ul style="list-style-type: none"> • motor brake (24 Vdc) • mounting options • adapter options

Performance Specifications

Parameter	ECT130
Stroke length (S), maximum [mm]	2000
Maximum dynamic load (Fx) ¹ [N]	ECT13-B63R01LD-4010 7400 ECT13-B63R01LD-4020 3400 ECT13-B63R01LD-4040 1400
Maximum load (Fy, Fz) ² [N]	500
Maximum load torque (My, Mz) [Nm]	150
Maximum speed [mm/s]	ECT13-B63R01LD-4010 400 ECT13-B63R01LD-4020 1000 ECT13-B63R01LD-4040 2000
Operating temperature limits [°C]	-20 – 70
Screw diameters [mm]	40
Screw leads [mm]	10, 20, 40
Backlash [mm]	0,21
Repeatability [± mm]	0,05
Protection class, standard	IP65

¹ At a 100% duty cycle.

² Value at full retraction - decreases as the actuator extends.

ECT130

Direct Drive, Inline B63 AC Servo Motor

Dimensions	Projection
METRIC	

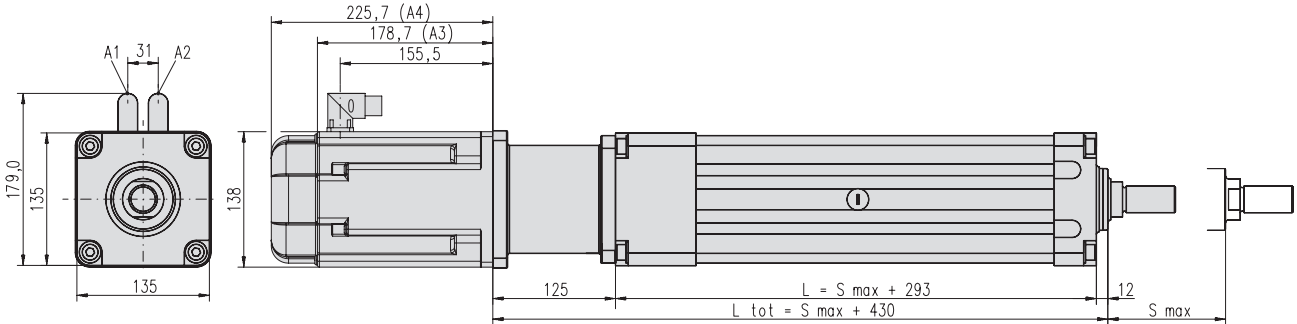

S max: maximum stroke (ordering stroke in mm)
 L: cover tube length
 L tot: retracted length

A1: power connector
 A2: resolver connector
 A3: without brake

A4: with brake

Cover tube length (L)	[mm]	$L = S \text{ max} + 293$
Retracted length (L tot)	[mm]	$L \text{ tot} = S \text{ max} + 430$
Weight of unit	[kg]	$\text{kg} = 32,8 + 0,03 \times S \text{ max}$

Performance Diagrams

Speed vs. Load

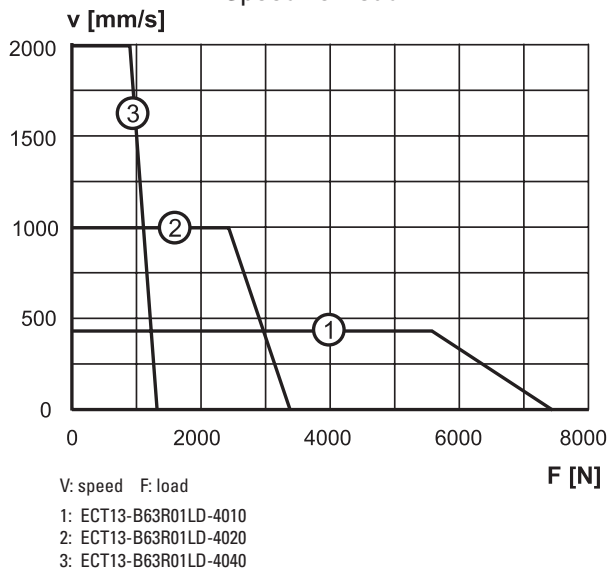

Critical Speed vs. Stroke

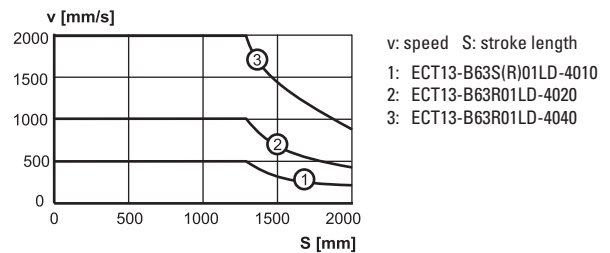

Column Load Limit vs. Stroke

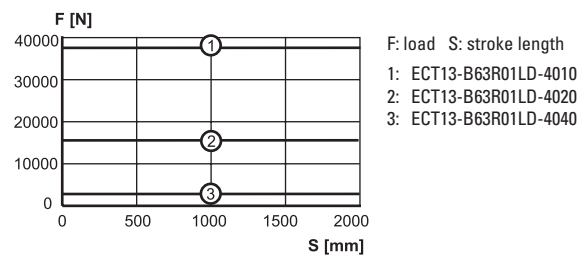



ECT130

Planetary Gear, Inline B53 AC Servo Motor

- » Ordering Key - see page 78
- » Mounting Options - see page 50
- » Adapter Options - see page 54
- » Glossary - see page 79



Standard Features and Benefits

- Robust and reliable
- Brushless AC servo motor
- Planetary gear
- Ball screw
- Hard-chromed steel extension tube
- IP65 as standard
- Stroke up to 2000 mm
- Load up to 38000 N
- Speed up to 200 mm/s

General Specifications

Parameter	ECT130
Profile size (w × h)	130 × 130 mm
Screw type	ball screw
Gear box	planetary gear
Motor type	brushless AC servo motor
Motor designation	AKM53K-ANCNR-00
Motor feedback	resolver
Motor connection	connector
Motor brake	no, optional
Lubrication	single point lubrication
Certificates	CE
Options	<ul style="list-style-type: none"> • motor brake (24 Vdc) • mounting options • adapter options

Performance Specifications

Parameter	ECT130
Stroke length (S), maximum [mm]	2000
Maximum dynamic load (Fx) ¹ [N]	ECT13-B53R10LP-4010 38000 ECT13-B53R05LP-4010 22500 ECT13-B53R05LP-4020 11000
Maximum load (Fy, Fz) ² [N]	500
Maximum load torque (My, Mz) [Nm]	150
Maximum speed [mm/s]	ECT13-B53R10LP-4010 50 ECT13-B53R05LP-4010 100 ECT13-B53R05LP-4020 200
Operating temperature limits [°C]	-20 – 70
Screw diameters [mm]	40
Screw leads [mm]	10, 20
Backlash [mm]	0,21
Repeatability [± mm]	0,05
Protection class, standard	IP65

¹ At a 100% duty cycle.

² Value at full retraction - decreases as the actuator extends.

ECT130

Planetary Gear, Inline B53 AC Servo Motor

Dimensions	Projection
METRIC	

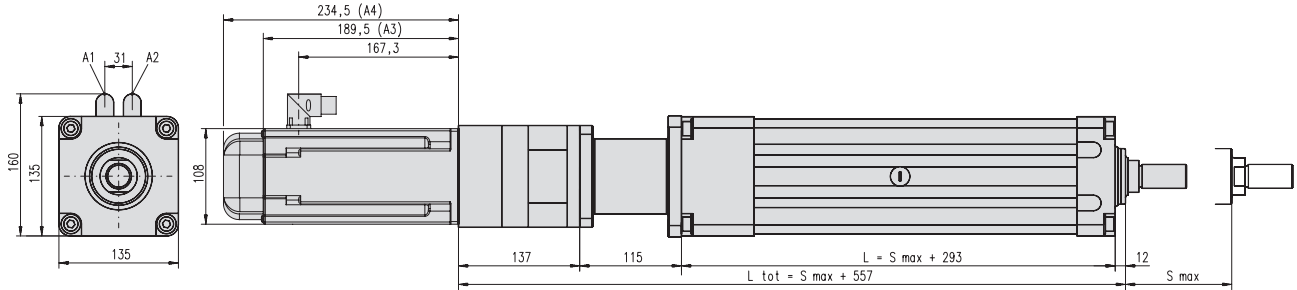

S max: maximum stroke (ordering stroke in mm)
 L: cover tube length
 L tot: retracted length

A1: power connector
 A2: resolver connector
 A3: without brake

A4: with brake

Cover tube length (L)	[mm]	$L = S_{max} + 293$
Retracted length (L tot)	[mm]	$L_{tot} = S_{max} + 557$
Weight of unit	[kg]	$kg = 33,9 + 0,03 \times S_{max}$

Performance Diagrams

Speed vs. Load

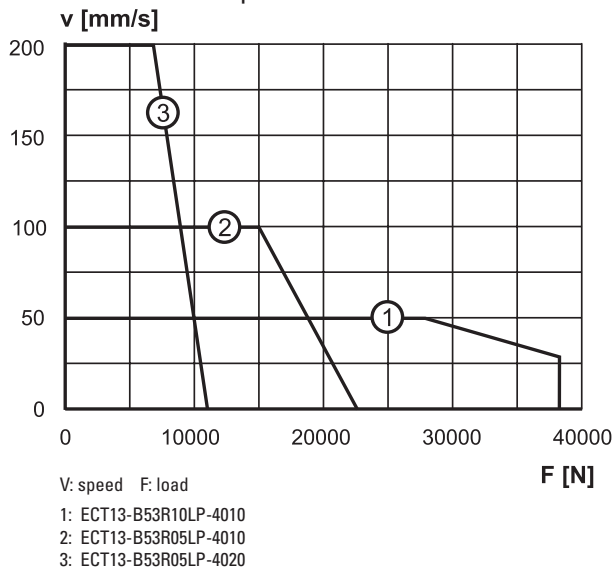

Critical Speed vs. Stroke

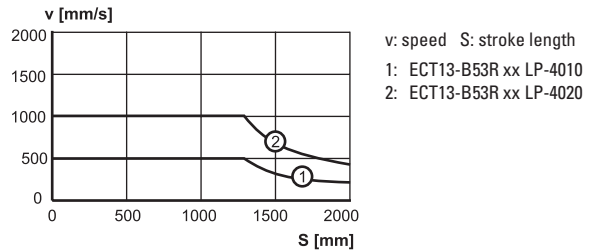

Column Load Limit vs. Stroke

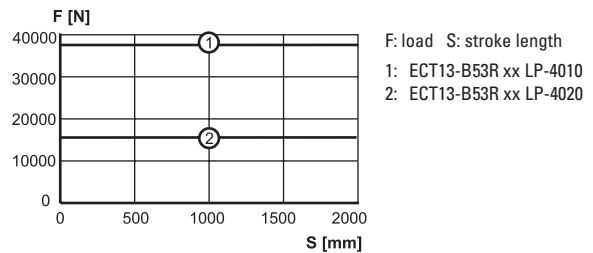



ECT130

Planetary Gear, Inline B63 AC Servo Motor

- » Ordering Key - see page 78
- » Mounting Options - see page 50
- » Adapter Options - see page 54
- » Glossary - see page 79



Standard Features and Benefits

- Robust and reliable
- Brushless AC servo motor
- Planetary gear
- Ball screw
- Hard-chromed steel extension tube
- IP65 as standard
- Stroke up to 2000 mm
- Load up to 33000 N
- Speed up to 200 mm/s

General Specifications

Parameter	ECT130
Profile size (w × h)	130 × 130 mm
Screw type	ball screw
Gear box	planetary gear
Motor type	brushless AC servo motor
Motor designation	AKM63K-ANCNR-00
Motor feedback	resolver
Motor connection	connector
Motor brake	no, optional
Lubrication	single point lubrication
Certificates	CE
Options	<ul style="list-style-type: none"> • motor brake (24 Vdc) • mounting options • adapter options

Performance Specifications

Parameter	ECT130
Stroke length (S), maximum [mm]	2000
Maximum dynamic load (Fx) ¹ [N]	33000 16000
Maximum load (Fy, Fz) ² [N]	500
Maximum load torque (My, Mz) [Nm]	150
Maximum speed [mm/s]	100 200
Operating temperature limits [°C]	-20 – 70
Screw diameters [mm]	40
Screw leads [mm]	10, 20
Backlash [mm]	0,21
Repeatability [± mm]	0,05
Protection class, standard	IP65

¹At a 100% duty cycle.

²Value at full retraction - decreases as the actuator extends.

ECT130

Planetary Gear, Inline B63 AC Servo Motor

Dimensions	Projection
METRIC	

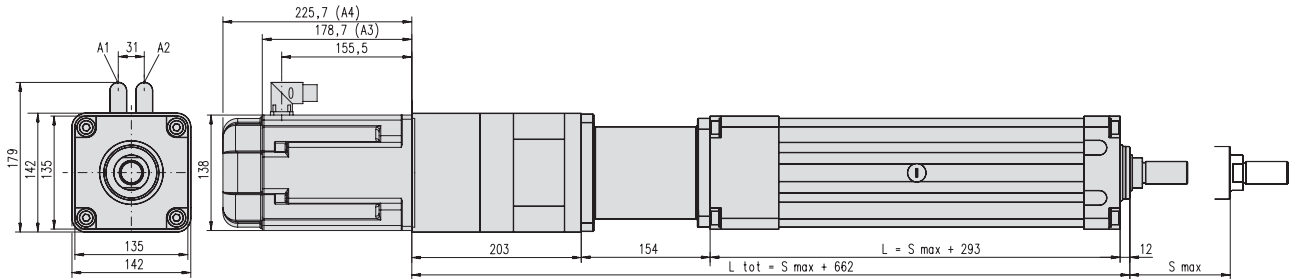

S max: maximum stroke (ordering stroke in mm)
 L: cover tube length
 L tot: retracted length

A1: power connector
 A2: resolver connector
 A3: without brake

A4: with brake

Cover tube length (L)	[mm]	$L = S_{max} + 293$
Retracted length (L tot)	[mm]	$L_{tot} = S_{max} + 662$
Weight of unit	[kg]	$kg = 46,8 + 0,03 \times S_{max}$

Performance Diagrams

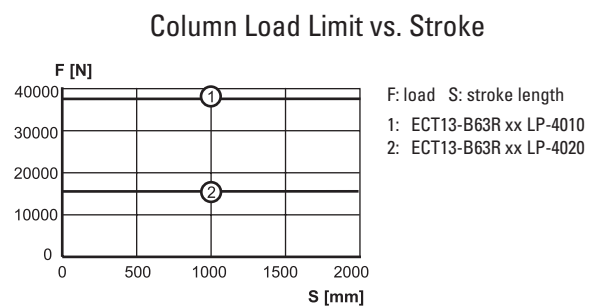
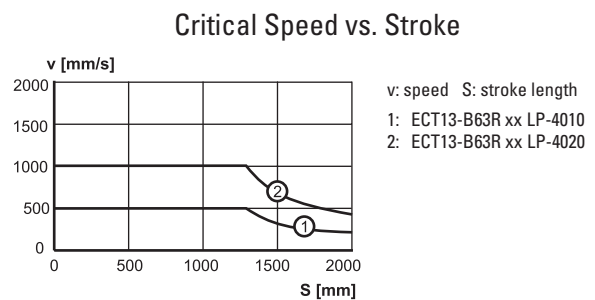
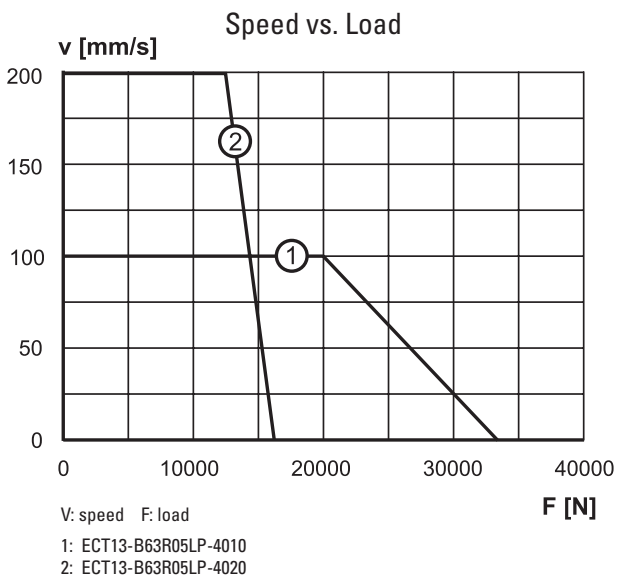



Options and Accessories

Mounting

Mounting Holes - Standard Feature on All Units (ordering code X)

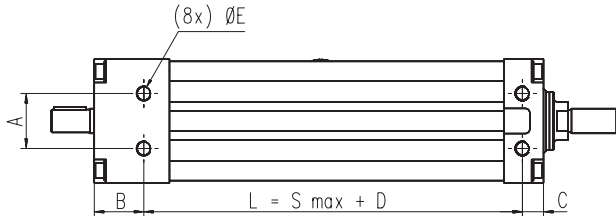

All T and ECT models have mounting holes as standard. However, if mounting feet type F are used, these holes will be occupied by the attachment screws for the feet. Note: The distances "B" and "D" can be different depending on the diameter or lead of the unit screw.

	A	B	C	D	E
T60	46	34,5	14	124,5 ¹ / 146,5 ²	M8 × 10
T90 / ECT90	45	39 ¹ / 48 ²	15	141 ³ / 167 ⁴	M12 × 18
T130 / ECT130	60	54	23	216	M16 × 28

¹ T06-B2505, T06-B2525 ² T06-B2510, T06-B2550 ³ T09-B25, ECT09-B xxxxxxxx25 ⁴ T09-B32, ECT09-B xxxxxxxx32

T-slots and T-slot Bolts - Standard Feature on All Units

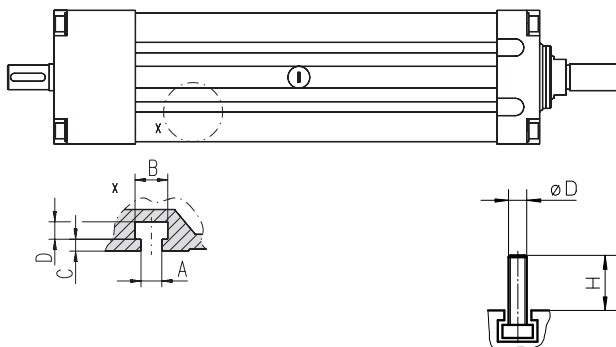

The T60, T90, T130, ECT90 and ECT130 models all have T-slots running along the entire profile. T60 has two T-slots (one on each side), while the other models have four (two on each side). Suitable T-slot bolts can be ordered using the part numbers in the table below.

	A	B	C	D
T60	21,8	26,4	2,55	3,4
T90 / ECT90	6,4	10,5	3,5	4,5
T130 / ECT130	10,5	16,5	6,0	9,0

	ø D	H	p/n
T60	M5	14	D312 221
T90 / ECT90	M6	18	D310 314
T90 / ECT90	M6	26	D310 311
T130 / ECT130	M10	28	D800 089

Options and Accessories

Mounting

Fixed Mounting Feet (ordering code F)

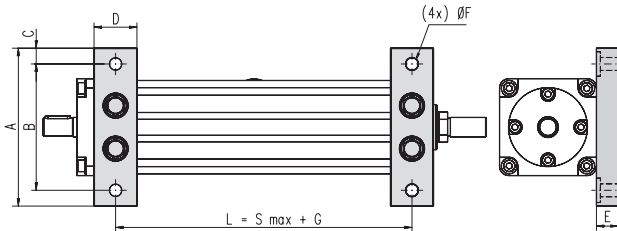

The fixed mounting feet are available for units type T90, ECT90, T130 and ECT 130 only. This option can be mounted on the unit from the factory if stated in the ordering key at order, or can be ordered separately using the part number. When ordered separately, all necessary screws to attach the feet are included. Note: The distance "G" can be different depending on the screw diameter of the unit.

	A	B	C	D	E	F	G	p/n
T90 / ECT90	155	125	15	40	20	13	141 ¹ / 162 ²	D606 225
T130 / ECT130	220	176	22	60	30	17	216 /	D606 157

¹ T09-B25, ECT09-B xxxxxxxx 25 ² T09-B32, ECT09-B xxxxxxxx 32

Movable Mounting Feet Clamps (ordering code F)

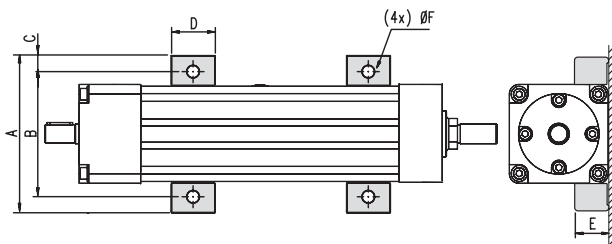

The movable mounting feet clamp accessory is only available for T60 units. This option can be mounted on the unit from the factory if stated in the ordering key at order, in which case you get four clamps, or they can be ordered as separate pieces using the part number. Normally you would need four clamps per unit. The clamps fit into the T-slot running along each side of the unit.

	A	B	C	D	E	F	p/n
T60	109	87	9,7	25	20,8	6,5	D313 618



Options and Accessories

Mounting

Front Mounting Plates type (ordering code G)

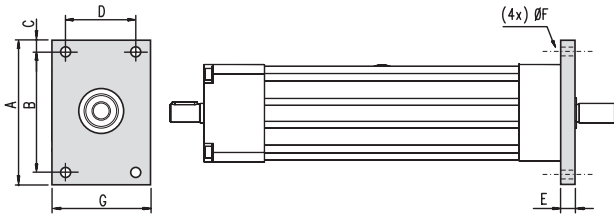

The front mounting plates must be mounted from the factory as a part of the assembly of the unit and cannot be mounted afterwards by the customer.

	A	B	C	D	E	F	G	p/n
T60	120	100	10	56	14	7	75	D606 359
T90 / ECT90	150	126	12	72	16	9	95	D606 360
T130 / ECT130	205	180	12,5	110	20	11	140	D606 361

Options and Accessories

Mounting

Trunnion type (ordering code T)

Trunnion kit for T60

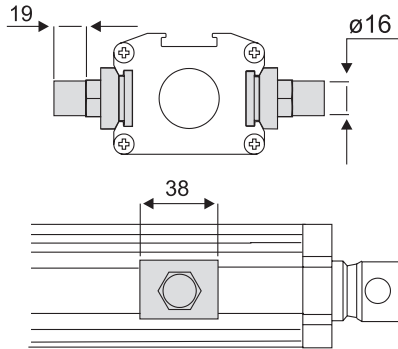

The trunnion option can be mounted on the unit from the factory if this is stated in the ordering key at order, or be ordered separately using the part number. When ordered separately, all necessary screws to attach the trunnions to the unit are included. The position along the profile can be adjusted freely by the customer. A trunnion bracket kit is available for T60, which is ordered separately.

Trunnion bracket kit for T60

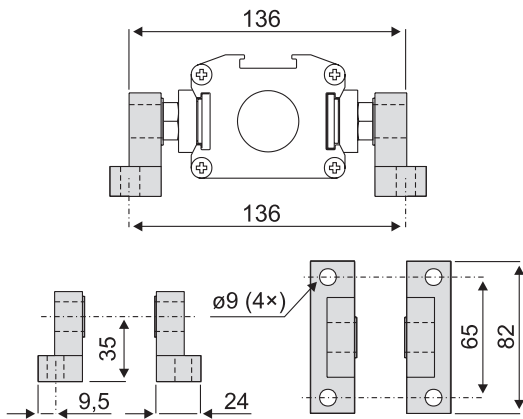

	p/n
T60 trunnion kit	D603 022
T60 trunnion bracket kit	D603 030
T90 / ECT90 trunnion kit	D606 030
T130 / ECT130 trunnion kit	D606 155

Trunnion kit for T90, T130, ECT90, ECT130

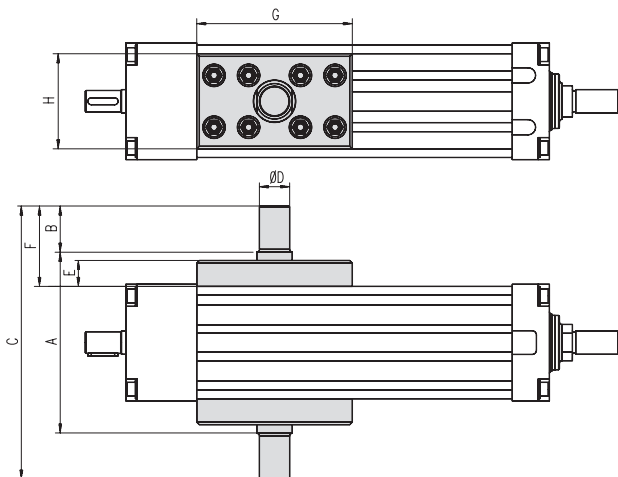

	A	B	C	D	E	F	G	H
T90 / ECT90	150	45	240	20f8	25	75	130	80
T130 / ECT130	210	53	316	35f8	30	93	180	110

Options and Accessories

Adapters

Inside Thread (ordering code P and R)

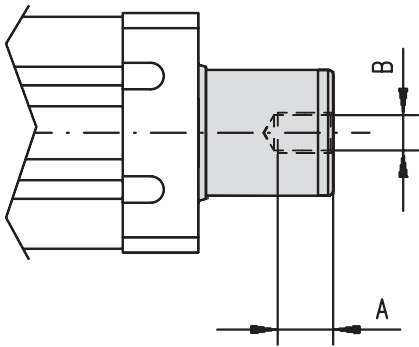

The inside thread option comes mounted from factory if this is stated in the ordering key at order. Possible types for the different unit sizes depend on the ball screw diameter of the unit, see "Ball screw diameter" in the table.

	Ball screw diameter	Type	A	B
T60	25 mm	P	22	M16 × 2
T90 / ECT90	25 mm	P	22	M16 × 2
T90 / ECT90	25, 32 mm	R	24	M20 × 1,5

Inside Thread (ordering code T, V and X)

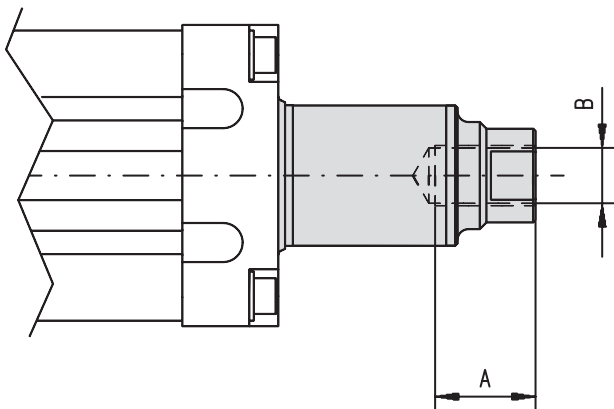

The inside thread option comes mounted from factory if this is stated in the ordering key at order. Possible types for the different unit sizes depend on the ball screw diameter of the unit, see "Ball screw diameter" in the table.

	Ball screw diameter	Type	A	B
T130 / ECT130	40 mm	T	45	M27 × 2
T130 / ECT130	40, 50 mm	V	45	M33 × 2
T130 / ECT130	40 mm	X	45	M30 × 2

Options and Accessories

Adapters

Outside Thread (ordering code N and Q)

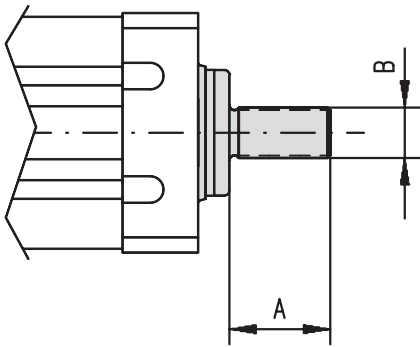

The outside thread option comes mounted from factory if this is stated in the ordering key at order. Possible types for the different unit sizes depend on the ball screw diameter of the unit, see "Ball screw diameter" in the table.

	Ball screw diameter	Type	A	B
T60 / T90 / ECT90	25 mm	N	32	M16 × 1,5
T90 / ECT90	25, 32 mm	Q	40	M20 × 1,5

Outside Thread (ordering code S and U)

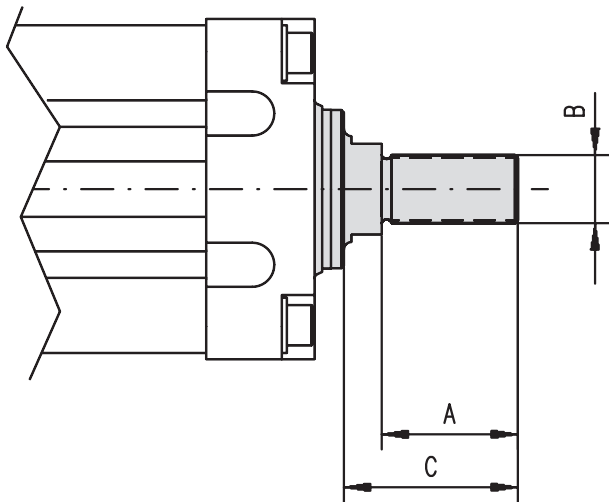

The outside thread option comes mounted from factory if this is stated in the ordering key at order. Possible types for the different unit sizes depend on the ball screw diameter of the unit, see "Ball screw diameter" in the table.

	Ball screw diameter	Type	A	B	C
T130 / ECT130	40 mm	S	54	M27 × 2	66
T130 / ECT130	40, 50 mm	U	45	M33 × 2	57



Options and Accessories

Adapters

Spherical Joint (ordering code J and K)

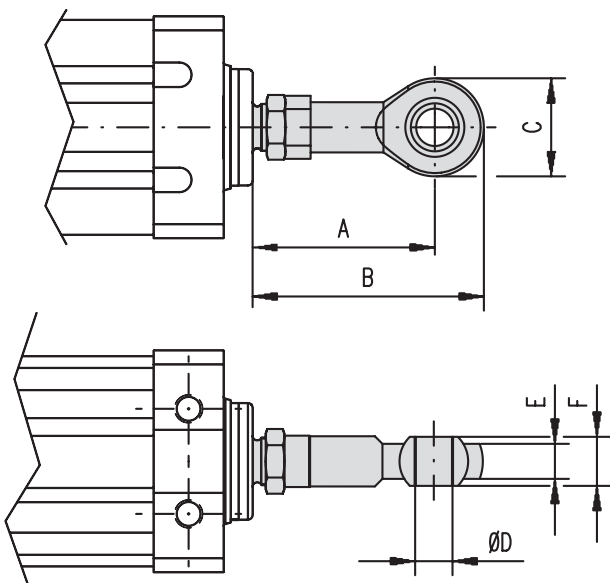

The spherical joint option can be mounted on the unit from the factory if this is stated in the ordering key at order, or can be ordered separately using the part numbers. When ordered separately, all necessary components to attach the spherical joints to the unit are included. Note: When ordering a spherical joint separately, make sure that the extension tube end has an outside thread adapter to be able to mount it.

	Type	A	B	C	D	E	F	p/n
T60 / T90 / ECT90 ¹	J	76	97	42	16	15	21	D606 193 + D290 286
T90 / ECT90 ²	K	90	115	50	20	18	25	D606 192 + D290 281

¹ Only fits T60, T90 and ECT90 units with diameter 25 mm screw (T06xxxxxx25, T09xxxxxx25 and ECT09-xxxxxx25)

² Only fits T90 and ECT90 units with diameter 32 mm screw (T09xxxxxx32 and ECT09-xxxxxx32)

Options and Accessories

Adapters

Spherical Joint (ordering code L and M)

Type L

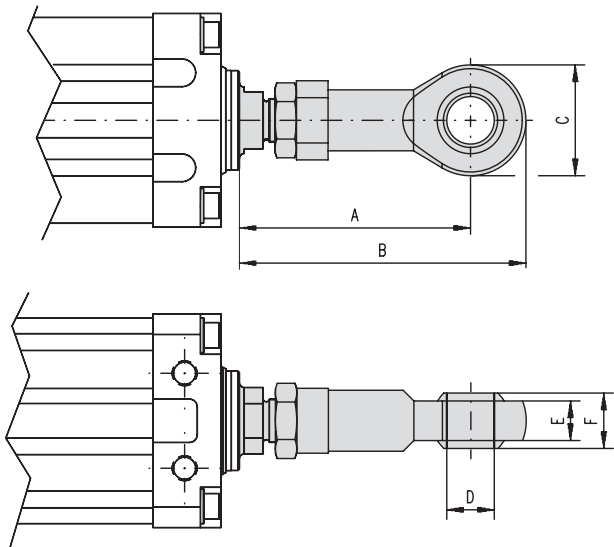

The spherical joint option can be mounted on the unit from the factory if this is stated in the ordering key at order, or can be ordered separately using the part number(s). When ordered separately, all necessary components to attach the spherical joints to the unit are included. Type M joints include a grease nipple. Note: When ordering a spherical joint separately, make sure that the extension tube end has an outside thread adapter to be able to mount it.

Type M

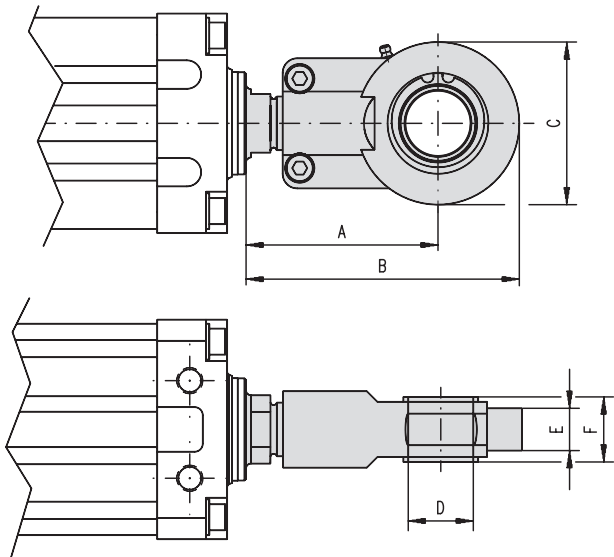

	Type	A	B	C	D	E	F	p/n
T130 / ECT130	L ¹	137	172	70	30	25	37	D606 191 + D290 287
T130 / ECT130	M ²	115	164	97	40	32	40	D606 159

¹ To be able to mount a type L joint, the actuator must be equipped with a type S adapter (see page 55). This joint is not possible to mount on a T13xxxxx50 type of actuator.

² To be able to mount a type M joint, the actuator must be equipped with a type U adapter (see page 55).



Options and Accessories

Flanges and Gears

BS40 / BS50 Worm Gears

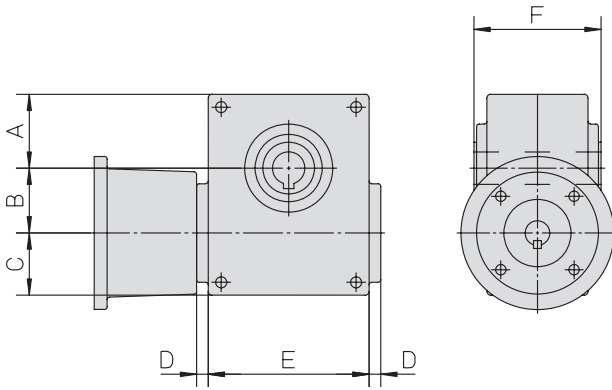

The worm gear includes a gear, bell house and matching coupling but no adaptor flange. The worm gear is ordered using the ordering keys on the right page. The adaptor flange is ordered separately using the part numbers below as there are different adaptor flanges depending on the type of unit being used.

Dimensions

Gear	A	B	C	D	E	F
BS40	54	40	46	10	100	92
BS50	57	50	48	10	124	98

Compatibility

Unit	BS40	BS50	IEC71B14	IEC80B14	IEC90B14	A	L
T90 (T09xxxxxB32)	•		•			17	58
T90 (T09xxxxxB32)	•			•		17	68
T130		•	•			17	78
T130		•		•		17	88
T130		•			•	17	98

Adaptor Flanges

Unit	p/n
T90 (T09xxxxxB32)	D606 227
T130	D606 187

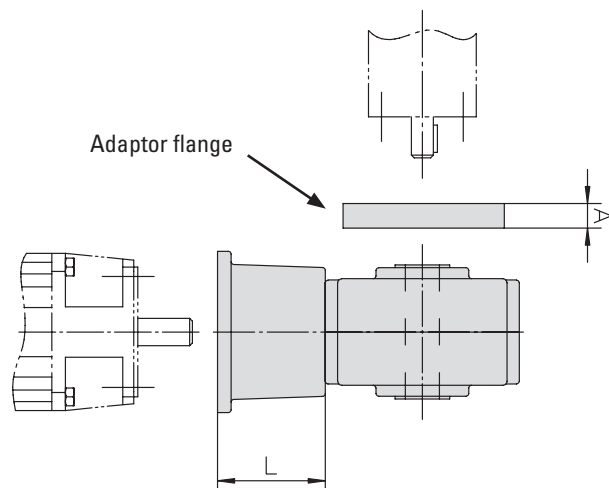

Options and Accessories

Flanges and Gears

BS40 / BS50 Worm Gears

BS40 Ordering Key

1	2	3
BS40	-10	-71
1. Type and size of worm gear BS40 = BS40 worm gear	2. Gear ratio -3 = 3:1 -5,5 = 5,5:1 -7,5 = 7,5:1 -10 = 10:1 -15 = 15:1 -20 = 20:1 -24 = 24:1 -30 = 30:1 -40 = 40:1 -48 = 48:1 -60 = 60:1	6. Motor size -71 = IEC71B14 -80 = IEC80B14

BS50 Ordering Key

1	2	3
BS50	-37	-90
1. Type and size of worm gear BS50 = BS50 worm gear	2. Gear ratio -8 = 8:1 -10,5 = 10,5:1 -14 = 14:1 -21 = 21:1 -24 = 24:1 -32 = 32:1 -37 = 37:1 -42 = 42:1 -54 = 54:1 -64 = 64:1 -81 = 81:1	6. Motor size -71 = IEC71B14 -80 = IEC80B14 -90 = IEC90B14



Options and Accessories

Flanges and Gears

TBS40 Worm Gear

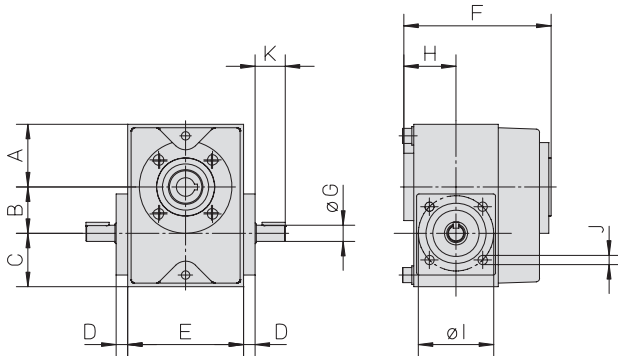

The worm gear is installed directly to the unit and requires no intermediate coupling between the two. To install the gear to the motor, a bell house flange must be used between the gear and the motor. The bell house flange, which includes a matching coupling, is ordered separately. A shaft cover can be ordered to cover the second primary shaft on the gear in case it is not being used.

Dimensions

Gear	A	B	C	D	E	F	øG	H	øI	J	K
TBS40	54	40	46	10	100	125	14j6	45	65	M8 (4x)	25

Compatibility

Unit	TBS40	IEC71B14	IEC80B14	A	L
T60 / T90 (T09xxxxxB25)	•	•		32	58
T60 / T90 (T09xxxxxB25)	•		•	32	68

Bell House Flange

Motor size	p/n
IEC71B14	D701 011
IEC80B14	D701 015

Shaft Cover

Gear type	p/n
TBS40	D701 020

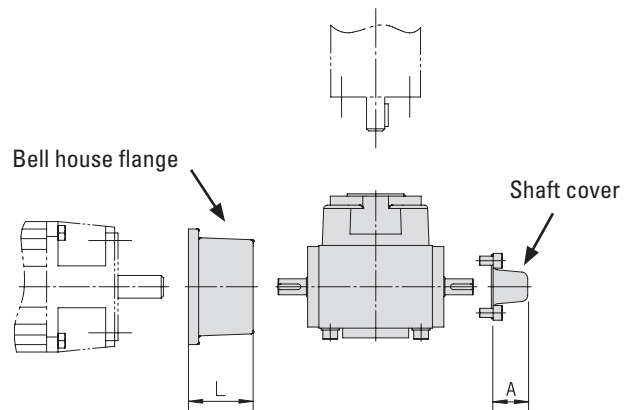

Options and Accessories

Flanges and Gears

TBS40 Worm Gear

Ordering Key

1	2	3
TBS40	-3	-216
1. Type and size of worm gear TBS40 = TBS40 worm gear	2. Gear ratio -3 = 3:1 -5,5 = 5,5:1 -7,5 = 7,5:1 -10 = 10:1 -15 = 15:1 -20 = 20:1 -24 = 24:1 -30 = 30:1 -40 = 40:1 -48 = 48:1 -60 = 60:1	3. Fixed code -216



Options and Accessories

Flanges and Gears

SB Worm Gear

SB030

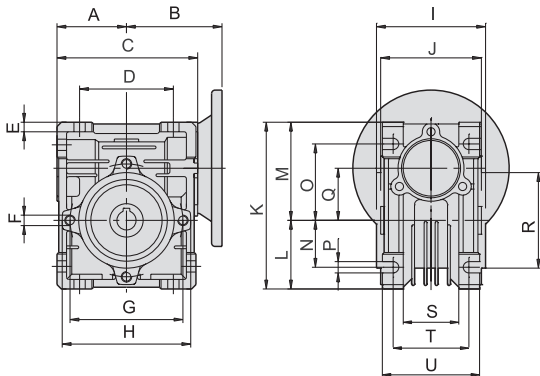

SB040, SB050, SB063, SB075

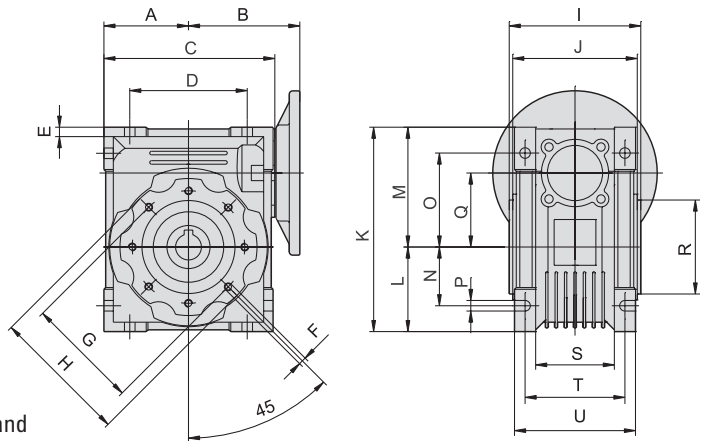

The worm gear is installed to the unit using a unit type and gear-size-specific adapter flange. No intermediate coupling is needed. The gear mounts directly to the motor and no coupling, bell house or adaptor flange is required. An optional rear clevis can be mounted to the gear by using a rear clevis adaptor flange. This can be ordered as a package either unmounted or mounted to the unit, or as separate items.

Dimensions

Gear size	A	B	C	D	E	F	G	H	I	J	K	L	M	N	O	P	Q	R	S	T	U
SB030	40	55	81	54	5.5	M6 × 11	65	75	63	58	97	40	57	27	44	6.5	30	55h8	32	44	56
SB040	50	70	101	70	6.5	M6 × 8	75	87	78	73	121.5	50	71.5	35	55	6.5	40	60h8	43	60	71
SB050	60	80	121	80	7	M8 × 10	85	100	92	87	144	60	84	40	64	8.5	50	70h8	49	70	85
SB063	72	95	146	100	8	M8 × 14	95	110	112	106	174	72	102	50	80	8.5	63	80h8	67	85	103
SB075	86	112.5	174	120	10	M8 × 14	115	140	120	114	205	86	119	60	93	11.5	75	95h8	72	90	112

Unit and Gear Compatibility

Unit type	Gear				
	SB030	SB040	SB050	SB063	SB075
T60 (T06SXXXXG25)	•				
T60 (T06SXXXXH25)		•			
T90 (T09SXXXXH25)		•			
T90 (T09SXXXXL32)			•	•	
T130 (T13SXXXXL40)				•	
T130 (T13SXXXXK50)					•

Options and Accessories

Flanges and Gears

SB Worm Gear

Gear, Gear Ratio and Motor Compatibility

Gear size	Motor size	Gear Ratio [i]											
		5	7.5	10	15	20	25	30	40	50	60	80	100
SB030	IEC56B14	•	•	•	•	•	•	•	•	•	•	•	
	IEC63B14	•	•	•	•	•	•	•	•	•			
SB040	IEC63B14	•	•	•	•	•	•	•	•	•	•	•	•
	IEC71B14	•	•	•	•	•	•	•	•				
SB050	IEC71B14	•	•	•	•	•	•	•	•	•	•	•	
	IEC80B14	•	•	•	•	•	•	•					
SB063	IEC71B14								•	•	•	•	•
	IEC80B14		•	•	•	•	•	•	•	•			
	IEC90B14		•	•	•	•	•	•					
SB075	IEC80B14					•	•	•	•	•	•	•	•
	IEC90B14		•	•	•	•	•	•	•				
	IEC100/112B14		•	•	•								

Ordering Key

1	2	3	4	5
SB030-06G	-7.5	-63	-M	-C
1. Worm gear type, size and unit compatibility SB030-06G = SB030, T06SXXXXG25 SB040-06H = SB040, T06SXXXXH25 SB040-09H = SB040, T09SXXXXH25 SB050-09L = SB050, T09SXXXXL32 SB063-09L = SB063, T09SXXXXL32 SB063-13L = SB063, T13SXXXXL40 SB075-13K = SB075, T13SXXXXK50	2. Gear ratio -5 = 5:1 -7.5 = 7.5:1 -10 = 10:1 -15 = 15:1 -20 = 20:1 -25 = 25:1 -30 = 30:1 -40 = 40:1 -50 = 50:1 -60 = 60:1 -80 = 80:1 -100 = 100:1	3. Motor size -56 = IEC56B14 -63 = IEC63B14 -71 = IEC71B14 -80 = IEC80B14 -90 = IEC90B14 -100 = IEC100/112B14	4. Mounting type -M = gear mounted to unit -N = gear not mounted to unit	5. Rear mounting option -X = no rear mounting -C = rear clevis



Options and Accessories

Flanges and Gears

SB Worm Gear

Gear to Unit Adaptor Flanges

Unit type	Gear size	p/n	A [mm]
T60 (T06SXXXXG25)	SB030	D321823	22
T60 (T06SXXXXH25)	SB040	D321978	25
T90 (T09SXXXXH25)	SB040	D321978	25
T90 (T09SXXXXL32)	SB050	D322130	56
T90 (T09SXXXXL32)	SB063	D322050	56
T130 (T13SXXXXL40)	SB063	D322135	56
T130 (T13SXXXXK50)	SB075	D322118	56

Gear to Rear Clevis Adaptor Flanges

Gear size	p/n	B [mm]
SB030	D390075	14
SB040	D322132	14
SB050	D322124	15
SB063	D322125	15
SB075	D322119	25

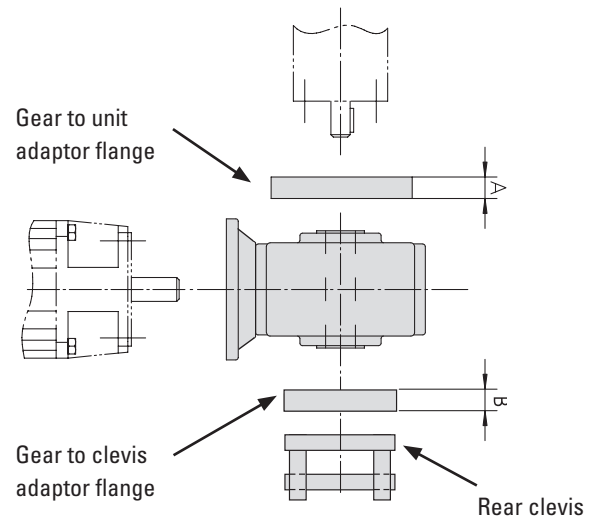

Options and Accessories

Flanges and Gears

SB Worm Gear

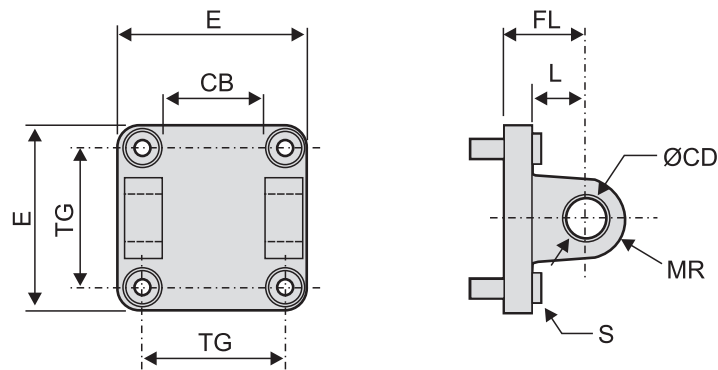

Rear Clevis

Gear size	p/n	CB [mm]	ØCD [mm]	E [mm]	FL [mm]	L [mm]	MR [mm]	S	TG [mm]
SB030	D701982	40	16	75	32 ± 0.2	21	16	M8 × 20	56.5 ± 0.2
SB040	D702169	50	16	95	36 ± 0.2	22	16	M10 × 25	72 ± 0.2
SB050, SB063	D702170	70	25	140	50 ± 0.3	30	25	M12 × 25	110 ± 0.3
SB075	D606576	90	30	180	55 ± 0.2	35	25	M16 × 30	140 ± 0.2

Options and Accessories

Flanges and Gears

BGM Belt Gear

The belt gear comes in parts and is assembled and mounted to the unit and motor by the customer.

BGM06/09/41/81 - NO CLEVIS OPTION

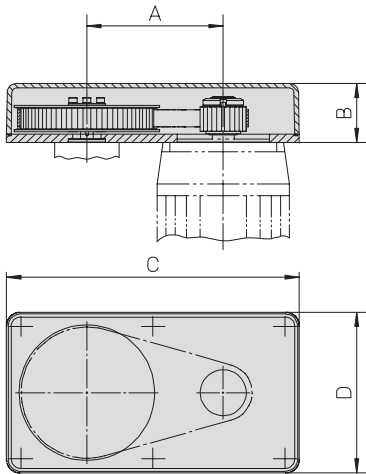

BGM09/41/81 - CLEVIS OPTION TYPE S

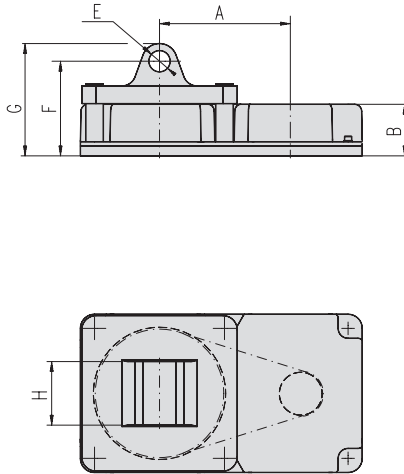

BGM06/81 - CLEVIS OPTION TYPE R

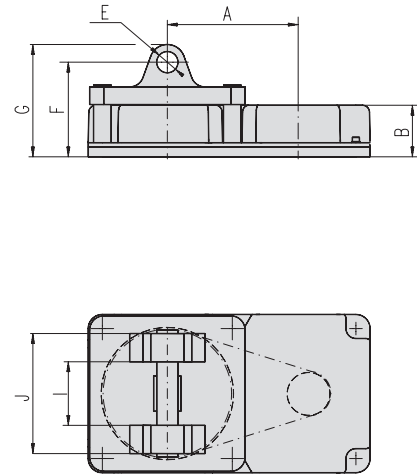

Dimensions

Gear	A	B	C	D	øE	F	G	H	I	J
BGM06	72,5	50	152	95	16 H9	82	98	–	40	70
BGM09	118,7	52	255	140	20 H9	95	115	60	–	–
BGM41	155,2	70	305	165	25 H9	122	147	70	–	–
BGM81	200	73	399	224	30 H9	134	159	90	90H14	170

Technical Data

Gear	i	n_{max} [rpm]	M_{max} [Nm]	η	J [kgm ²]	Weight [kg]
BGM06	1:1	4000	2,1	0,85	0,000076	1,6
BGM06	2:1	4000	3,4	0,85	0,000100	1,7
BGM09	1,04:1	4000	3,3	0,85	0,000102	2
BGM09	1,85:1	4000	3,3	0,85	0,000112	2,1
BGM09	2,85:1	4000	3,3	0,85	0,000213	2,5
BGM41	1:1	4000	16,6	0,85	0,000438	3,4
BGM41	2:1	4000	9,7	0,85	0,000342	3,7
BGM41	3:1	4000	9,7	0,85	0,000583	4,6
BGM81	1:1	4000	32	0,85	0,000836	12,1
BGM81	2,25:1	4000	30	0,85	0,001051	12,9
BGM81	3,13:1	4000	28	0,85	0,001439	14

i = gear ratio, n_{max} = max. input speed, M_{max} = max. input torque, η = efficiency factor, J = inertia

Options and Accessories

Flanges and Gears

BGM Belt Gear

BGM Compatibility

Gear	T60	T90 (T09-B25)	T90 (T09-B32)	T130
BGM06	•			
BGM09	•	•		
BGM41		•	•	•
BGM81				•

BGM Ordering Key

1	2	3	4	5	6	7	8
BGM09	-2	-CC	063	P	09A	X	+XX

1. Type and size of belt gear

BGM06 = BGM belt gear size 06
 BGM09 = BGM belt gear size 09
 BGM41 = BGM belt gear size 41
 BGM81 = BGM belt gear size 81

2. Gear ratio

-1 = see table below
 -2 = see table below
 -3 = see table below

Gear ratio code	Belt gear type			
	BGM06	BGM09	BGM41	BGM81
-1	1:1	1,04:1	1:1	1:1
-2	2:1	1,85:1	2:1	2,25:1
-3	–	2,85:1	3:1	3,13:1

3. Type of couplings

-CC = conical couplings

4. Motor size compatibility ¹

063 = IEC 63 B14
 071 = IEC 71 B14
 080 = IEC 80 B14
 090 = IEC 90 B14
 100 = IEC 100/121 B14
 S80 = servo motor size 80
 S95 = servo motor size 95
 A20 = servo motor size A200
 AK3 = servo motor type AKM 3
 AK4 = servo motor type AKM 4
 AK5 = servo motor type AKM 5
 AK6 = servo motor type AKM 6

Motor code	Belt gear type			
	BGM06	BGM09	BGM41	BGM81
063		•		
071		•	•	
080			•	
090			•	•
100				•
S80		•	•	
S95				
A20			•	•
AK3	•			
AK4	•	•		
AK5			•	
AK6				•

5. Type of mounting

P = standard

6. Compatible unit

T06 = T60
 09A = T90 (T09-B25)
 09B = T90 (T09-B32)
 130 = T130

Unit code	Belt gear type			
	BGM06	BGM09	BGM41	BGM81
T06	•	•		
09A		•	•	
09B			•	
130			•	•

7. Clevis option compatibility

X = no clevis option
 S = clevis option type S
 R = clevis option type R

Clevis code	Belt gear typ			
	BGM06	BGM09	BGM41	BGM81
X	•	•	•	•
S		•	•	•
R	•			•

8. Protection

+XX = standard
 +S1 = wash down protection

(1) This is only a selection of all motors that fit the gears. Please contact customer support to see if your preferred motor fits the gear.



Options and Accessories

Motors

Three-Phase AC Induction Motor with/without Brake

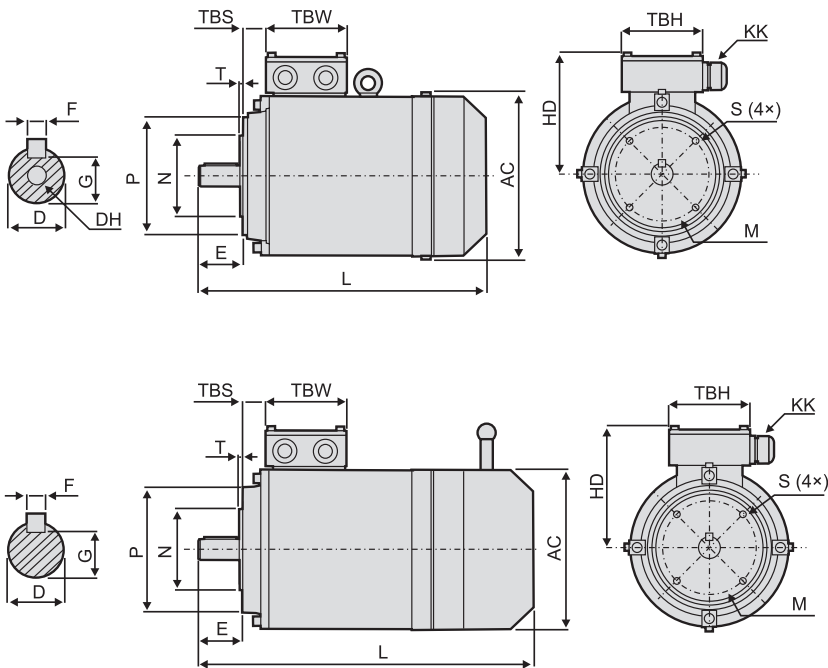

Please contact Thomson Customer Service for available motors.

Options and Accessories

Sensors

Magnetic Sensors Option

Technical Specifications

Parameter		
Max. power	[W]	10
Max. voltage	[Vdc]	100
Max. current	[A]	0,5
LED indicator for switch		no
Protection class		IP67
Cable length	[m]	3
Cable cross section	[mm ²]	2 × 0,15
Operating temperature limits	[°C]	-25 – 65
Weight	[kg]	0,050

Part Numbers

Sensor type	Suitable units	p/n
Normally closed	T60, T90, T130, ECT90, ECT130	D535 071
Normally open	T60, T90, T130, ECT90, ECT130	D535 070

The magnetic sensors are mounted directly in the sensor slots on both sides of the profile of the units. They require no additional mounting bracket. The sensor is fixed in position by two M3 size locking screws (A1). The cable (A2) is molded into the sensor. Up to nine normally open and nine normally closed sensors can be ordered to the unit using the ordering key. These sensors will be shipped with the unit but not mounted to the unit. Extra sensors can be ordered using the part numbers.

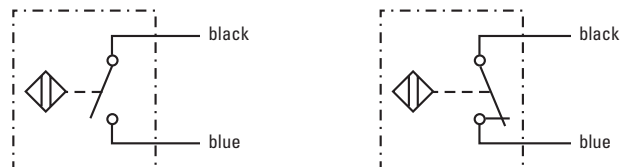
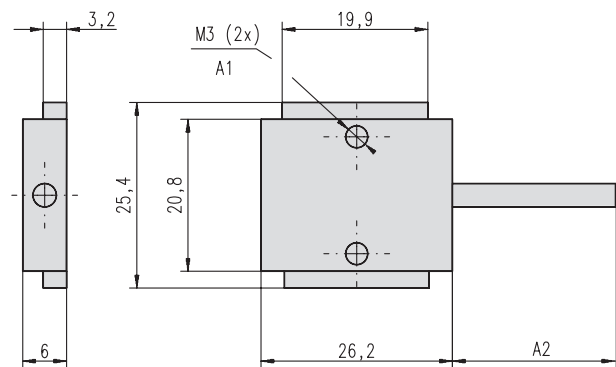



Options and Accessories

Environmental Protection

Environment Protection Option S1

Technical Specifications

Item	S1
External screws, bolts, nuts and washers	stainless class A2
Extension tube rod end	standard class A2

The S1 environment protection option will enhance the unit's ability to withstand harsh environments where water, acids and basic agents are present. All performance data and life expectancy are the same as for standard units.

S1 - Washdown protection

Typical places where S1 is used include slaughter houses, dairy and food plants, or in any other light washdown application.

Options and Accessories

Shafts and Flanges for Non-RediMount™ Units

T60

T06SXXXXB25

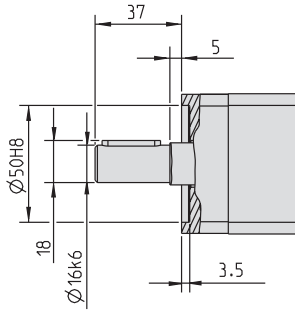

T06SXXXXG25

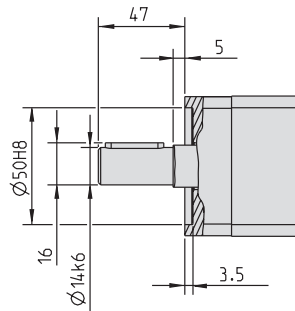

T06SXXXXH25

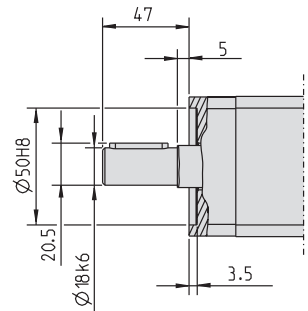

T06SXXXXB25/G25

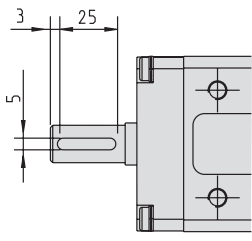

T06SXXXXH25

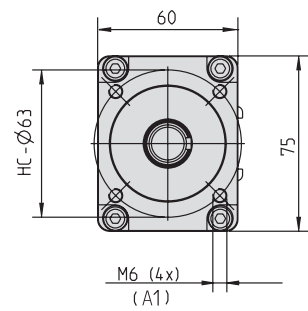
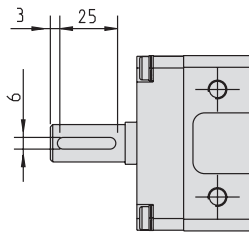

A1: depth 20

T90

T09SXXXXB25

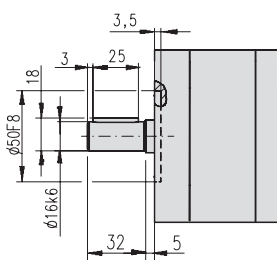

T09SXXXXH25

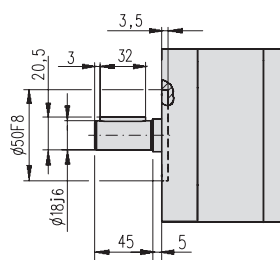

T09SXXXXB32

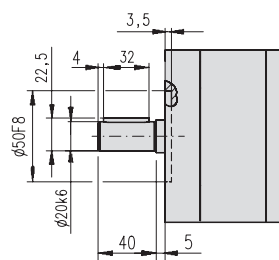

T09SXXXXL32

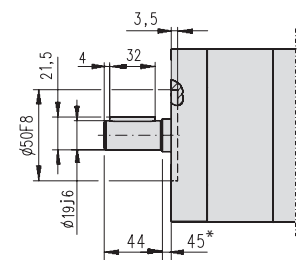

* drawing does not fully match the actual dimensions.

T09SXXXXB25/H25

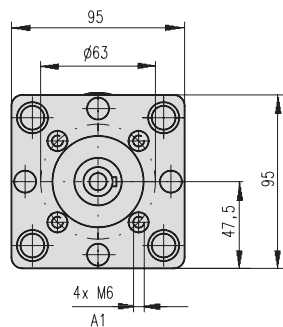
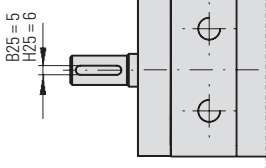

T09SXXXXB32/L32

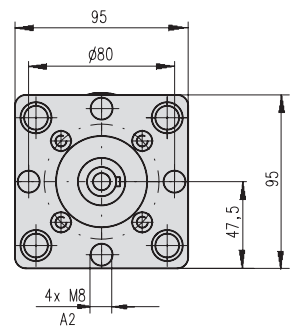
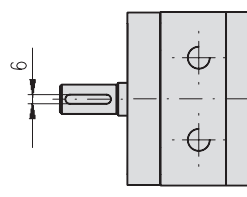

A1: depth 18, A2: depth 43



Options and Accessories

Shafts and Flanges for Non-RediMount™ Units

T130

T13SXXXXB40

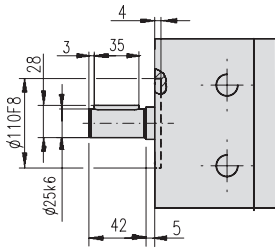

T13SXXXXL40

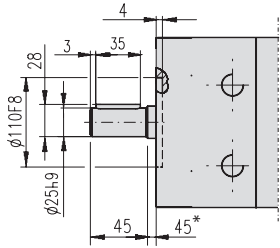

* drawing does not fully match the actual dimensions.

T13SXXXXB50

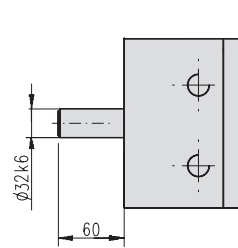

T13SXXXXK50

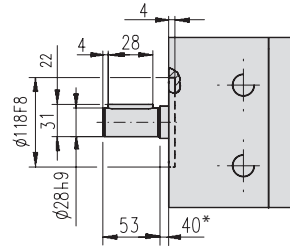

* drawing does not fully match the actual dimensions.

T13SXXXXB40/L40

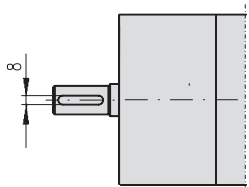

A1: depth 20

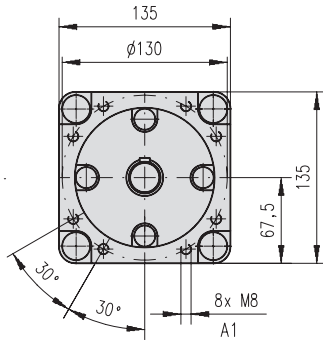

T13SXXXXB50/K50

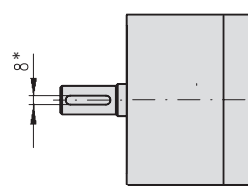

* no key way on T13xxxxxB50

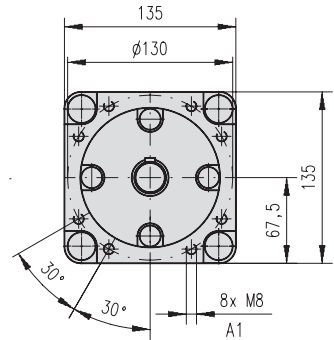

Ordering Keys

How to Order

When ordering a Thomson precision linear actuator, it is necessary to first make sure that the proper sizing and selection has been done. The demand on your system will impact your choice of stroke length, profile size, belt or screw drive, environmental protection demands, etc.

The load and speed demand will tell you the configuration of gearboxes, drive shafts and motor attachment accessories that are necessary. You will also need to evaluate what accessories and options are necessary.



Thomson will assist you in the sizing and selection work and determining of part numbers, but it is important that you are aware of the demands of your specific application in order to enable us to supply you with the correct unit.

On the following pages you will find the ordering keys for the different T and ECT Series precision linear actuators shown in earlier pages. These keys are self-explanatory and by following the examples, you can quickly and easily learn about the different options and versions available. Please also visit www.thomsonlinear.com where you can find information and CAD drawings that make the selection, ordering and design process much easier. Please contact us for further support.



Ordering Keys

T60, T90 and T130

T60, T90 and T130								
1	2	3	4	5	6	7	8	9
T09	LX	GB8	B	3210	-00750	X	R	XX
<p>1. Type of unit T06 = T60 unit T09 = T90 unit T13 = T130 unit</p> <p>2. Transmission type LX = inline style, directly coupled, RediMount flange SX = inline style, directly coupled, no RediMount flange</p> <p>3. RediMount motor ID code XXX = for units without RediMount flange vww = alphanumeric motor code for suitable RediMount flange when motor is known ?? 999 = code used when motor is unknown</p> <p>4. Drive shaft type B = standard (for SX units with standard shaft and all LX units) G = shaft for SB030 worm gear (only possible on T06SXXXXx25xx units) H = shaft for SB040 worm gear (only possible on T06SXXXXx25xx and T09SXXXXx25xx units) K = shaft for SB075 worm gear (only possible on T13SXXXXx5010 units) L = shaft for SB050 (only possible on T09SXXXXx32xx) and SB063 (only possible on T09SXXXXx32xx and T13SXXXXx40xx)</p> <p>5. Screw type, diameter, lead 2505 = ballscrew, 25 mm, 5 mm (only possible for T06 and T09 units) 2510 = ballscrew, 25 mm, 10 mm (only possible for T06 and T09 units) 2525 = ballscrew, 25 mm, 25 mm (only possible for T06 and T09 units) 2550 = ballscrew, 25 mm, 50 mm (only possible for T06 units) 3210 = ballscrew, 32 mm, 10 mm (only possible for T09 units) 3220 = ballscrew, 32 mm, 20 mm (only possible for T09 units) 3232 = ballscrew, 32 mm, 32 mm (only possible for T09 units) 4010 = ballscrew, 40 mm, 10 mm (only possible for T13 units) 4020 = ballscrew, 40 mm, 20 mm (only possible for T13 units) 4040 = ballscrew, 40 mm, 40 mm (only possible for T13 units) 5010 = ballscrew, 50 mm, 10 mm (only possible for T13 units)</p>					<p>6. Maximum stroke (Smax) - xxxxx = distance in mm</p> <p>7. Mounting options X = no mounting option F = mounting feet (movable for T60 and fixed for T90 and T130) T = trunnion G = front mounting plate</p> <p>8. Adapter options J = spherical joint ø16 mm (only possible for T06xxxxx25 and T09xxxxx25) K = spherical joint ø20 mm (only possible for T09xxxxx32) L = spherical joint ø30 mm (only possible for T13xxxxx40) M = spherical joint ø40 mm (only possible for T13xxxxx50) N = M16 × 1,5 outside thread (only possible for T06xxxxx25 and T09xxxxx25) P = M16 × 2 inside thread (only possible for T06xxxxx25 and T09xxxxx25) Q = M20 × 1,5 outside thread (only possible for T09xxxxx32) R = M20 × 1,5 inside thread (only possible for T09xxxxx32) S = M27 × 2 outside thread (only possible for T13xxxxx40) T = M27 × 2 inside thread (only possible for T13xxxxx40) U = M33 × 2 outside thread (only possible for T13xxxxx40 and T13xxxxx50) V = M33 × 2 inside thread (only possible for T13xxxxx40 and T13xxxxx50) X = M30 × 2 inside thread (only possible for T13xxxxx40)</p> <p>9. Protection option XX = standard S1 = wash down protection</p> <p>¹ See below for the definition of drive flange type.</p>			
<p>With RediMount (LX)</p> 					<p>Without RediMount (SX)</p> 			

Ordering Keys

ECT90

ECT90 - Parallel IEC90 AC Motor							
1	2	3	4	5	6	7	8
ECT09-I	09B02PB2510	-1500	X	J	0	2	XX
1. Model and motor type ECT09-I = ECT90 with IEC90 three phase AC motor 2. Max. load, speed, gear type, brake and motor style 09B03PB2510 = 9750 N, 160 mm/s, belt gear, brake, parallel ¹ 09B02PB2510 = 6500 N, 240 mm/s, belt gear, brake, parallel ¹ 09B03PB3220 = 4800 N, 320 mm/s, belt gear, brake, parallel ¹ 09B02PB3220 = 3100 N, 480 mm/s, belt gear, brake, parallel ² 09B01PB3220 = 1600 N, 960 mm/s, belt gear, brake, parallel ² 09B01PB3232 = 900 N, 1520 mm/s, belt gear, brake, parallel ²		3. Stroke (S max) - xxxx = distance in mm 4. Mounting options X = no mounting option S = clevis F = mounting feet T = trunnion G = front mounting plate 5. Adapter options J = spherical joint ø16 mm K = spherical joint ø20 mm N = outside thread M16 × 1,5 P = inside thread M16 × 2 Q = outside thread M20 × 1,5 R = inside thread M20 × 1,5		6. Magnetic sensors N.C ³ y = number of normally closed sensors (0 - 9) 7. Magnetic sensors N.O ³ z = number of normally open sensors (0 - 9) 8. Protection options ⁴ XX = standard S1 = wash down protection ¹ These models are only compatible with adapter options J, N and P. ² These models are only compatible with adapter options K, Q and R. ³ The sensors are shipped unmounted with the unit. ⁴ See page 73 for more information.			

ECT90 - Parallel B43 or B53 AC Servo Motor							
1	2	3	4	5	6	7	8
ECT09-B	53R03PB3220	-1340	S	Q	3	0	S1
1. Model and motor type ECT09-B = ECT90 with AC servo motor 2. Max. load, speed, gear type, brake and motor style 53R03PB2510 = 9800 N, 220 mm/s, belt gear, no brake, parallel ¹ 53R02PB2510 = 8000 N, 330 mm/s, belt gear, no brake, parallel ¹ 53R03PB3220 = 5900 N, 440 mm/s, belt gear, no brake, parallel ² 43R03PB2510 = 5800 N, 140 mm/s, belt gear, no brake, parallel ¹ 53R02PB3220 = 3900 N, 670 mm/s, belt gear, no brake, parallel ² 43R02PB2510 = 3800 N, 210 mm/s, belt gear, no brake, parallel ¹ 43R03PB3220 = 2800 N, 270 mm/s, belt gear, no brake, parallel ² 43R02PB3220 = 1800 N, 420 mm/s, belt gear, no brake, parallel ² 53S03PB2510 = 9800 N, 220 mm/s, belt gear, brake, parallel ¹ 53S02PB2510 = 8000 N, 330 mm/s, belt gear, brake, parallel ¹ 53S03PB3220 = 5900 N, 440 mm/s, belt gear, brake, parallel ² 43S03PB2510 = 5800 N, 140 mm/s, belt gear, brake, parallel ¹ 53S02PB3220 = 3900 N, 670 mm/s, belt gear, brake, parallel ² 43S02PB2510 = 3800 N, 210 mm/s, belt gear, brake, parallel ¹ 43S03PB3220 = 2800 N, 270 mm/s, belt gear, brake, parallel ² 43S02PB3220 = 1800 N, 420 mm/s, belt gear, brake, parallel ²		3. Stroke (S max) - xxxx = distance in mm 4. Mounting options X = no mounting option S = clevis F = mounting feet T = trunnion G = front mounting plate 5. Adapter options J = spherical joint ø16 mm K = spherical joint ø20 mm N = outside thread M16 × 1,5 P = inside thread M16 × 2 Q = outside thread M20 × 1,5 R = inside thread M20 × 1,5		6. Magnetic sensors N.C ³ y = number of normally closed sensors (0 - 9) 7. Magnetic sensors N.O ³ z = number of normally open sensors (0 - 9) 8. Protection options ⁴ XX = standard S1 = wash down protection ¹ These models are only compatible with adapter options J, N and P. ² These models are only compatible with adapter options K, Q and R. ³ The sensors are shipped unmounted with the unit. ⁴ See page 73 for more information.			



Ordering Keys

ECT90

ECT90 - Direct Drive, Inline B43 or B53 AC Servo Motor

1	2	3	4	5	6	7	8
ECT09-B	53R01LD2510	-0800	T	P	0	0	S1
1. Model and motor type ECT09-B = ECT90 with AC servo motor 2. Max. load, speed, gear type, brake and motor style 53R01LD2510 = 5300 N, 450 mm/s, direct drive, no brake, inline ¹ 53R01LD3220 = 2600 N, 1000 mm/s, direct drive, no brake, inline ² 43R01LD2510 = 2000 N, 410 mm/s, direct drive, no brake, inline ¹ 53R01LD3232 = 1500 N, 1600 mm/s, direct drive, no brake, inline ² 43R01LD3220 = 900 N, 820 mm/s, direct drive, no brake, inline ² 53S01LD2510 = 5300 N, 450 mm/s, direct drive, brake, inline ¹ 53S01LD3220 = 2600 N, 1000 mm/s, direct drive, brake, inline ² 43S01LD2510 = 2000 N, 410 mm/s, direct drive, brake, inline ¹ 53S01LD3232 = 1500 N, 1600 mm/s, direct drive, brake, inline ² 43S01LD3220 = 900 N, 820 mm/s, direct drive, brake, inline ²		3. Stroke (S max) - xxxx = distance in mm 4. Mounting options X = no mounting option F = mounting feet T = trunnion G = front mounting plate 5. Adapter options J = spherical joint ø16 mm K = spherical joint ø20 mm N = outside thread M16 × 1,5 P = inside thread M16 × 2 Q = outside thread M20 × 1,5 R = inside thread M20 × 1,5		6. Magnetic sensors N.C ³ y = number of normally closed sensors (0 - 9) 7. Magnetic sensors N.O ³ z = number of normally open sensors (0 - 9) 8. Protection options ⁴ XX = standard S1 = wash down protection ¹ These models are only compatible with adapter options J, N and P. ² These models are only compatible with adapter options K, Q and R. ³ The sensors are shipped unmounted with the unit. ⁴ See page 73 for more information.			

ECT90 - Planetary Gear, Inline B43 or B53 AC Servo Motor

1	2	3	4	5	6	7	8
ECT09-B	43R10LP3220	-1205	X	R	9	2	XX
1. Model and motor type ECT09-B = ECT90 with AC servo motor 2. Max. load, speed, gear type, brake and motor style 53R10LP3220 = 20000 N, 130 mm/s, planetary gear, no brake, inline 53R05LP3220 = 13000 N, 270 mm/s, planetary gear, no brake, inline 43R10LP3220 = 10000 N, 80 mm/s, planetary gear, no brake, inline 43R05LP3220 = 5000 N, 160 mm/s, planetary gear, no brake, inline 53S10LP3220 = 20000 N, 130 mm/s, planetary gear, brake, inline 53S05LP3220 = 13000 N, 270 mm/s, planetary gear, brake, inline 43S10LP3220 = 10000 N, 80 mm/s, planetary gear, brake, inline 43S05LP3220 = 5000 N, 160 mm/s, planetary gear, brake, inline		3. Stroke (S max) - xxxx = distance in mm 4. Mounting options X = no mounting option F = mounting feet T = trunnion G = front mounting plate 5. Adapter options K = spherical joint ø20 mm Q = outside thread M20 × 1,5 R = inside thread M20 × 1,5		6. Magnetic sensors N.C ¹ y = number of normally closed sensors (0 - 9) 7. Magnetic sensors N.O ¹ z = number of normally open sensors (0 - 9) 8. Protection options ² XX = standard S1 = wash down protection ¹ The sensors are shipped unmounted with the unit. ² See page 73 for more information.			

Ordering Keys

ECT130

ECT130 - Parallel IEC100 AC Motor							
1	2	3	4	5	6	7	8
ECT13-I	10B03PB4010	-1850	R	V	1	0	S1
1. Model and motor type ECT13-I = ECT130 with IEC100 three phase AC motor		3. Stroke (S max) - xxxx = distance in mm		6. Magnetic sensors N.C¹ y = number of normally closed sensors (0 - 9)			
2. Max. load, speed, gear type, brake and motor style 10B03PB4010 = 13300 N, 175 mm/s, belt gear, brake, parallel 10B02PB4010 = 9400 N, 210 mm/s, belt gear, brake, parallel 10B03PB4020 = 6200 N, 300 mm/s, belt gear, brake, parallel 10B02PB4020 = 4200 N, 420 mm/s, belt gear, brake, parallel 10B01PB4020 = 1800 N, 950 mm/s, belt gear, brake, parallel 10B01PB4040 = 600 N, 1900 mm/s, belt gear, brake, parallel		4. Mounting options X = no mounting option R = clevis F = mounting feet T = trunnion G = front mounting plate		7. Magnetic sensors N.O¹ z = number of normally open sensors (0 - 9)		8. Protection options² XX = standard S1 = wash down protection	
		5. Adapter options L = spherical joint ø30 mm M = spherical joint ø40 mm S = outside thread M27 × 2 T = inside thread M27 × 2 U = outside thread M33 × 2 V = inside thread M33 × 2 X = inside thread M30 × 2		¹ The sensors are shipped unmounted with the unit.		² See page 73 for more information.	

ECT130 - Parallel B53 or B63 AC Servo Motor							
1	2	3	4	5	6	7	8
ECT13-B	53R02PB4020	-2000	X	U	0	0	XX
1. Model and motor type ECT13-B = ECT130 with AC servo motor		3. Stroke (S max) - xxxx = distance in mm		6. Magnetic sensors N.C¹ y = number of normally closed sensors (0 - 9)			
2. Max. load, speed, gear type, brake and motor style 63R03PB4010 = 21500 N, 160 mm/s, belt gear, no brake, parallel 63R02PB4010 = 15500 N, 220 mm/s, belt gear, no brake, parallel 53R03PB4010 = 15000 N, 160 mm/s, belt gear, no brake, parallel 63R03PB4020 = 10500 N, 320 mm/s, belt gear, no brake, parallel 53R02PB4010 = 10500 N, 220 mm/s, belt gear, no brake, parallel 63R02PB4020 = 7500 N, 440 mm/s, belt gear, no brake, parallel 53R03PB4020 = 7000 N, 320 mm/s, belt gear, no brake, parallel 53R02PB4020 = 5000 N, 440 mm/s, belt gear, no brake, parallel 63S03PB4010 = 21500 N, 160 mm/s, belt gear, brake, parallel 63S02PB4010 = 15500 N, 220 mm/s, belt gear, brake, parallel 53S03PB4010 = 15000 N, 160 mm/s, belt gear, brake, parallel 63S03PB4020 = 10500 N, 320 mm/s, belt gear, brake, parallel 53S02PB4010 = 10500 N, 220 mm/s, belt gear, brake, parallel 63S02PB4020 = 7500 N, 440 mm/s, belt gear, brake, parallel 53S03PB4020 = 7000 N, 320 mm/s, belt gear, brake, parallel 53S02PB4020 = 5000 N, 440 mm/s, belt gear, brake, parallel		4. Mounting options X = no mounting option R = clevis F = mounting feet T = trunnion G = front mounting plate		7. Magnetic sensors N.O¹ z = number of normally open sensors (0 - 9)		8. Protection options² XX = standard S1 = wash down protection	
		5. Adapter options L = spherical joint ø30 mm M = spherical joint ø40 mm S = outside thread M27 × 2 T = inside thread M27 × 2 U = outside thread M33 × 2 V = inside thread M33 × 2 X = inside thread M30 × 2		¹ The sensors are shipped unmounted with the unit.		² See page 73 for more information.	



Ordering Keys

ECT130

ECT130 - Direct Drive, Inline B53 or B63 AC Servo Motor

1	2	3	4	5	6	7	8
ECT13-B	53R01LD4040	-1850	X	S	1	1	S1
1. Model and motor type ECT13-B = ECT130 with AC servo motor 2. Max. load, speed, gear type, brake and motor style 63R01LD4010 = 7400 N, 400 mm/s, direct drive, no brake, inline 53R01LD4010 = 4900 N, 400 mm/s, direct drive, no brake, inline 63R01LD4020 = 3400 N, 1000 mm/s, direct drive, no brake, inline 53R01LD4020 = 2250 N, 1000 mm/s, direct drive, no brake, inline 63R01LD4040 = 1400 N, 2000 mm/s, direct drive, no brake, inline 53R01LD4040 = 700 N, 2000 mm/s, direct drive, no brake, inline 63S01LD4010 = 7400 N, 400 mm/s, direct drive, brake, inline 53S01LD4010 = 4900 N, 400 mm/s, direct drive, brake, inline 63S01LD4020 = 3400 N, 1000 mm/s, direct drive, brake, inline 53S01LD4020 = 2250 N, 1000 mm/s, direct drive, brake, inline 63S01LD4040 = 1400 N, 2000 mm/s, direct drive, brake, inline 53S01LD4040 = 700 N, 2000 mm/s, direct drive, brake, inline		3. Stroke (S max) - xxxx = distance in mm 4. Mounting options X = no mounting option F = mounting feet T = trunnion G = front mounting plate 5. Adapter options L = spherical joint ø30 mm M = spherical joint ø40 mm S = outside thread M27 × 2 T = inside thread M27 × 2 U = outside thread M33 × 2 V = inside thread M33 × 2 X = inside thread M30 × 2		6. Magnetic sensors N.C ¹ y = number of normally closed sensors (0 - 9) 7. Magnetic sensors N.O ¹ z = number of normally open sensors (0 - 9) 8. Protection options ² XX = standard S1 = wash down protection ¹ The sensors are shipped unmounted with the unit. ² See page 73 for more information.			

ECT130 - Planetary Gear, Inline B53 or B63 AC Servo Motor

1	2	3	4	5	6	7	8
ECT13-B	63R05LP4010	-0600	F	L	0	5	XX
1. Model and motor type ECT13-B = ECT130 with AC servo motor 2. Max. load, speed, gear type, brake and motor style 53R10LP4010 = 38000 N, 50 mm/s, planetary gear, no brake, inline 63R05LP4010 = 33000 N, 100 mm/s, planetary gear, no brake, inline 53R05LP4010 = 22500 N, 100 mm/s, planetary gear, no brake, inline 63R05LP4020 = 16000 N, 200 mm/s, planetary gear, no brake, inline 53R05LP4020 = 11000 N, 200 mm/s, planetary gear, no brake, inline 53S10LP4010 = 38000 N, 50 mm/s, planetary gear, brake, inline 63S05LP4010 = 33000 N, 100 mm/s, planetary gear, brake, inline 53S05LP4010 = 22500 N, 100 mm/s, planetary gear, brake, inline 63S05LP4020 = 16000 N, 200 mm/s, planetary gear, brake, inline 53S05LP4020 = 11000 N, 200 mm/s, planetary gear, brake, inline		3. Stroke (S max) - xxxx = distance in mm 4. Mounting options X = no mounting option F = mounting feet T = trunnion G = front mounting plate 5. Adapter options L = spherical joint ø30 mm M = spherical joint ø40 mm S = outside thread M27 × 2 T = inside thread M27 × 2 U = outside thread M33 × 2 V = inside thread M33 × 2 X = inside thread M30 × 2		6. Magnetic sensors N.C ¹ y = number of normally closed sensors (0 - 9) 7. Magnetic sensors N.O ¹ z = number of normally open sensors (0 - 9) 8. Protection options ² XX = standard S1 = wash down protection ¹ The sensors are shipped unmounted with the unit. ² See page 73 for more information.			

Glossary

A – Ce

Acceleration

Acceleration is a measure of the rate of speed change going from standstill (or a lower speed) to a higher speed. The calculations, which are used to develop the Load versus Speed diagrams for each actuator, are based on an acceleration rate that is limited by the maximum speed of the unit. Therefore, this value will be different for all actuators. Please contact customer service if your application is critical to which acceleration rate is acceptable or needed. Also see "Deceleration".

Accuracy

There are several types of accuracy and many different factors that will affect the overall accuracy of a system. Also see "Repeatability", "Positioning Accuracy", "Resolution", "Lead Accuracy" and "Backlash".

AC Motor

There are several types of AC motors; all of which run on an applied alternating current. Also see "Three-Phase AC Motor".

AC Servo Motor

AC servo motor is an abbreviation for a brushless, synchronous AC motor design. This type of design requires little mechanical maintenance since no physical contact (no brushes and bars) is used to commutate the motor. This extends the life of the motor and reduces down time. Also see "Brushless AC Servo Motor".

Adapter

The adapter on T and ECT actuators is the connection point for the load and is situated at the end of the extension tube. There are several types of adapters: 1) tapped hole, 2) threaded rod and 3) spherical joint. Also see "Mounting".

Anti-rotation Mechanism

An actuator with anti-rotation mechanism has a built-in feature that prevents the extension tube from rotating if the tube is not attached to any load. All T and ECT actuators have this feature.

Backlash

Backlash is the stack up of tolerances (play) within the leadscrew assembly and gearing, which creates a dead band when changing directions. The result is that the motor can rotate some before any motion can be seen on the extension tube when reversing the direction of the motor rotation. The backlash varies depending of the actuator model, and the amount of backlash for each can be found in the performance specifications. The backlash for ball screw models will remain the same during its life time, while it will increase slightly for acme screws. Direct-driven models normally have less backlash because they do not incorporate any gearing.

Ball Screw

Ball screws (fig. a) are used on all T and ECT actuators. They are highly efficient and can run up at 100% duty cycle. Also see "Duty Cycle".

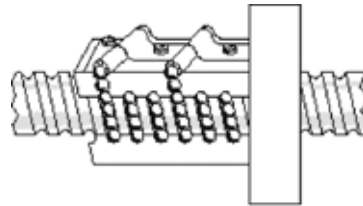

Fig. a

Belt Gear

A belt gear consists of a timing belt that runs between two pulley wheels of different diameter. The difference between the diameters determines the gear ratio. Belt gears are quiet, have medium accuracy, and require no maintenance. However, the belt is susceptible to breakage under overload conditions.

Brake

Acme screws are inherently self-locking, while ball screws are not. To prevent ball screw actuators from backdriving, the actuator may need some type of motor brake depending on the application. A brake can also be used to stop the actuator quickly and safely in emergency situations. Precision linear actuators with DC motors do not have optional brakes, so an alternative solution must be sought. All asynchronous, three-phase AC motors come equipped with an electrically released, fail-safe brake (optional for brushless AC servo motors).

Brushless AC Servo Motor

A brushless AC servo motor has many advantages over DC and asynchronous, three-phase AC motors. For a given power rating, they are smaller and can typically travel at higher speeds and acceleration rates (due to a lower rotor inertia). Unlike DC motors, AC servo motors have no brushes for commutation; therefore, they are almost maintenance free. Instead, they incorporate a resolver feedback device that feeds a shaft-position signal to the drive control for commutation. The drive control also converts the resolver signal into a simulated encoder pulse train that can be used to feed a positioning controller. Also see "Three-Phase AC Motor", "Servo Motor" and "Servo Drive".

Certificates

All T and ECT actuators sold in the EU are CE certified. Please contact customer service if you need any other type of certificate.

Glossary

Co – Du

Column Load Limit

The column load limit is the maximum compression force that the lead screw can handle before it becomes damaged (Fig. b). The limit is a function of the screw diameter and the unsupported length of the screw, which means that the limit will drop as the extension tube extends. For some actuators this means that the allowed maximum dynamic load found in the performance specifications can be higher than the column load limit when the extension tube travel is beyond a certain distance. In this case, either the load must be reduced to the column load limit, the amount of used stroke must be reduced, or you must select another actuator model that can manage the column load at that stroke. The column load force limits can be found in the “Column Load vs. Stroke” diagram on the product pages for each actuator. Also see “Dynamic Load Rating”.

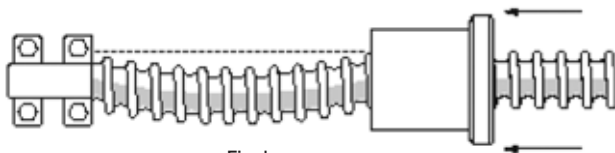

Fig. b

Controls

There are many types of programmable controls that can be used to control the motion of the actuator. PLC, motion controls, robot controls, CNC controls and industrial computers are just some of them. Many types of servo drives have built-in (or as an expansion card option) programmable motion control features. Thomson offers a variety of combinations to serve your motion control needs.

Cover Tube

The cover tube provides protection for the ball or acme screw and provides protection and support for the extension tube. The cover tube on T and ECT actuators are designed so that magnetic sensors easily can be mounted to the outside of the tube. Also see “Extension Tube” and “Magnetic Sensors”.

Critical Speed

All ball screws have a critical speed where the screw starts to vibrate and eventually bend or warp the screw (Fig. c). The exact limit is a function of how far out the extension tube is run and speed. For some actuators this means that the allowed maximum speed found in the performance specifications can be higher than the critical speed when the extension tube travel is beyond a certain distance. In this case, either the speed must be reduced to the critical speed, the amount of stroke must be reduced, or you must select another actuator model that can manage the speed at that stroke. The critical speed limits can be found in the “Critical Speed vs. Stroke” diagram on the product pages for each actuator. Also see “Speed Rating”.

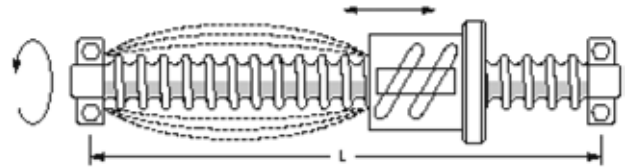

Fig. c

Customization

Even the most versatile standard actuator may not always suit all applications. But whatever your need is, our engineers are ready to help you to customize the actuators according to your requirements. We build more exclusive actuators than anyone in the business and have decades of experience in customizing actuators to meet special needs.

Cycle

One cycle is one complete extension and retraction of the extension tube.

Deceleration

Deceleration is a measure of the rate of speed change going from a higher speed to a lower speed (or standstill). The calculations, which are used to develop the Load versus Speed diagrams for each actuator, are based on a deceleration rate that is limited by the maximum speed of the unit. Therefore, this value will be different for all actuators. Please contact customer service if your application is critical to which deceleration rate is acceptable or needed. Also see “Acceleration”.

Direct Drive

Direct drive means that there is no gearing between the motor and the lead screw. Instead, the motor is connected to the lead screw directly via a coupling.

Duty Cycle

$$\text{Duty cycle} = \frac{\text{on time}}{(\text{on time} + \text{off time})}$$

Example: 2,5 minutes on, 7,5 minutes off

$$\frac{2,5 \text{ min}}{(2,5 \text{ min} + 7,5 \text{ min})} = 25\% \text{ duty cycle}$$

The duty cycle is a function of the load and the ambient temperature. A higher ambient temperature and/or load will affect the duty cycle negatively, while a lower temperature and/or lower load will affect it positively. The duty cycles stated in this catalog are all valid for a 10-minute period.

Glossary

Dy – Lif

Dynamic Load Rating

The dynamic load rating (F_x) is the maximum load the actuator can move at a given speed. The relation between the dynamic load and the speed can be studied in the Load versus Speed diagrams. For some actuators, however, the column load limit will be exceeded if the extension tube extends beyond a certain point. Also see "Load Rating" "Forces" and "Column Load Limit".

Encoder

Encoders provide a digital output signal in the form of a square-shaped pulse train that can be used to determine the position of the extension tube. The encoder signal in a servo motor system is connected to the motion control so that it can control the servo drive and hence close the position feedback loop. The servo motors used on the precision linear actuators do not have an encoder. Instead, they incorporate a resolver feedback device that feeds a shaft-position signal to the drive control. The drive control also converts the resolver signal into a simulated encoder pulse train that can be used to feed a positioning controller. Also see "Resolver", "Servo Motor" and "Servo Drive".

End-of-Stroke Switches

We strongly recommend the use of switches at the ends of the actuator stroke to prevent the unit from running in to the mechanical end stops. Keep in mind that the extension tube will travel some distance (dependent of speed, load and actuator type) before it comes to a complete stop. This means the end-of-stroke switches must be placed before the mechanical end of stroke and will reduce the available stroke length.

Extension Tube

The extension tube slides in and out of the actuator's cover tube and is connected via the front adaptor to the load being moved or positioned. Also see "Cover Tube".

Extension Tube Side Load

The extension tube side loads (F_y and F_z) are the forces applied to the sides of the extension tube. The maximum allowed side loads can be found in the performance specifications for each actuator. The stated side loads are only valid for a completely retracted extension tube and will decrease as the extension tube extends. Also see "Forces".

Forces

The below figure (Fig. d) shows the definitions for the forces and moments used in this catalog. Always use these definitions in any communication with Thomson.

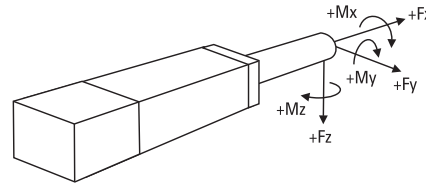

Fig. d

Frequency Inverter

A frequency inverter (also called frequency converter) is a type of motor drive that is used to control the speed, acceleration and deceleration of three-phase AC motors. A frequency inverter does that by changing the input frequency to the motor windings as the rotational speed of a three-phase AC motor is dependent on the frequency. Also see "Three-Phase AC Motor".

Inertia

Inertia is the property of an object to resist speed changes and is dependent on the shape and mass of the object. The inertia is important when sizing and selecting and also when tuning a servo system to optimum performance. Consult customer service for more information.

Inline Motor

An inline motor is mounted in line with the cover tube.

Installation Instructions

Each actuator has an installation manual to answer typical questions about mounting and wiring the actuators.

Lead Accuracy

Lead accuracy is a measure of how accurate the lead of a lead screw is. For a lead screw with a lead of 25 mm, the screw should, in theory, move the nut 25 mm per each revolution. In reality, there will be a deviation between the expected traveling distance and what is actually achieved. The deviation for a ball screw is typically 0,05 mm per 300 mm of stroke. Contact customer service for more information. Also see "Accuracy".

Lifetime Expectancy

The life-time expectancy is a function of many important factors, including load, speed, duty cycle, ambient temperature and screw type. To be able to accurately estimate the life-time expectancy, applications must be evaluated on a case-by-case basis. However, for most actuators, a travel life of at least 25 km under the maximum dynamic load can be used as a general approximation. Contact customer service for more information.

Glossary

Lin – Po

Linear Actuators

Actuators providing a linear thrust via an extension tube to lift, lower, push, pull or position a load.

Load Rating

There are many types of load ratings that need to be considered. Normally when you speak about the load, you refer to the load that the extension tube will pull or push, which is the dynamic load. But there may also be static, side, moment and column loads and forces from acceleration, deceleration, gravity and friction that are all equally important. Also see “Dynamic Load Rating”, “Static Load Rating”, “Side Loads”, “Column Load Limit”, “Tension and Compression Load”, “Acceleration” and “Deceleration”.

Magnetic Sensors

The magnetic sensors used in the precision linear actuators consist of a reed switch that are molded into a plastic housing. In the actuator, a magnet is mounted that travels back and forth with the extension tube. The magnet triggers the magnetic sensors, which are mounted on the outside of the cover tube. The sensors come in both normally open and normally closed versions.

Motion Control

A motion control is a control that is dedicated to control the motion of a servo motor. To be able to do this, the control must have inputs that can receive the feedback signal, which typically is an encoder signal (even if other devices such as potentiometers and resolvers, can be used) and an output which gives the motion commands to the servo drive. Motion controls can be stand-alone units or integrated in to other control systems. Also see “Control”, “Servo Motors and “Servo Drive”.

Motor Type

There are two types of electrical motors in different sizes used on the precision linear actuators; three phase AC motors and brushless AC servo motors. Also see “Brushless AC Servo Motor” and “Three-Phase AC motor”.

Mounting

The precision linear actuators can quickly and easily be mounted using any of the available mounting and adapter options. However, there are some things to consider when mounting the actuator. When using the clevis type of mounting, solid mounting pins should be used (avoid using roll- or spring-type mounting pins). The mounting pins (or trunnions) should be parallel to each other as shown below (Fig. e). It is also recommended to attach the load so that the force acts along the axis of the actuator (Fig. f). Any actuator using side-angel brackets, tapped holes or mounting feet should be mounted so that the cover tube or the extension tube does not bend or is subjected to bending forces during standstill or operation.

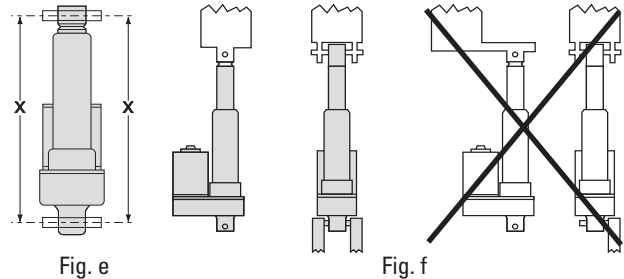

Mounting Options

To be able to mount a precision linear actuator, you must select the appropriate mounting and adapter options for your application. There are several different options to choose from and you can define your choice by using the ordering keys or part numbers. However, T and ECT actuators come with mounting holes and T-slots that can be used.

Operating and Storage Temperatures

The operating temperature is the range in which the actuator may be safely operated. All actuators can be stored or transported at the same temperature as the operating temperature. Contact customer support if the operating temperature will be exceeded during storage or transportation.

Parallel Motor

A parallel motor is mounted parallel to the cover tube.

Planetary Gear

A planetary gear is a gear system that consists of one or more outer gears (planet gears) rotating about a central (sun) gear. Typically, the planet gears are mounted on a movable arm or carrier, which itself may rotate relative to the sun gear. As a result, planetary gears have the input and output shafts in line with each other with rotation in the same direction. Planetary gears are robust, accurate and comparably small but are more expensive than belt or helical gears.

Positioning Accuracy

Positioning accuracy is the error between the expected and actual position and is the sum of all factors that will reduce the accuracy (i.e. repeatability, backlash, resolution, lead accuracy, and the accuracy of the motor, drive and motion control system). Some of these factors, such as backlash and lead accuracy, can sometimes be compensated for in the software of the motion control system being used. Also see “Accuracy”.

Glossary

Pr – Sta

Protection Class

The protection class refers to the environmental rating of the enclosure. The first digit applies to airborne contaminants, and the second digit to water/moisture.

IP65: dust tight and protected against low-pressure water jets from any direction.

Repeatability

Repeatability is the ability for a positioning system to return to a location when approaching from the same distance, at the same speed and deceleration rate. Some of the factors that affect the repeatability are the angular repeatability of the motor, drive and motion control system, system friction and changes in load, speed and deceleration.

Resolution

Resolution is the smallest move increment that the system can perform. Some of the factors that affect the resolution are the angular repeatability of the motor, drive and motion control system, system friction, the drive train reduction, the type and lead of the lead screw and changes in load, speed and deceleration.

Resolver

A resolver is basically a type of rotary electrical transformer used for measuring degrees of rotation and is commonly used on AC servo motors as a feedback device to control the commutation of the motor windings. The resolver is mounted to the end of a motor shaft and when the motor rotates, the resolver will transmit the position and direction of the rotor to the servo drive, which then can control the motor. Most servo drives for AC servo motors on the market today can convert the resolver signal in to a pulse train (encoder signal simulation), which can be used by a motion control to determine and control the position of the motor. Also see "Encoder", "Servo Drive", "Servo Motor" and "Motion Control".

RoHS Compliance

The RoHS directive stands for "the restriction of the use of certain hazardous substances in electrical and electronic equipment". This directive bans the placing on the EU market of new electrical and electronic equipment containing more than agreed levels of lead, cadmium, mercury, hexavalent chromium, polybrominated biphenyl (PBB) and polybrominated diphenyl ether (PBDE) flame retardants. All precision linear actuators, controls and accessories sold in the EU are RoHS compliant.

Service and Maintenance

Precision liner actuators only need to be lubricated. The interval between the lubrications depends on how frequent and hard the actuator works. The lubrication of the entire actuator is done at one single point. No other service or maintenance is required.

Servo Drive

A servo drive is an electrical device that controls the commutation of a servo motor. Different types of servo motors require different types of drives. To be able to run the system as a servo system, there must also be a motion control that gives the commands to the servo drive and some kind of feedback (encoder, potentiometer, etc) to the control so that it can determine and adjust the speed and the position of the motor (closed loop feedback). Some servo drives have built-in motion controls. Also see "Servo Motor", Brushless AC Servo Motor" and "Controls".

Servo Motor

A servo motor is a motor that works with a feedback device in a closed loop configuration controlled by a motion control. Any type of motor, can in principal work as a servo motor, but normally when speaking about servo motors you refer to motors that are specially designed to work in servo systems. Also see "Servo Drive", Brushless AC Servo Motor" and "Controls".

Side Loads

See "Extension Tube Side Loads".

Sizing and Selection

This catalog gives you an overview of what Thomson can offer you and an indication of which products may suit your applications. But in order to get the best solution, it is necessary to know your specific application requirements and to carry out detailed sizing and selection calculations. Please contact customer service for further help.

Speed Rating

The Speed versus Load diagrams on each product page show the maximum allowed speed at any given dynamic load, ranging from no load to maximum allowed dynamic load. For some actuators, however, the critical speed limit can be a limiting factor for the maximum allowed speed if the extension tube extends beyond a certain point. Also see "Load Rating" "Forces" and "Critical Speed Limit".

Static Load Rating

The static load rating is how much load the actuator will hold at standstill. This value can be higher than the dynamic load rating and depends on factors such as stroke length, column load rating, gear type, and maximum holding force of the motor brake. Consult customer service for more information. Also see "Load Rating".

Glossary

Str – Th

Stroke Length

The maximum stroke length for each actuator type can be found in the performance specifications. The stroke length is the available distance the extension tube can move from one mechanical end to the other. Keep in mind that extra stroke length above the application requirements will be needed to avoid hitting the mechanical end stops. We also recommend the use of end of stroke limit switches (both extension and retraction) to avoid running in to the mechanical ends by accident. Using end-of-stroke limit switches requires some deceleration distance to be added to the stroke so that the extension tube has time to stop before running in to the ends. Exactly how much extra stroke you need depends on many factors and needs to be determined for each application. Also see “End-of-Stroke Limit Switches”.

Tension and Compression Load

A tension load tries to stretch the actuator, and a compression load tries to compress the actuator (Fig. g). All precision linear actuators can manage the same tension and compression loads. Also see “Dynamic Load Rating”.

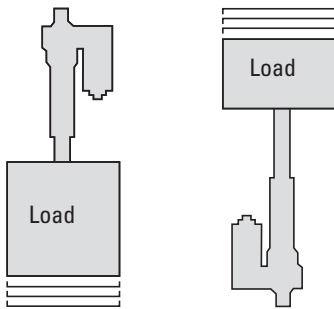

Fig. g

Three-Phase AC Motor

The three-phase AC motor is known under many names; squirrel cage motor, induction motor, asynchronous motor and asynchronous induction motor are a few. The three-phase AC motor can be run directly from a three-phase source, in which case its speed will be determined by the frequency and number of poles. The typical nominal speed of a 2-pole motor is around 2850 rpm, a 4-pole has half that speed and a 8-pole half of the 4-pole, etc. However, when running the motor directly from a three-phase source, there is no control of the speed, acceleration or deceleration. Instead, the motor accelerates as fast as it can, depending of the load, to its nominal speed. This puts stress on the mechanical components, if they can manage it at all. A precision linear unit with a three-phase AC motor is not designed to run directly from a three-phase source. Instead, a frequency inverter must be used that can control speed, acceleration and deceleration to keep these within the acceptable limits. A three-phase motor is relatively cheap, very robust and

needs no maintenance. The downside is that even though it can be controlled from a frequency inverter, it will never be as accurate as a servo motor system. Especially at low speeds (below approximately 10 Hz), the motor will start to lose torque and may also become overheated with time, as the internal fan mounted on the rotor will rotate too slow to be able to cool the motor sufficiently for operation. Using an external fan mounted to the back of the motor may solve this problem but is an added cost and will also make the installation larger. The speed at which overheating caution should be taken is marked in the “Speed vs. Load” diagrams with a dashed line instead of a continuous line (Fig. h). Also see “Frequency Inverter” and “Motor Type”.

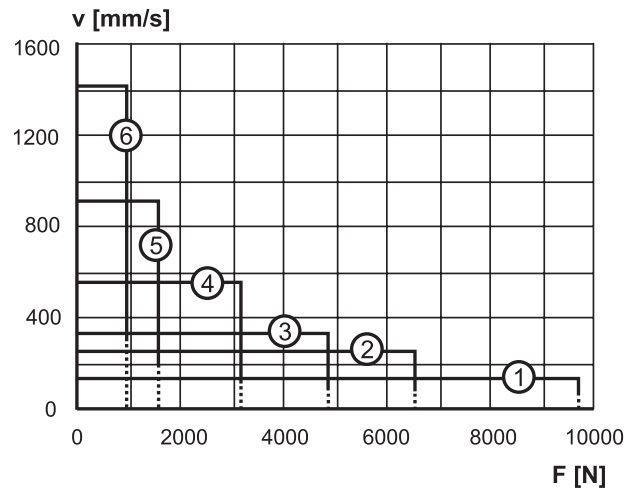

Fig. h

Application Data Form

Worksheet

Application Data Form*		
Submitted by:	Phone:	Date:
1. Company name	20. Do you need any special retracted length (cross hole c/c in mm)?	
2. Street address	21. What kind of motor would you prefer?	
3. City-state, zip	22. Is a holding brake required?	
4. Contact name	23. Do you need any of the optional features of the actuator?	
5. Phone	24. Do you need a matching drive to the actuator?	
6. Fax	25. What are the accuracy requirements of the application?	
7. E-mail	26. What are the environmental conditions (dusty, outdoors, wash down)?	
8. What is the estimated annual volume?	27. What is the operation temperature range in Celsius?	
9. What is the target price?	28. What is the duty cycle (on-time / on-time + off-time) in seconds?	
10. What is the current or alternative solution?	29. Do you need any certificates (UL, CE, etc.)?	
11. How much load is moved in Newton?	30. Do you require any print (dwg, dxf, faxed)?	
12. How much load do you need to hold in Newton?	31. Describe any additional requirements (packaging, labeling, etc.)	
13. How will the actuator be mounted (horizontal/vertical)?		
14. Is the load trying to stretch or/and compress the actuator?		
15. What speed do you want the actuator to move in mm/s?		
16. What is the life of the unit in cycles (one cycle = extend and retract)?		
17. What is the stroke length?		
18. How will the actuator be mounted to the extension tube?		
19. How will the actuator be mounted to the foundation?		

* Please enter all fields in the form and send it and any drawings to customer service by mail or fax. See the back of the catalog for the nearest location.

Contact us or any of our 2000+ global distribution partners by scanning the code below
or visiting www.thomsonlinear.com/contact



RegalRexnord™

www.regalrexnord.com

www.thomsonlinear.com

Precision_Linear_Actuators_CTUK-0003-08 | 20260330SK | MCC-12414-TL-EN-A4 03/26
Specifications are subject to change without notice. It is the responsibility of the product user to determine
the suitability of this product for a specific application. All trademarks property of their respective owners.
©2026 Thomson Industries, Inc. | 2400 Curtiss Street, Downers Grove, IL 60515 USA

THOMSON®